

atVision

Vision Software

User Manual MSO-VCU1-V1.6-US

Thank you for purchasing an Autonics product.

This user manual contains information about the product and its proper use, and should be kept in a place where it will be easy to access.

Autonics

Contents

Preface	7
Manual Guide	9
Common Symbols in the Manual	11
1. atVision	13
1.1. atVision Overview	13
1.2. atVision Workflow	14
1.2.1. Setup Mode	14
1.2.2. Mode of Operation	14
1.3. Install	16
1.3.1. System Requirements	16
1.3.2. Install The Software	16
1.3.3. Folder Configuration Information	17
1.3.4. Uninstall The Software	17
1.4. Connection	18
1.4.1. Network Settings	18
1.4.2. Device Connection	21
1.5. Screen Configuration	24
1.5.1. Ribbon Menu	25
1.5.2. Device Information	27
1.5.3. Image Viewer	28
1.5.4. Image List	29
1.5.5. Parameter	30
1.5.6. Work List	31
1.5.7. Inspection Result	33
1.6. Troubleshooting	34
1.6.1. Alarm Indication	34
1.6.2. Troubleshooting When Smart Camera Is Found Error	34
1.6.3. Causes of Error Display and Troubleshooting	35
1.7. Glossary of Terms	37
2. Basic Settings	41
2.1. Project Settings	41

2.2. Device Settings	41
2.2.1. Import/Export	41
2.2.2. Initialization	42
2.3. Image List Settings	43
2.3.1. Simulator	43
2.3.2. Filtering	43
2.4. Message Storage Settings	44
2.5. Login Settings	45
2.6. Firmware Update	46
2.7. Device/Software Details	48
2.7.1. Device Details	48
2.7.2. Software Details	48
2.8. Parameter Settings	49
2.8.1. Camera	49
2.8.2. Network	55
2.8.3. Input/Output	59
2.8.4. Advanced	78
3. Inspection	79
3.1. Shape and Detection Area	79
3.1.1. Shape	79
3.1.2. Detection Area	80
3.2. Default Setting	82
3.2.1. User Mode	82
3.2.2. Work List	83
3.2.3. Logic Combination Setting	87
3.2.4. Workgroup Manager	88
3.2.5. Inspection Results Settings	89
3.2.6. Automatic Inspection	91
3.3. Region of Interest Setting	92
3.3.1. Rectangle2D - Rectangle	92
3.3.2. Segment2D - Edge detection	93
3.3.3. Region - Multiple shapes	94
3.3.4. Segment Fitting Field - Line Segment Fitting Field	96
3.3.5. Path Fitting Field - Path	97

3.3.6. Circle Fitting Field - circle detection	99
3.4. Model Setup	100
3.4.1. Edge Model	100
3.4.2. Pixel Model	104
3.4.3. Geometry Model	107
3.4.4. Extraction Model	109
3.4.5. OCR Model	116
3.5. Inspection Items	121
3.5.1. Alignment	121
3.5.2. Identify	125
3.5.3. Measure	134
3.5.4. Matching	153
3.5.5. Pre-Processing	163
3.5.6. Data-Processing	176
4. Modbus List	187
4.1. Input	187
4.2. Output	196

Preface

Thank you for purchasing Autonics products.

Be sure to read and follow the **Safety Precautions** thoroughly before use.

This manual contains information about the product and how to use it properly, so keep it in a place where users can easily find it.

Manual Guide

- Use the product after fully reading the contents of the manual.
- The manual explains the product functions in detail and does not guarantee the contents other than the manual.
- Any or all of the manual may not be edited or copied without permission.
- The manual is not provided with the product.
- Download and use from our website (www.autonics.com).
- The contents of the manual are subject to change without prior notice according to the improvement of the product's performance, and upgrade notices are provided through our website.
- We put a lot of effort to make the contents of the manual a little easier and more accurate. Nevertheless, if you have any corrections or questions, please feel free to comment through our website.

Common Symbols in the Manual



Failure to follow instructions may result in serious injury or death.



Failure to follow instructions may result in injury or product damage.



Supplementary explanation of the function



Example of that function



Important information about the feature

1. atVision

1.1. atVision Overview

atVision is a dedicated software for the Smart Camera VC Series, and intuitive use is possible through the GUI (Graphical User Interface). In particular, it is possible to implement a flexible inspection environment by setting a total of 64 work groups as well as setting various parameters such as ROI range and input/output conditions.

In addition, real-time monitoring of the inspection results and additional correction through image filters if necessary improve convenience and accuracy of inspection.

Various inspection functions

Alignment, brightness, contrast, area, edge, shape comparison, length, angle, diameter, number of objects, barcode, OCR, pattern recognition, etc.

64 workgroup settings

Flexible response to changes in the working environment (32 inspection points for each group)

Manage workgroups and set parameters

Copies and saves workgroups saved between smart camera and PC

Implementation of flexible inspection environment by setting various parameters such as ROI range, input/output conditions, and image resolution

Real-time monitoring of inspection results

Real-time monitoring of pass/fail results of inspection items

Additional image correction through image filter, output data selection for each work group, and free Modbus TCP/IP address assignment

Inspection result image FTP server transfer

Inspection result images can be saved by sending them to an FTP server according to the settings, and file name creation rules can be set when saving for easy file management

1.2. atVision Workflow

1.2.1. Setup Mode

Network settings

- Device selection and connection
- Camera (image taking) settings
User ROI, subsampling, gain, trigger mode, trigger delay/interval/debounce, black level, exposure time, etc.

Network (FTP photo transfer) settings

Enabled or not, address, port, ID/password, path, file name, file type, etc.

Workgroup settings

- Takes a inspection target picture or open an image file
- Sets inspection items
- Additional settings (ROI by item, inspection parameters)
- Saves workgroups

Input/Output settings

- Input setting: External trigger edge setting
- Output settings: HS OUT 0 (Strobe output), HS OUT 1 / USER LED 0 / USER LED 1 (examination result related output), RS232 I/O, Modbus

Operation mode

- Switch to operation mode when automatic inspection starts

Manual inspection

- Manual inspection of shot images of workgroup items

1.2.2. Mode of Operation

Trigger

- Trigger input
- Trigger delay mode (time)



When the trigger passes, it moves to the CMOS image reading stage. When it fails, it returns to the initial stage of the operation mode.

Reads CMOS image

Taking an image picture using a picture element

Output

- Light (Strobe) output of HS OUT 0
- Result data output of HS OUT 1 (output logic combination, delay time and holding time can be applied)

Result output

- Transfers FTP image file
- Result data output via Modbus
- Transfers inspection results to atVision via Ethernet

Automatic inspection stop signal detection

When the automatic inspection stop signal is input, the inspection stops and changes to the setting mode

1.3. Install

1.3.1. System Requirements

The minimum requirements for using atVision are:

CPU	Intel i3 or higher or Ryzen 3 or higher
OS	Microsoft Windows 7 (×64) or later
RAM	6 GB or more
Storage space	10 GB or more of free hard disk space
Resolution	1280 × 800 or higher (recommended: 1920 × 1080)
Other	RJ45 Ethernet port, GigE network interface card



Additional hard disk capacity may be required depending on the quantity of inspection items.

This software is optimized for 1920 × 1080 resolution and 100% magnification.

It is recommended to use a GigE network interface card and a Giga Ethernet cable.

1.3.2. Install The Software

1. Download the atVision software from the Autonics website (www.autonics.com).
2. Close all programs before starting the installation. Double-click the installation file to start the installation.
3. When installing, read the entire license agreement agreement and click **I accept**.
You can view the entire license agreement agreement by scrolling the mouse, clicking the down arrow or pressing **Page Down** on your keyboard.
4. The default installation path is C:\Program Files (x86)\Autonics\atVision\
If you want to change the installation path, click **Browse**, specify the folder you want to install, and click **OK** to install it in that folder.
5. When the installation is complete, the Installation Complete screen appears. You can run atVision by double-clicking the atVision icon on the desktop.

1.3.3. Folder Configuration Information

Describes the configuration of the folder where atVision is installed.

During default installation, it is installed in [C:\Program Files (x86)\Autonics\], and if the installation location is changed, it is located in the changed installation folder.

When atVision installation is complete, atVision-related folders (Image, Log, Work) other than the atVision installation folder are created in the subfolder of [C:\Users\User Account\Documents\Autonics\], and workgroups and documents are saved.

Image

If 'Save Result Setting' is set, scan result image is saved in [C:\Users\user account\Documents\Autonics\Image\ResultImage] folder. The storage path is fixed and cannot be changed.

Log

Logs are saved for connection/disconnection with the device and inspection results.

Work

A folder for storing and managing workgroups registered by users. When saving or loading a workgroup, the folder is designated as the default path, and if the path is changed, it is saved in the changed folder.

1.3.4. Uninstall The Software

There are two ways to uninstall atVision: either by selecting menu:Start [All Programs > Autonics > atVision > Uninstall atVision] or by selecting atVision from the menu:Start [Control Panel > Uninstall a Program] menu.

If you execute uninstall program, a selection screen appears. Click **Yes (Y)** to remove it from the computer.

1.4. Connection

Smart camera uses TCP/IP (Transmission Control Protocol/Internet Protocol) to connect to atVision and send and receive messages and data.

Also, using FTP (File Transfer Protocol), the inspection result image is saved on the server and PC.

Data transmission/reception between smart camera and atVision uses asynchronous communication method, and smart camera uses server socket and atVision uses client socket.

1.4.1. Network Settings

Smart camera initial IP setting

Socket	IP Address	Subnet Mask	Gateway
Server	192.168.0.2	255.255.255.0	192.168.0.1

atVision initial IP settings

Socket	IP Address	Subnet Mask	Gateway
Server	192.168.0.3	255.255.255.0	192.168.0.1

1.4.1.1. Network Connection Settings

You can connect the device and atVision by changing the IP address of the device and PC.

Automatically Change Device IP Address

1. To check the IP address of the PC you are currently using, run menu:Start [Command Prompt] and enter 'ipconfig'. Check the 'IPv4 Address' when the Ethernet properties are displayed as follows.

```
Ethernet adapter :  
Connection-specific DNS Suffix . . . :  
Link-local IPv6 Address . . . . . : fe80::e982:35f4:95e7:86af%5  
Autoconfiguration IPv4 Address. . . : 169.254.134.175  
Subnet Mask . . . . . : 255.0.0.0  
Default Gateway . . . . . : 192.168.0.1
```

Command prompt

2. After adding the device to atVision, click **Edit** to open the 'Change Network' window.

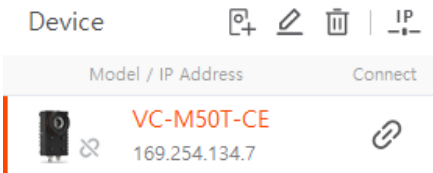

3. In the 'Change Network' window, check that the IP address of the device is configured with the same network band as the IP address of the PC, and then press **OK**.

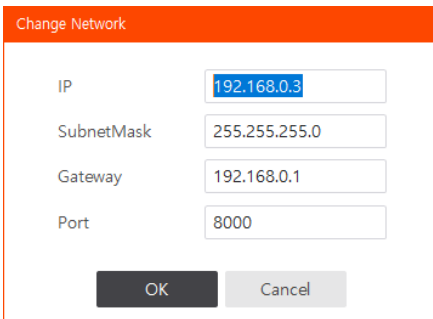

Change Network

4. When the change is completed, the completion notification window appears as follows.

Changes PC IP Manually

1. To change the IP of the PC, enter menu: Control Panel [Network and Sharing Center > Change adapter settings > Ethernet > Properties], select 'Internet Protocol Version 4 (TCP/IPv4)', and then click btn: [Properties(R)] Click.
2. In the 'Internet Protocol Version 4 (TCP/IPv4) Properties' window, select 'Use the following IP address (S):' and enter the IP address, subnet mask, and default gateway.
The following figure is an example of setting the IP change criteria according to the initial IP of the smart camera. (Smart camera initial IP address: 192.168.0.2)

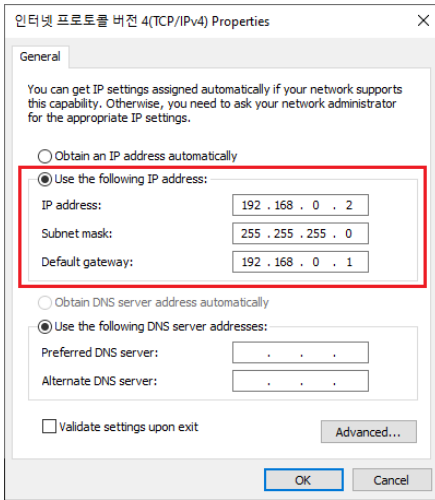

**Internet Protocol Version 4 (TCP/IPv4)
Properties Window**

3. Press **OK** to save the settings.



If the changed IP address is the same as the IP address being used for another PC or device, be aware that an IP conflict may cause network failure.

1.4.2. Device Connection

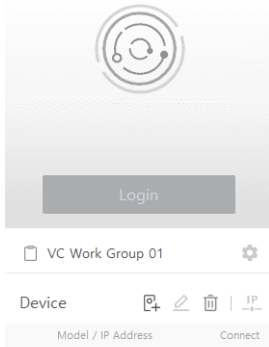

No device that can be connected.
Please add a device.

Initial status

1. Click the  button in the device information window on the left side of the program or **Device » Add Device** on the ribbon menu at the top of the program to open the 'Add Device' window.

2. Displays devices physically connected to the network of your PC.

After selecting a device, click **OK**.

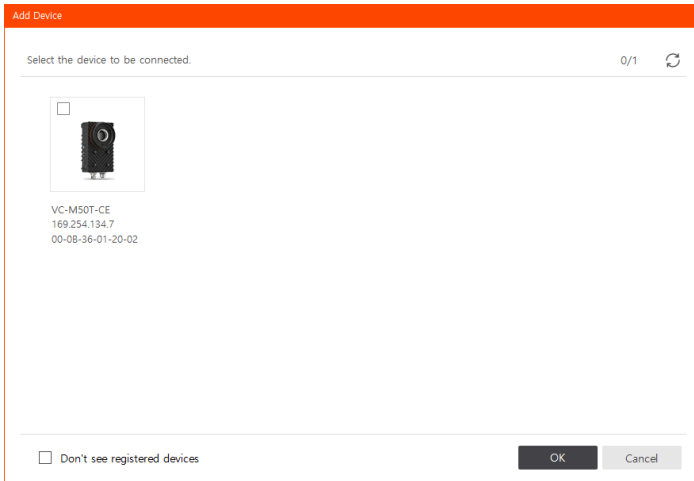

3. Devices that have been previously registered or are currently connected is displayed as disabled as follows:

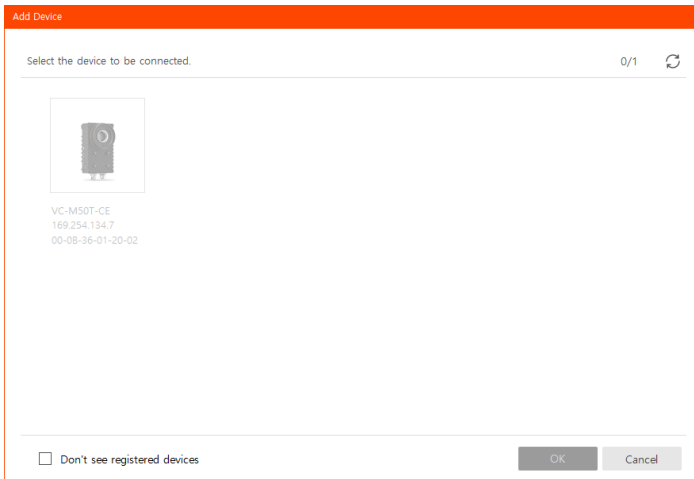

Connected device

4. When a device is added, additional items are displayed in the list at the bottom as follows.

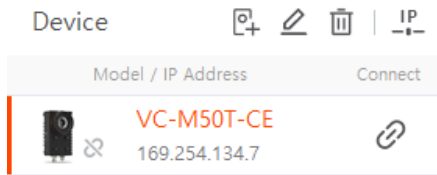

List of added devices



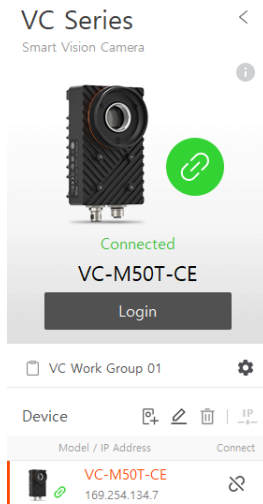

5. Double-click the added device in the device list or click the  button on the right to connect. 'Connected' is displayed as shown below and the connection is complete.



Connection completed



Display device connection status

-  : Not connected
-  : Connected
-  : Attempting to reconnect
-  : Scanning in progress

1.5. Screen Configuration

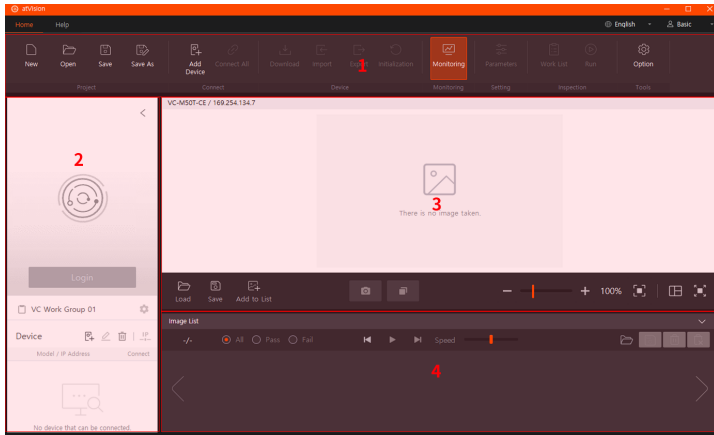

Program initial execution

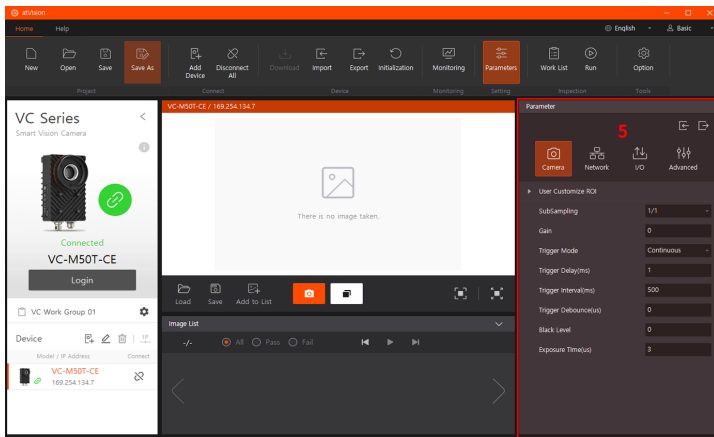





Device initial connection

- | | |
|------------------------------|---|
| 1. Ribbon menu | Shows the features of atVision. |
| 2. Device information | Displays device information. |
| 3. Image viewer | Displays the image of the connected device. |
| 4. Image list | Displays a list of images. |
| 5. Parameters | Displays parameter setting items. |



1.5.1. Ribbon Menu

Home





Project

-  New: Creates a new project.
-  Open: Opens the saved project.
-  Save: Saves the current project.
-  Save As: Saves the current project as.

Connection

-  Add Device: Creates a new project.
-  Connect/Disconnect All: Connects or disconnects all devices.

Device

-  Download: Applies parameter or work list changes to the device.
-  Import: Imports environment information from a file to the device. (parameter, work list)
-  Export: Exports the current environment information.
-  Initialization: Resets the current device information.



Monitoring

-  Monitoring: Checks the inspection results except the setting window.

Parameters

-  Parameter: Sets the parameter.

Inspection

-  Work list: Opens the scan edit window of the device. (registration, modification, deletion)
-  Run: Executes automatic device inspection.

Tools

-  Option: Sets save result setting and message saving method.

Help

Firmware Update

 Firmware Update: Manually updates the firmware.



Losing power while a firmware update is in progress can cause catastrophic problems with the device.

Software Information

 Software Information: Displays the current software information.

Help

 Help: Opens the user manual.

1.5.2. Device Information

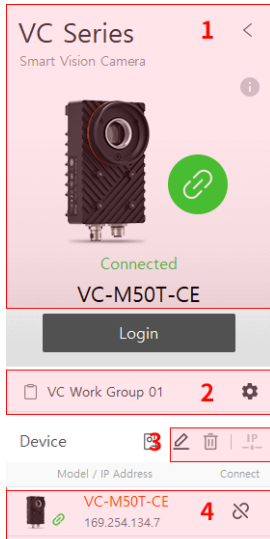

1. Device

Displays device related information such as connection status and model information.

2. Workgroups

Displays the activated workgroups.

3. Edit device list

Sets device addition, deletion, and network information change.

 : Adds device

 : Changes device name

 : Deletes the device

 : Changes network

4. Device list

Displays registered devices and sets device summary information and device connection/disconnection.







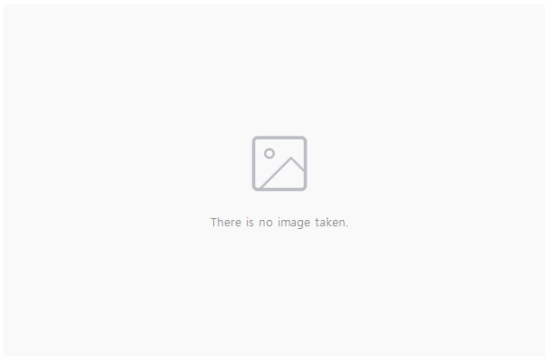

 : Connects the device

 : Disconnects the device

1.5.3. Image Viewer

VC-M50T-CE / 169.254.134.7



-  Load: Loads the image file to be displayed on the current screen.
-  Save: Saves the image file currently displayed on the screen.
-  Add to List: Adds the image currently displayed on the screen to the image list
-  Single Shot: Single shot
-  Continuous: Continuous shots
-  : Fits the image as window
-  : Fits the image in full screen
-  : Zooms in and out of the image
-  : Multi-view layout setting (up to 6 divisions)



@ Single shot,  continuous shots functions are available when menu:Parameter [Camera > Trigger Mode] is set to continuous mode.



- When setting the multi-view layout, you can monitor up to six devices' inspection at once. Select the device you want to display from the device list and drag and drop it to the desired location among the divided screens.
- You can switch to a single view using the Maximize button or to a multi-view with the return button.
When you close the window, the layout changes automatically.



- Frame drop may occur depending on the connection environment. It is recommend to use GigE network interface card and Giga Ethernet cable.
- The maximum frame rate is guaranteed only when the minimum exposure, inspection function is not set.
- When the mouse cursor moves over the image viewer, the coordinates and brightness value of the location are displayed.



X: X coordinate of the mouse cursor

Y: Y coordinate of the mouse cursor

Gray: Brightness value at the mouse cursor position

1.5.4. Image List

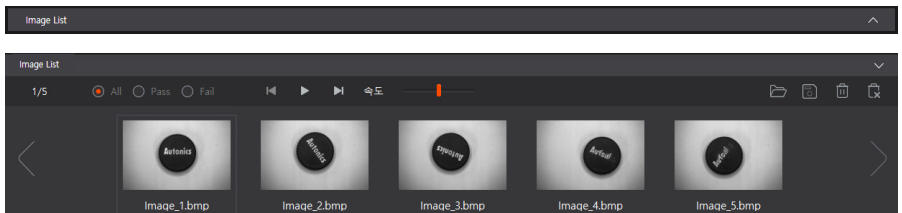

 : Opens image file in the image list

 : Saves the selected image

 : Deletes the selected image

 : Deletes all images

 : Displays image list window

 : Closes image list window



When you run atVision for the first time, you must click the ^ button to display the 'Image List' window.

1.5.5. Parameter

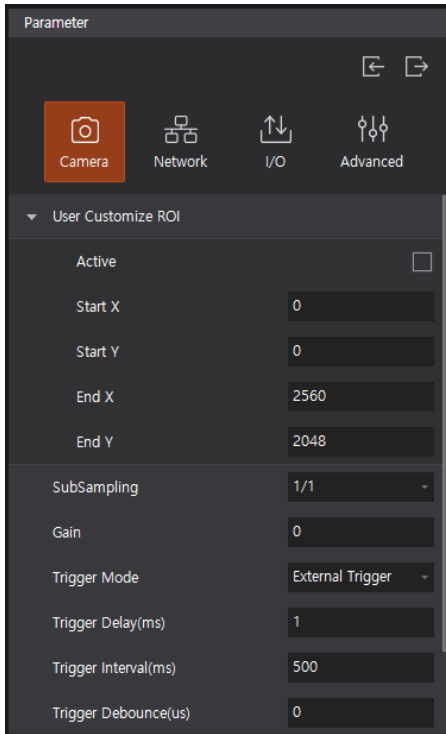

: Imports parameter setting file (file format: *.vpm)

: Exports to parameter setting file (file format: *.vpm)

Camera: Device optics settings

Network: FTP settings

I/O: I/O control settings related to automatic inspection

Advanced: Advanced device settings

1.5.6. Work List

Work List - VC Work Group 01

Logic All AND

01 02

Inspection

Time 0.00ms Volume 4.93KB / 240MB

01 Alignment

Image	Result
ROI	ROI
Edge Model	Detected Position
Edge Threshold	Similarity (%)
Similarity (%)	Center Point
	Alignment

02 Bar Code

Image	Result
Alignment	Fixed ROI
ROI	Detected Position
Barcode Format	Read Code
Base Bar Width	
Extraction Mode	
Edge Threshold	

Item Property

Filter by name

1. Alignment

Alignment

2. Identify

Bar Code

Data Matrix

QR Code

Extract Character

Read Character

3. Measure

Area

Angle

Brightness

Bar Code

Reads the 1D barcode

1. Logic combination

Displays and sets the logical combination formula result.

☰ : Sets the logical combination.

2. Manage data

Exports or imports the data file. (file format: *.vvp)

📁 : Imports inspection recipe file

📁 : Exports to inspection recipe file

3. Edit inspection items

Displays a summary of currently registered inspections. You can change the priority by changing the order of the work list by dragging and dropping the mouse after adding an item.



4. Inspection Editor

Edits registered inspections or perform manual inspections.

- ↻ : Initializes the work list
- 🗑️ : Deletes selected item
- 📄 : Re-arranges the work list
- 🔍 : Manually scans action

5. Toolbox, Properties

Displays a list of inspection tools and displays the properties of the selected inspection.

6. Description

Displays detailed properties of the selection.

1.5.7. Inspection Result

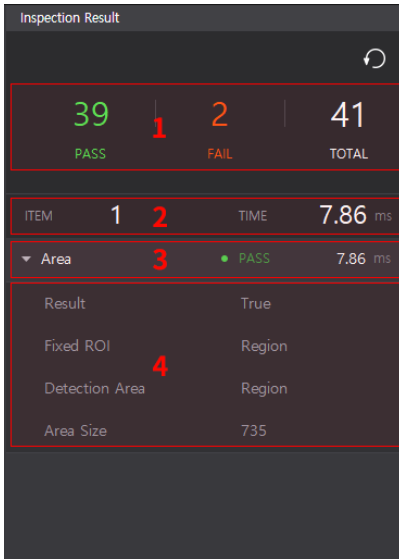

1. Inspection Result

Displays the number of inspections, pass and fail results.
You can reset the inspection quantity by pressing the {Reset} button.

2. Scan summary

Displays the total scan time.

3. Inspection result



Displays the time taken for each individual inspection.

4. Detailed inspection result

Displays detailed result of inspection item.

1.6. Troubleshooting

1.6.1. Alarm Indication

	Informative messages such as state changes
	A state that may damage existing data or cause system errors
	A state that causes system problems and the application cannot proceed

1.6.2. Troubleshooting When Smart Camera Is Found Error

If the POWER LED does not turn ON when the power is turned on

- Check that the power supply and power connectors are properly connected.
- Check that the power is being supplied correctly within the allowable range.
- Make sure the polarity of the power wiring is connected correctly.
- Check that there is no problem with the tightening of the power terminal block.

If it does not work due to the external input terminal error

- Check that the input COMMON and the wiring of each input terminal are connected correctly.
- Check that there is no problem with the operation of the input device.

If it does not work due to the external output stage error

- Check that the output wiring is connected correctly.
- Check if the power voltage connected to the output terminal is being supplied correctly within the allowable range.
- Check that there is no problem with the operation of the output device.
- Check that the load connected to the output terminal is within the rated range.

If Ethernet communication is not established

- Check that the LINK LED ON. If it is OFF, check the wiring.
- Make sure your communications (IP address, subnet mask, gateway) are set up correctly.
- Check that the wiring and specifications of the communication cable comply with our regulations.
- The cable must be provided by the manufacture's (sold separately).

1.6.3. Causes of Error Display and Troubleshooting

Error indication
Cause:
How to take action

ERROR_EMPTY_OUTPUT_DATA

A problem during the inspection did not produce a inspection result:

Check out the work list.

If there is a communication problem and the inspection result is 0 Byte:

Check the communication status.

ERROR_OVERFLOW_RESULT_BUFFER

The size of the inspection result value is too large:

Make the work list area of interest small.

ERROR_PIN_VISIBLE_BROKEN

Broken or missing Visible xml file in atVision installation folder:

Reinstall atVision.

ERROR_MACRO_EMPTY_IMAGE

No images to be used for inspection:

Check that the smart camera is taking images normally.

ERROR_LOAD_RECIPE

No the work list or corrupted file:

Regenerate the work list.

ERROR_LOGIC_NOT_INVALID

Disabled logical combination formula set:

Make sure it contains anything other than the logical combination formula AND, OR, NOT.

Unused check items are set:

Check for unnecessary inspection items.

ERROR_AVL_LICENSE_ERRORVL

Unlicensed or broken:

Contact your dealer.

ERROR_DESERIALIZE

Corrupted work list or inspection data file:
Regenerate the work list.
Rerun the automatic inspection.
Check the communication status.

ERROR_RECIPE_VERSION

Smart camera and atVision versions do not match:
Matche by updating the smart camera and atVision.

ERROR_LANGUAGE_VERSION

Multilingual file versions do not match:
Reinstall atVision.

ERROR_LANGUAGEFILE_BROKEN

Multilingual files are corrupted:
Reinstall atVision.

ERROR_EMPTY_FILTER

The work list is empty:
Check out the work list.

ERROR_WRONG_RECIPE_PATH

More than the work list file path:
Check the file path.
Save the work list again.

ERROR_NOT_EXIST_FILTER

The action you set for the logical combination does not actually exist:
Reset the logical combination.

ERROR_FILE_OPEN_FAIL

Broken the work list file:
Set up the work list file again.

ERROR_LOGIC

Invalid logical combination formula:
Reset the logical combination.

1.7. Glossary of Terms

OCR Model

It is a model that registers text and its shape and reads the text in the input text area.

Region of Interest (ROI)

You can specify a selectable inspection area of the image, which can reduce inspection time and amount of data.

Optical Character Verification (OCV)

Based on the font registered in the OCR model, the character is read and compared with the target character and the result value (Pass/Fail) is output.

Optical Character Recognition (OCR)

Reads characters for fonts registered in OCR model, or identifies non-registered characters.

Subsampling

This function takes some of the total values of rows and columns of an image.

Cell

It's the single smallest dot that makes up code.



Edge

This is the boundary line at which the brightness of the image changes from low value to high value or from high value to low value.

By extracting the edges, you can find the information you want to get from the image.

Image view of angle

This is the angle that expresses the range in which the subject is captured.

Binarization (Threshold)

Based on a specific threshold, it is divided into two zones, and values below the threshold are made black, and values above the threshold are made white.

Trigger

It is a term referring to the trigger of a gun, and in the VC series, it means a signal that causes a picture to be taken.

Pyramid

It is a set created by reducing the size of the input image by 1/2 step by step.

Pyramid level

It is a method of analyzing the image by gradually changing (reducing) the size. As the parameter size increases, the speed increases, but the accuracy decreases.

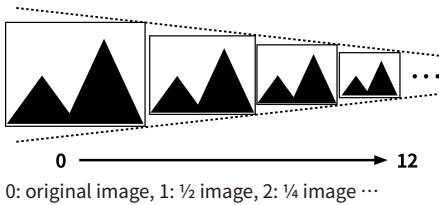

Edge hysteresis

Strong edge: A solid edge that falls within the edge threshold range.

Weak edge: An edge that is ambiguous to be judged as an edge.

A weak edge connected with a strong edge is judged as an edge, and as the hysteresis value increases, the edge is judged by extending the connection range to a farther edge.

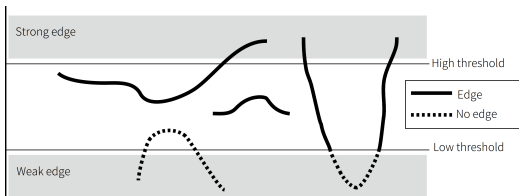

BMP

Windows Bitmap Image, bitmap digital picture file storage format

FTP (File Transfer Protocol)

File Transfer Protocol

JPG

Same as JPEG Joint Photographic Experts Group. Digital picture file storage format

Modbus RTU

Among Modbus transmission methods, Remote Terminal Unit transmission method

RS232

Serial communication (serial communication) standard interface

SNR (Signal to Noise Ratio)

The ratio of the signal magnitude to the noise signal magnitude at a given point in time.

2. Basic Settings

2.1. Project Settings

The project default file format is *.vpj .

If a device is registered in the device list when opening a new project file, it is checked whether the device is reset.

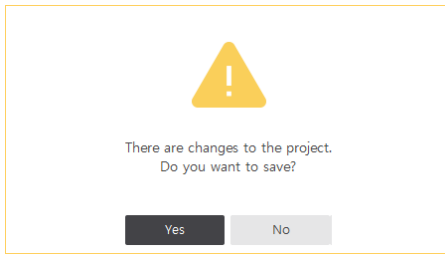

2.2. Device Settings

2.2.1. Import/Export

You can import or export the device information, including all parameter settings and inspection items, to a file.

The file is saved in *.vsf format.

2.2.2. Initialization

When you click **Device » Initialization** in the ribbon menu at the top of the program, the following warning window appears.

If you select OK, all settings and data of the set device is initialized.

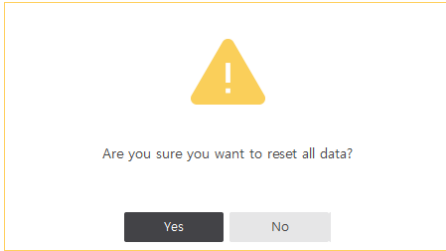

2.3. Image List Settings

2.3.1. Simulator

It is possible to adjust speed and control the image list.

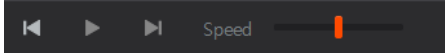

Click the play button to run the simulator.

The simulation speed is available to control by the right control bar.

When the simulation is complete, the images in the image list are judged and can be filtered.

2.3.2. Filtering

The image list supports filtering according to judgment after simulation.

All

Displays a list of all images.

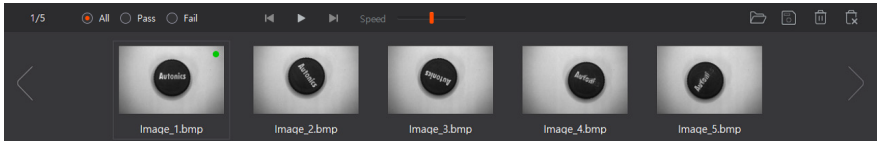

Pass

Displays only images that have passed according to the judgment.

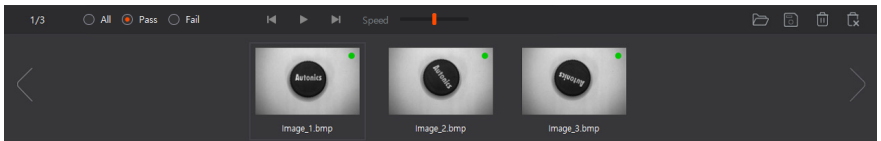

Fail

Displays only images that failed according to the judgment.

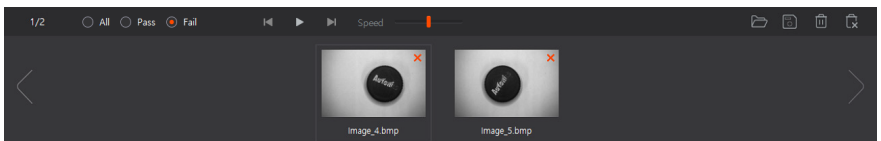

2.4. Message Storage Settings

When you click **Tools » Option** in the ribbon menu at the top of the program, the following setting window appears.

At Message menu, you can set whether to save messages generated by the software and set the storage path, and you can check the amount of storage space.

The default message storage path is "C:\Users\{username}\Documents\Autonics\atVision\Log".

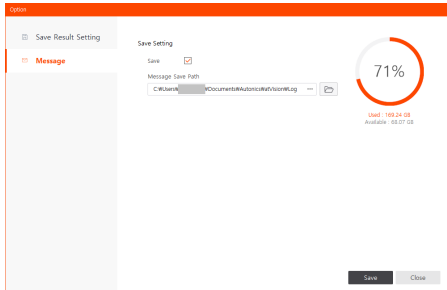

2.5. Login Settings

In accordance with Article 29, terminal device technology standard in Korea, it can be used only after logging in after connecting the device.

Click **Login** in the device information window on the left side of the program to log in. (Initial password: 0000)

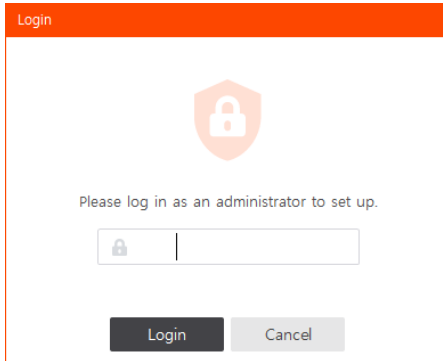

*Article 29, terminal device technical standard in Korea *

(Password for image information processing device, etc.) When connecting to a wired or wireless network for the first time, a video information processing device that has a function to view and transmit video information or control the device based on the Internet protocol cannot set or change the password and use it. It should have the ability to make it happen.

2.6. Firmware Update

You can proceed to update the device's firmware.

Update

1. Download the firmware from Autonics website (www.autonics.com) and unzip it.
2. After running atVision, click 'Help' - 'Update Firmware' on the ribbon menu at the top of the program to open an open window. Select the uncompressed firmware file (*.fwb) and click **OK**.
3. A warning window will open as shown below. After checking the contents, press **OK** to proceed with the update.

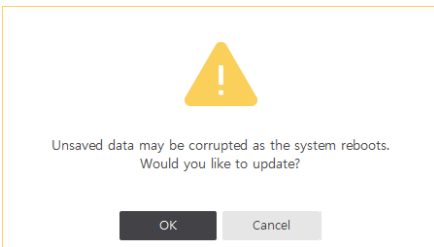

4. A progress display window appears and the firmware update proceeds.

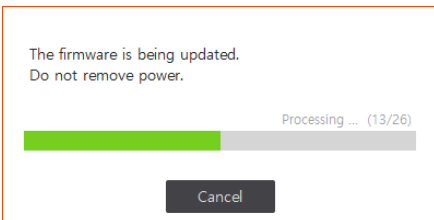

5. When the firmware update is completed normally, the following window appears.

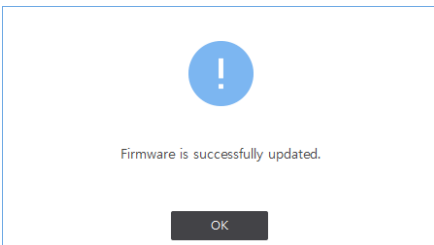



Turning OFF power while a firmware update is in progress can cause catastrophic problems with the device.

2.7. Device/Software Details

2.7.1. Device Details

You can check the device's status, address, version, and license ID.

If you click **i** in the device information window on the left side of the program, the device details window opens as follows.

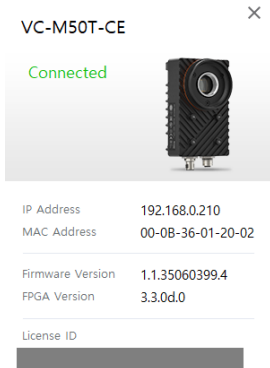

2.7.2. Software Details

You can check the software version.

If you click **Software Info** in menu:Help [Info] in the ribbon menu at the top of the program, the 'Software Information' window opens as follows.

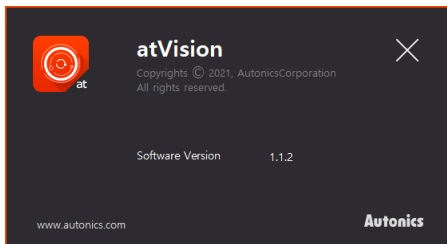

2.8. Parameter Settings

2.8.1. Camera

2.8.1.1. User Customize ROI

Specify the inspection area by setting the area of the desired pixel. Settings can speed up the scan.

Setting items

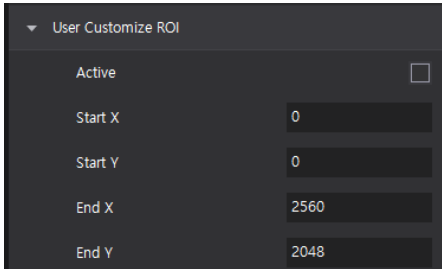

Item	Description
Active	Activates user ROI.
Start X	Enter the starting row (X) value.
Start Y	Enter the starting column (Y) value.
End X	Enter a value for the end of row (X).
End Y	Enter a value for the end column (Y).

Setting result

Source - Rows: 0 to 2560, Columns: 0 to 2048

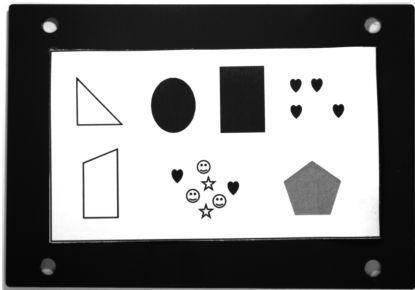

Set user ROI - Rows: 96 to 2400, Columns: 250 to 1800

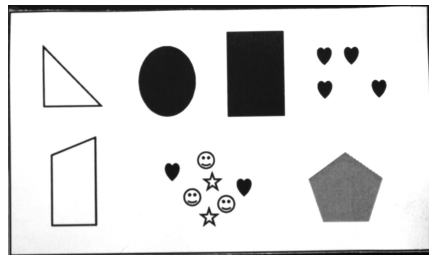

2.8.1.2. Subsampling

Scales the image in units of resolution to read pixels by skipping one column or row. This is available to speed up image capture without affecting the image's angle of view or SNR.

It is used when high baud rate with low resolution is required.



Setting result

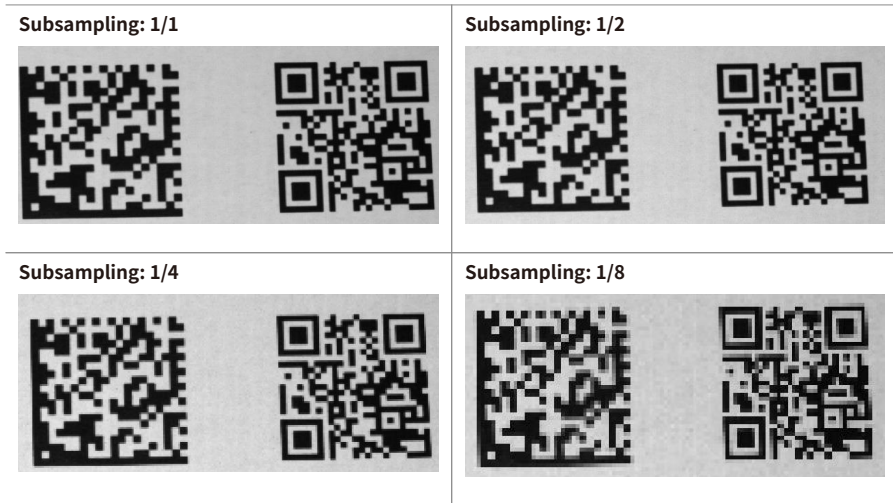

Do not set or change the subsampling settings before setting up the workgroup.
Depending on the settings of subsampling, some of the workgroup loading speed and ROI settings are changed.

2.8.1.3. Gain

It amplifies the input signal by an electrical method. The setting range is from 0 to 255.



Setting result

Gain: 0

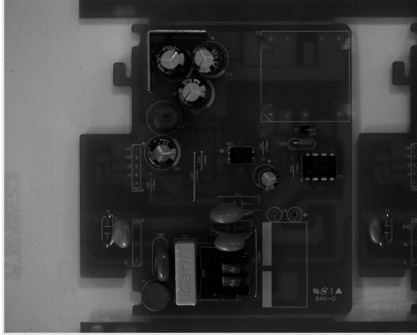

Gain: 255

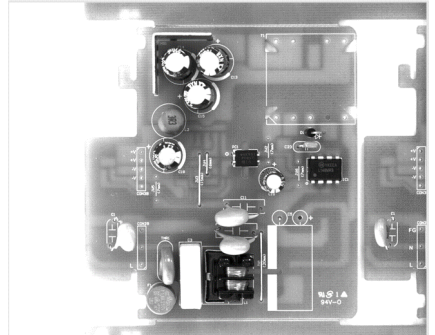

2.8.1.4. Trigger Mode

Set the image shooting method via trigger mode.



Item	Description
Continuous	Images are taken with a trigger that occurs inside the camera.
External Trigger	Images are taken with a trigger of an external input signal.
Manual	Images are taken with a trigger of the keyboard F5 key input.
Ethernet	Images are taken with a trigger of the transmission signal of Ethernet.
RS232	Images are taken with a trigger of the RS232 transmission signal.

2.8.1.5. Trigger Delay

When using external trigger mode, set the delay time from input of external trigger until the actual shooting starts.

The setting range is 0 to 10,000 ms.



Trigger delay action timing chart

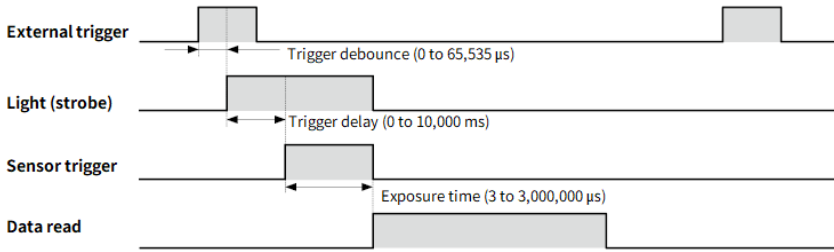

Trigger delay sequence

1. Applies the set trigger debounce time to the external trigger signal. (Trigger debounce time is adjustable)
2. After trigger debounce, trigger delay is applied.
3. When using an external light, the light turns ON.
4. Since the stabilization time varies depending on the lighting, the exposure of the image sensor starts after the trigger delay.
5. The image data is read at the end of the exposure.

2.8.1.6. Trigger Interval

When using continuous trigger mode, set the trigger interval time.

The setting range is 20 to 10,000 ms.



Trigger interval action timing chart

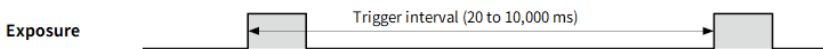

2.8.1.7. Trigger Debounce

Set the delay time for removing trigger input noise.

The setting range is 0 to 65,535 μ s.



2.8.1.8. Black Level

Set the highest limit for black signals in dark environments. The setting range is 0 to 255.



Setting result

Black level: 0

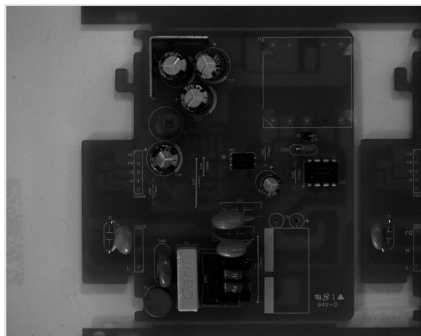

Black level: 255

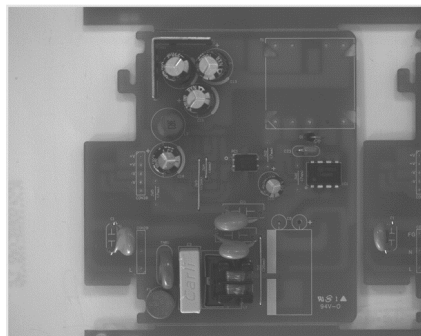

2.8.1.9. Exposure Time

Sets the amount of time the image sensor receives light.
The setting range is 3 to 3,000,000 μ s.



Setting result

Exposure time: 500

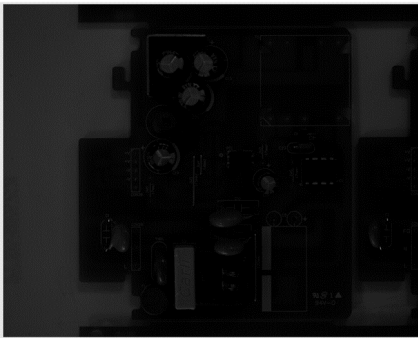

Exposure time: 1500

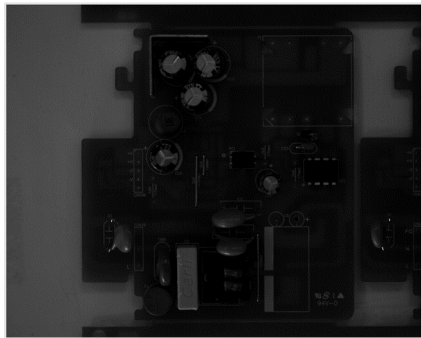

Exposure time: 5000

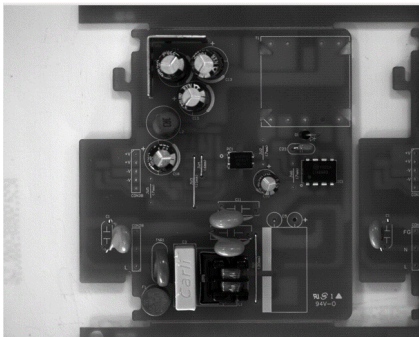

Exposure time: 10000

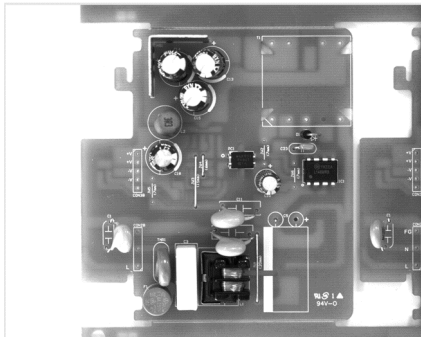

2.8.2. Network

2.8.2.1. FTP

The inspection result image stored in the memory of the smart camera is transferred to the FTP server. When activated, images and results captured during automatic inspection of the smart camera are sent to the FTP server.

To use the FTP client function, the FTP server must be on the same network.

▼ FTP

Active

Address 0.0.0.0

Port 0

ID

Password

Directory ...

Connection Test Execute

File Name

▶ Name Option

Save Option Fail

Draw Fail ROI

File Format BMP

Item	Description
Active	Activates FTP image file transfer.
Address / Port	Set the IP address and port of the FTP server.
ID / Password	Set the user ID and password.
Directory	Set the path on the server to save the image. When entering the path manually, use '\' ('\\') as the folder separator character, not '/'.
Connection Test	Tests the FTP connection and transfer using a dummy file.
File Name	Set the image file name.
Name Option	Set the image file name in detail. (disabled, image number, device name, inspection result, workgroup number, workgroup name, image capture time)
Save Option	Select an image to save. (Fail, Pass, All)
Draw Fail ROI	Marks and saves the user ROI area in the image that failed the inspection result.
File Format	Set the file format of the image to be saved. (*.bmp, *.jpg) JPG images are compressed images and have a smaller capacity than BMP images.



When the FTP client function is activated, the auto inspection time per one image may increase due to the transfer time.

Name Options

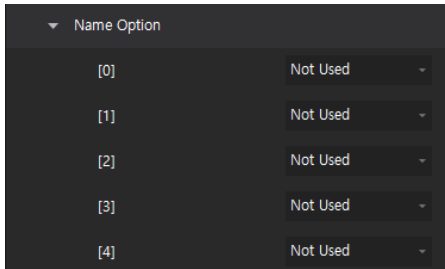

Item	Description
Image Number	The number of the image being inspected.
File Name	The name specified as a file name.
Inspection Results	Results of pass/fail.
WorkGroup Number	The number of the workgroup of the inspection.
WorkGroup Name	The name of the workgroup of the inspection.
ImageCapture Time	The time of image inspection.

Example of storage folder path and file name according to the setting

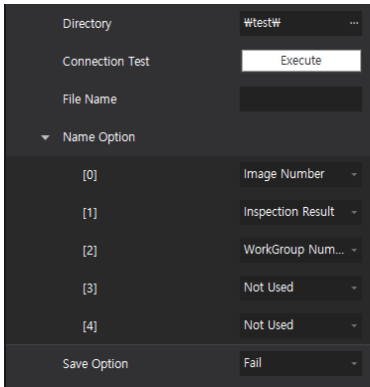

The screenshot shows a settings window with the following fields and options:

- Directory: #test#
- Connection Test: Execute
- File Name: (empty)
- Name Option (expanded):
 - [0]: Image Number
 - [1]: Inspection Result
 - [2]: WorkGroup Num...
 - [3]: Not Used
 - [4]: Not Used
- Save Option: Fail

Setting example

Save folder path C:\test

Filename 000008_Fail_VC Work Group 01.bmp
(image number_inspection result_workgroup name.file type)

2.8.3. Input/Output

2.8.3.1. Trigger

Acquires an input trigger by selecting either a rising edge or a falling edge.

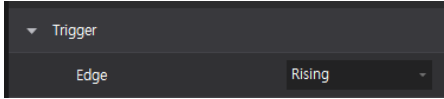

- Rising: The rising edge of the input trigger is input as an image capture signal.
- Falling: The falling edge of the input trigger is input as an image capture signal.

2.8.3.2. HS OUT0

It is used as an external light output signal, and is output as the light (strobe) of HS OUT 0 according to the trigger delay and exposure time settings.

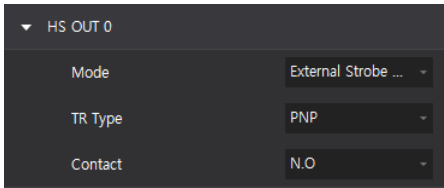

Item	Description
Mode	Sets the output mode. (Disable, External Strobe Out)
TR Type	Sets the control output. (PNP, NPN)
Contact	Sets the contact type. (N.O., N.C.)

HS OUT 0 operation timing diagram

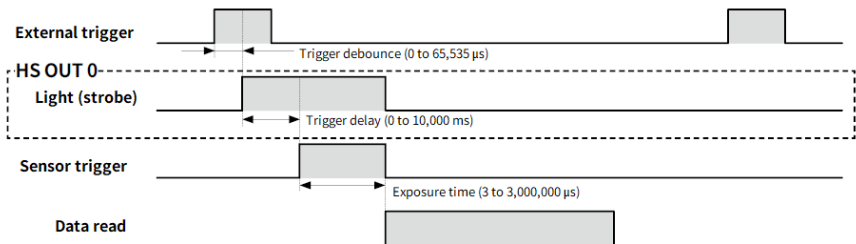

HS OUT 0 control output circuit diagram

PNP output

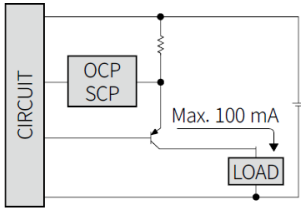

NPN output

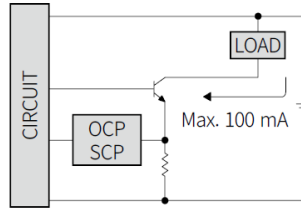

2.8.3.3. HS OUT 1

HS OUT 1	
Mode	Inspection Comp... ▾
TR Type	PNP ▾
Contact	N.O ▾
Delay Type	After Inspection ▾
Delay Time(ms)	0
Duration(ms)	10
Pulse Type	Pulse ▾

Mode

Sets the output mode.

Setting items

- Inspection Complete: Outputs at the time the inspection is completed regardless of the inspection result.
- Inspection Result Pass: Outputs only when the inspection result is passed.
- Inspection Result Fail: Outputs only when the test result is fail.
- Alarm: Notifies the user immediately when an alarm occurs by using a malfunction as an output signal
- Camera Work: Outputs image sensor operation status check during CMOS exposure and image data transfer time from the time of sensor trigger input

TR Type

Sets the control output. (PNP, NPN)

Contact

Sets the contact type. (N.O., N.C.)

Delay Type

Sets the applied output delay time after the trigger signal or after the completion of the inspection.

Delay Time

Sets the delay time until the time of output. The setting range is 0 to 65,535 ms.

Duration

Sets the output duration. The setting range is 1 to 65,535 ms.

Pulse Type

Sets the output pulse type.

Setting items

- Pulse: Output during the set output holding time
- Latch: Hold output until next output

Alarm

Sets the alarm to be output. (available to select multiple)

Setting items

- Trigger Input Error: Occurs when a trigger is input when the camera operation signal is High.
- Inspection Time Over: Occurs when the operation time of the registered work group exceeds the set inspection time.
- FTP Transfer Error: Occurs when there is an FTP connection failure or transmission error.

Timing diagram of after trigger signal

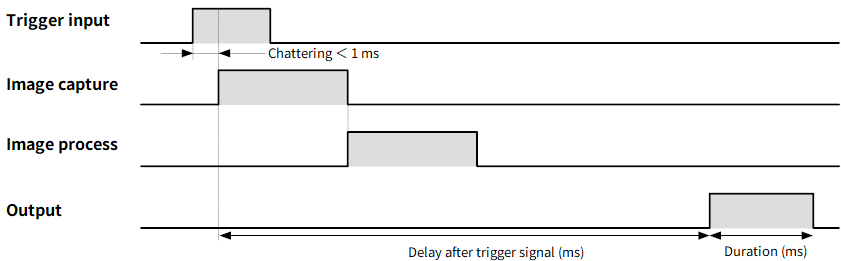

Timing diagram of delay time

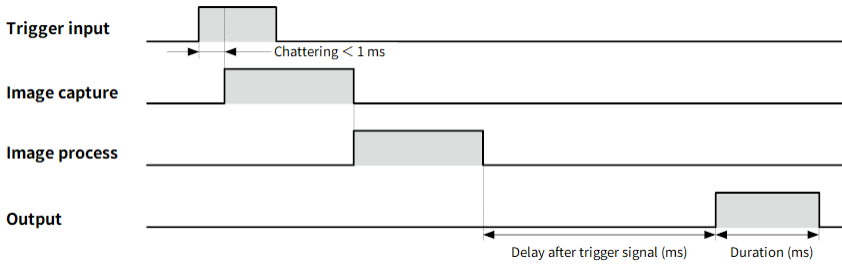

Timing diagram of duration

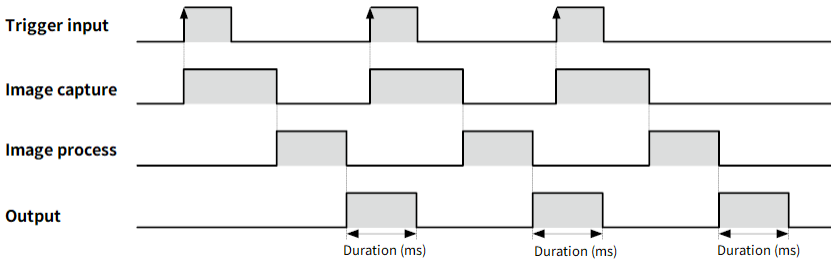

Timing diagram of camera work

Keeps the output high from the trigger input until the moment the image is saved to memory.

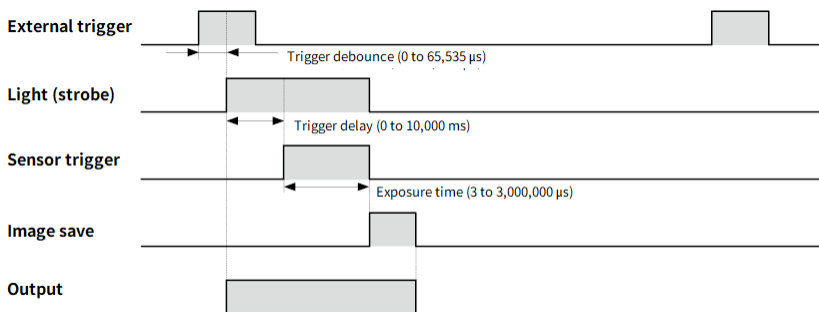

2.8.3.4. USER LED 1 / USER LED 2

Sets USER LED 1 and USER LED 2 located on the device status LED indicator.

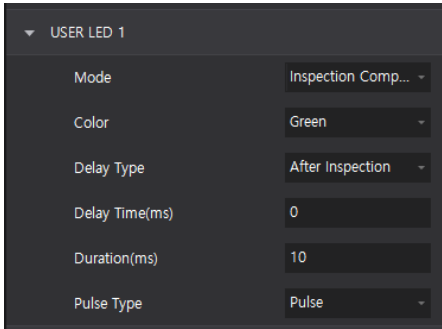

The image shows a configuration menu for 'USER LED 1'. The menu is dark-themed and contains the following settings:

Parameter	Value
Mode	Inspection Comp...
Color	Green
Delay Type	After Inspection
Delay Time(ms)	0
Duration(ms)	10
Pulse Type	Pulse

Mode

Sets the output mode.

Setting items

- Inspection Complete: Outputs at the time the inspection is completed regardless of the inspection result.
- Inspection Result Pass: Outputs only when the inspection result is passed.
- Inspection Result Fail: Outputs only when the test result is fail.
- Alarm: Notifies the user immediately when an alarm occurs by using a malfunction as an output signal
- Camera Work: Outputs image sensor operation status check during CMOS exposure and image data transfer time from the time of sensor trigger input

Color

Sets the color of the LED. (Green, Red)

Delay Type

Sets the applied output delay time after the trigger signal or after the completion of the inspection.

Delay Time

Sets the delay time until the time of output. The setting range is 0 to 65,535 ms.

Duration

Sets the output duration. The setting range is 1 to 65,535 ms.

Pulse Type

Set the output pulse type.

Setting items

- Pulse: Output during the set output holding time
- Latch: Hold output until next output

Alarm

Sets the alarm to be output. (available to select multiple)

Setting items

- Trigger Input Error: Occurs when a trigger is input when the camera operation signal is high.
- Inspection Time Over: Occurs when the operation time of the registered work group exceeds the set inspection time.
- FTP Transfer Error: Occurs when there is an FTP connection failure or transmission error.

2.8.3.5. RS232 I/O

RS232 (Modbus RTU) can be set.

If the output mode is Modbus and the output mode of 2.8.3.6, “Modbus” is RTU, Modbus parameter setting is possible.

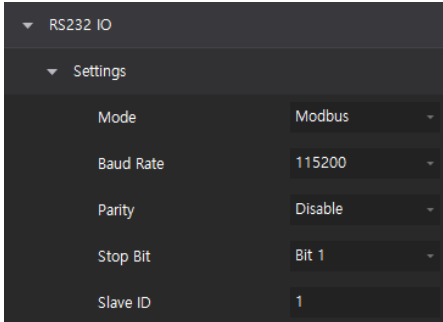

Item	Description
Mode	Sets the output mode. (Disable, Modbus)
Baud Rate	Sets the communication speed. (9600, 19200, 38400, 57600, 115200 bps)
Parity	Sets the communication parity bit. (Disable, Even, Odd)
Stop Bit	Sets the communication stop bit. (Bit 1, Bit 2)
Slave ID	Sets the smart camera ID.

2.8.3.6. Modbus

Sets Modbus related items.

VC operates based on the standard Modbus protocol in order to respond to various user environments. It does not support all internal controls, but provides functions such as 'change inspection item values during automatic inspection', 'check inspection result values', 'change workgroup' and 'trigger signal transmission' for user convenience.

The user can check and control the necessary parameters by adding them with Modbus, and there is no fixed mapping table.

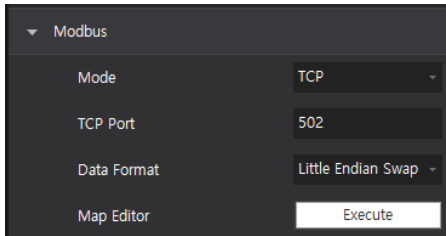

Item	Description
Mode	Sets the output mode. (Disable, TCP, RTU)
TCP Port	Sets the TCP communication port.
Data format	Sets the data format. (Little Endian, Big Endian, Little Endian Swap, Big Endian Swap)
Map Editor	Executes the map editor.

Data Format

For Float 123456.00 [REAL]
123456.00 = h 47 F1 20 00



- Big endian (A B C D): 47 F1 20 00
- Little endian (D C B A): 00 20 F1 47
- Big endian swap (B A D C): F1 47 00 20
- Little endian swap (C D A B): 20 00 47 F1



TCP port item is displayed only in TCP communication mode.

- Default port number: 502

Supported data types and sizes

The number base and classification notation in the items follows the form.

Hex	0x1234ABCD = h1234ABCD
Decimal	1234
Binary	10101011 ₍₂₎ = b10101011
Real	418 [REAL]
Integer	418 [DEC]

Boolean

- Data size: 1 bit
- Modbus mapping size: 1 word
- Example data: 0 [DEC] → h0000 / 1 [DEC] → h0001

Float

- Data size: 4 bytes
- Modbus mapping size: 2 word
- Example data
 - Little endian: 418 [REAL] → h0000D143 / 54.24 [REAL] → hC3F55842 / 546 [REAL] → h00800844
 - Big endian: 418 [REAL] → h43D10000 / 54.24 [REAL] → h4258F5C3 / 546 [REAL] → h44088000
 - Little endian swap: 418 [REAL] → h000043D1/54.24 [REAL] → hF5C34258 / 546 [REAL] → h80004408
 - Big endian swap: 418 [REAL] → hD1430000 / 54.24 [REAL] → h5842C3F5 / 546 [REAL] → h08440080

Integer

- Data size: 4 bytes
- Modbus mapping size: 2 word
- Example data
 - Little endian: 418 [DEC] → hA2010000 / 546 [DEC] → h22000000
 - Big endian: 418 [DEC] → h000001A2 / 546 [DEC] → h00000222
 - Little endian swap: 418 [DEC] → h01A20000 / 546 [DEC] → h02220000
 - Big endian swap: 418 [DEC] → h0000A201 / 546 [DEC] → h00002202

String

- Data size: 128 bytes
- Modbus mapping size: 64 word
- Example swap
 - ABC123 → h4241(BA), h3143(1C), h3332(32)



String of Modbus is based on ASCII Code.

Float conversion process (value: 54.24, data format: little endian swap, based on 32 bit)

1. Reorders incoming values according to endianness.

F5 C3 42 58 → 42 58 F5 C3

2. The sorted value (h4258F5C3) is expressed in binary.

h4258F5C3 → b 0100 0010 0101 1000 1111 0101 1100 0011

Binary structure (based on b 0100 0010 0101 1000 1111 0101 1100 0011)

◦ Sign: 0

▪ Sign calculation

0: positive, 1: negative

◦ Exponential part: 100 0010 0

▪ Calculation of exponents

$132 - 127 = 5$

◦ Mantissa part: 101 1000 1111 0101 1100 0011

▪ Calculate of mantissa

1. Adds 1 and a decimal point at the beginning of the mantissa to convert it as follows.

b1.10110001111010111000011

2. Multiplies the mantissa value by $2^{(\text{exponent})}$ and shifts the decimal point.

b1.10110001111010111000011 x $(2^5) =$

b110110.001111010111000011

3. To the left of the decimal point is an integer, and to the right is a decimal.

▪ Integer: b110110 → 54

▪ Decimal: b001111010011 → 0.24: $(1/8) + (1/16) + (1/32) + (1/64) + (1/256) + \dots$





Integer conversion process (value: 418, data format: little endian swap, 32 bit)

1. Reorders incoming values according to endianness.

01 A2 00 00 → 00 00 01 A2

2. It expresses h000001A2 as it is.

h000001A2 → 418

Available function codes

The supported functions are as follows.

Code	Function	Read/Write	Remarks
3 (03H)	Read Holding Registers	Read	Read the address
6 (06H)	Preset Single Register	Write	Single write to the address
16 (10H)	Preset Multiple Registers	Write	Continuous write of the address

Map Editor

VC's Modbus map is dependent on each work group, and each work group can have different sizes, addresses, setting values.

When deleting a work group, the Modbus map set in the group is also deleted.

Modbus map addresses are available from 0, and addresses must be assigned considering the size of the previous item.

Input

Modbus Setting

Input Output

Address	Name	Type	Size
0	Capture Trigger	Boolean	1
1	WorkGroup Change	Integer	2

OK Cancel

Output

Modbus Setting

Input Output

Address	Name	Type	Size
3	Bar Code[2] Result	Boolean	1
4	Bar Code[2] Read Code	String	64
68	Data Matrix[3] Fixed ROI X	Float	2

OK Cancel

Input

It is an item that can set the value with Modbus.

+ : Opens the add input window.

 : Deletes the selected item.

 : Initializes the entire list.

- Capture trigger: When the value 1 [DEC] is entered in the address, it acts as a trigger for automatic inspection.



Capture trigger function is available when menu: [Parameter > Camera > Trigger Mode] is set to 'Ethernet' when using Modbus TCP or 'RS232' when using Modbus RTU.

- Workgroup change: Displays the currently operating workgroup number during automatic inspection. If you enter a number in the address, automatic inspection is available by changing to the work group of the entered number.



- The work group corresponding to the entered number must be set and saved in VC in advance.
- If the Modbus map is not set in the changed work group, a Modbus error may occur or communication may be interrupted.

Modbus input items can change and check the values when 'automatic inspection' is in progress, and the values changed through Modbus are not saved.

If the X coordinate of the barcode ROI is set to 100.00 [DEC] in the atVision work list before inspection and it is changed to 200 [DEC] through Modbus during automatic inspection, 200.00 [DEC] is set until the inspection is stopped.

When the inspection is performed again, the stored work list value is applied and the inspection is performed with the X coordinate of the barcode ROI of 100.00 [DEC].



Output

It is an item that can only check the value with Modbus.

+: Opens the add output window.

: Deletes the selected item.

: Initializes the entire list.

- Inspection Complete: It is set to 0 [DEC] at the start of the inspection, and is set to 1 [DEC] when the inspection is complete.
- Inspection Pass: It is set to 0 [DEC] at the start of inspection. If the final inspection is pass, it is set to 1 [DEC].
- Inspection Fail: It is set to 0 [DEC] at the start of inspection. It is set to 1 [DEC] in case of final test fail.



If the inspection signal is input asynchronously and quickly, the values can be continuously set to zero. (Automatically set to 0 when the test starts)

- Alarm: Displays the alarm that can be set in HS OUT 1. You can know the alarm in bits.
 - 0th bit: Trigger input error
 - 2nd bit: Exceeded inspection time
 - 4th bit: FTP transfer error
- WorkGroup Change Check: When trying to change a workgroup, the change completion and errors are displayed as the following values.
 - 0 [DEC]: Changing
 - -1 [DEC]: Changing failed
 - The number of the workgroup to which the change was attempted: Change completed



4 [DEC]: Change completed (h0004)

To add input/output, click **+** to open the 'Add I/O' window, then double-click the name of the item to add or select it and click **OK**.

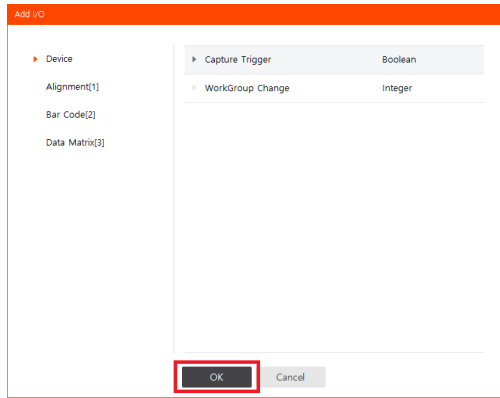

Items inside the list

Address

- Corresponds to Read Holding Register (4X).
- The address value of VC Modbus is based on decimal, and in an environment using hexadecimal, it must be converted to hexadecimal (17 → 0x11) before use. The protocol address value of Modbus follows the example below.



Address 00 = 40001 (0000)

Address 17 = 40018 (0012)

Address 50 = 40051 (0032)

- When adding input/output data, the address value is automatically set.
- You can change the automatically set address value to any value.
To manually change the address, click the address number, enter the desired number, and press the **ENTER** key. (Setting range: 0 to)

Name / Format / Size

Displays the name / format / size of the added input and output data. (Data size 1 = 16 bits)

- You cannot set the address value to be larger than the address value of the previous item.
- Addresses of input/output data cannot be duplicated.
- At minimum addition, each item is automatically set to the first allocatable address.
- Since the address 0 below Integer has a size of 2, the next item should assign the address to 2, not 1.

Modbus Setting

Input Output

Address	Name	Type	Size
0	Alignment[1] Detected Position.Y	Float	2
2	Bar Code[2] Fixed ROLX	Float	2
4	Bar Code[2] Fixed ROLY	Float	2

OK Cancel

- When saving workgroup copy, Modbus map is not copied or saved. For example, when saving workgroup 1 to workgroup 2, a new Modbus map corresponding to workgroup 2 must be created.
- Data format conversion (endian & data swap) function is only applied to 32 bit size (Integer, Float) data.
- Since the size of Modbus map may be different for each workgroup, the maximum size of Modbus varies depending on the workgroup.
- After editing (deleting, adding) only the inspection items in the same workgroup, not deleting the workgroup, the Modbus map must be set again.
- Since the address value of device items may change according to the change of work group, it is recommended to set the same address as much as possible.



To check all Modbus items, please refer to 4, Modbus List.

2.8.4. Advanced

2.8.4.1. Change Password

It is available to change the user login password. (Initial password: 0000)

Change Password Execute

Change Password

Current Password

New Password

New Password (Confirm)

OK Cancel

3. Inspection

3.1. Shape and Detection Area

3.1.1. Shape

3.1.1.1. Rectangle

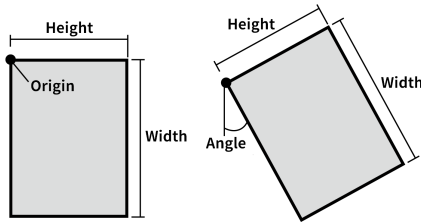

- Origin: Upper left position when setting
- Angle: Rotation angle counterclockwise from the origin
- Width: Width based on origin
- Height: Height based on origin

3.1.1.2. Circle

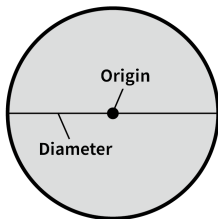

- Origin: Center of the circle
- Diameter: Diameter passing through the origin

3.1.2. Detection Area

3.1.2.1. Edge





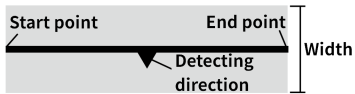

- Start point: Detection start point
- End point: Detection end point

3.1.2.2. Line Segment



- Start point: Detection start point
- End point: Detection end point
- Width: Inspection range

How to generate the detection direction of a linear region

Direction of detection	Generation method
 Top → Bottom	Creates when connecting lines by dragging from left to right
 Bottom → Top	Creates when connecting lines by dragging from right to left
 Left → Right	Creates when connecting lines by dragging from top to bottom
 Right → Left	Creates when connecting lines by dragging from the bottom to the top

3.1.2.3. Circle

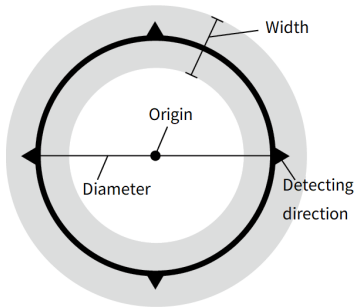

- Origin: Center of the circle
- Diameter: Diameter passing through the origin
- Width: Inspection range

Detection direction and range of circular area

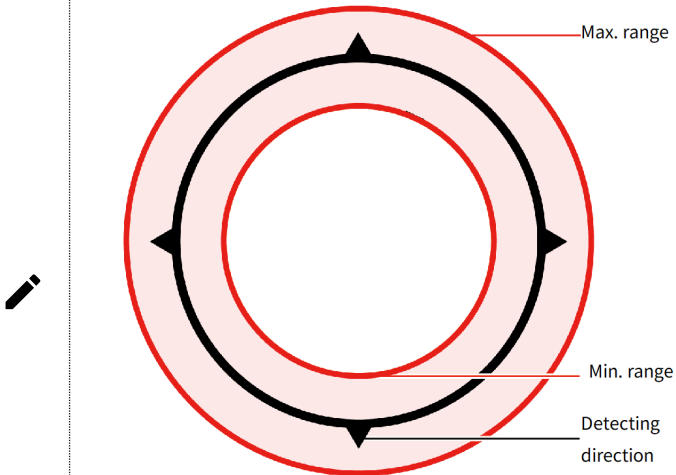

- Maximum range: The maximum size of the circle to be detected.
- Minimum range: The minimum size of the circle to be detected.
- Detecting direction: Searches the circle in the direction it is pointing.

3.2. Default Setting

3.2.1. User Mode

When atVision is initially launched, it is set to the basic mode and can be changed to Expert Mode by clicking **Basic** in the tab menu at the top right of the program.

Basic mode

For easy setup - displays some parameters

01 Normalize Image	
Image	Result Image
ROI	
New Min Brightness	
New Max Brightness	

Expert mode

For advanced settings - displays full parameter

01 Normalize Image	
Image	Result Image
ROI	
New Min Brightness	
New Max Brightness	
Brightest Adjustment	
Darkest Adjustment	

3.2.2. Work List

Up to 32 inspection items can be registered, and inspection item editing and logical combination settings are possible.

The maximum storage capacity per work list is 240 MB.

3.2.2.1. Add

To set up the work list, select and add inspection items from the item tab on the right side of the screen.

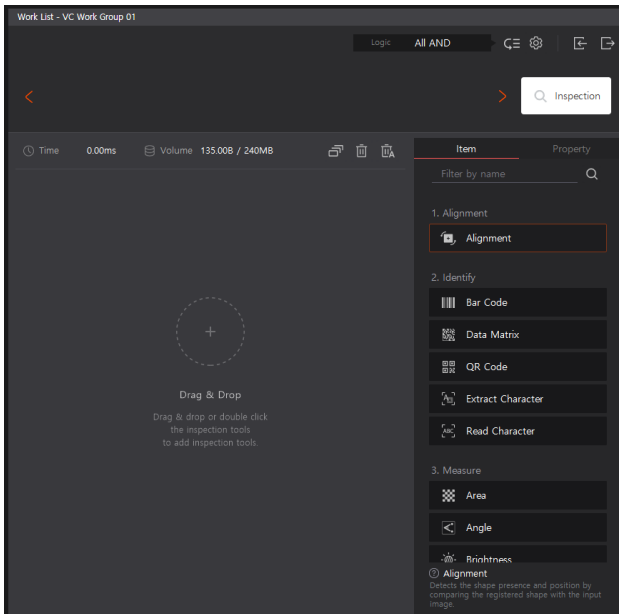

3.2.2.2. Settings

1. Drag and drop an inspection item from the item tab on the right to the inspection area or double-click to add it to the inspection editor. You can search for inspection items using the search bar at the top of the item tab.

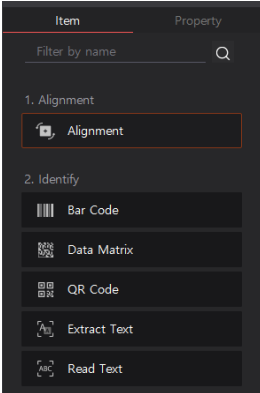

2. When each inspection item is selected in the inspection editor, the item tab on the right is converted to the property tab.

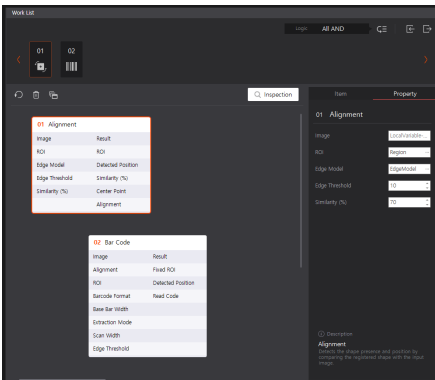

3. In the Property tab, complete the property settings for each inspection item.

Item	Property
01 Alignment	
Image	LocalVariable...
ROI	Region ---
Edge Model	EdgeModel ---
Edge Threshold	10 ▾
Similarity (%)	70 ▾

 Description

Alignment
Detects the shape presence and position by comparing the registered shape with the input image.

4. When connecting the output of an inspection item to the input of another inspection item, place the mouse on the right side of the output item and drag the displayed button to connect it to the input item.

You can unlink and relink to another item of the same type by right-dragging the linked check item button again.

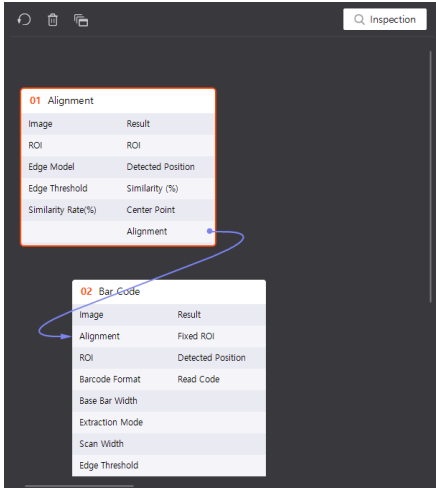

3.2.3. Logic Combination Setting

You can set up a logical combination for the inspection results.

You can open the logical combination setting window by clicking the \mathbb{E} button in the work list window.

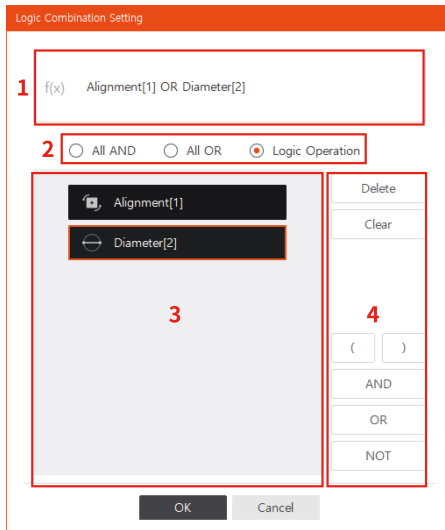

1. Logical combination

Displays logical combination formulas.

2. Logic operation setting

Set the logic for inspection items.

- All AND: Outputs the result of all inspection items by AND operation
- All OR: Outputs the result of all inspection items by OR operation
- Logic operation: The user specifies a logical combination for each inspection item and outputs (AND, OR, NOT)

3. Inspection items

Displays the currently registered inspection items.

4. Formula settings

A tool for creating logical combination formulas.

3.2.4. Workgroup Manager

You can manage up to 64 workgroups, and you can set the device's workgroup save and load settings. When you click '⚙️' at the top of the worklist, the following window appears.

If the right toggle button is activated, the corresponding work group is automatically set after power is applied.

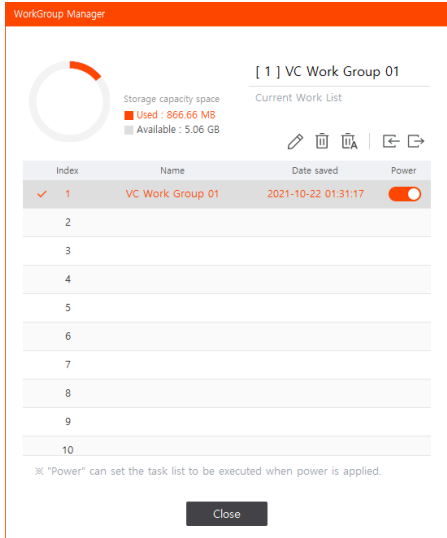

- ✎ : Edits the workgroup name.
- 🗑 : Deletes the selected workgroup.
- 🗑 : Deletes all workgroups stored in the workgroup manager.
- 📁 : Imports the selected workgroup.
- 📁 : Saves the current work list to the selected work group.

3.2.5. Inspection Results Settings

When you click **Tools » Option** in the ribbon menu at the top of the program, the following window appears.

At Save Result Setting menu, it is available to set.

If 'Auto Save' is selected, 'Image Save Setting' and 'Folder Saving Setting' at the bottom are activated and detailed settings are displayed.

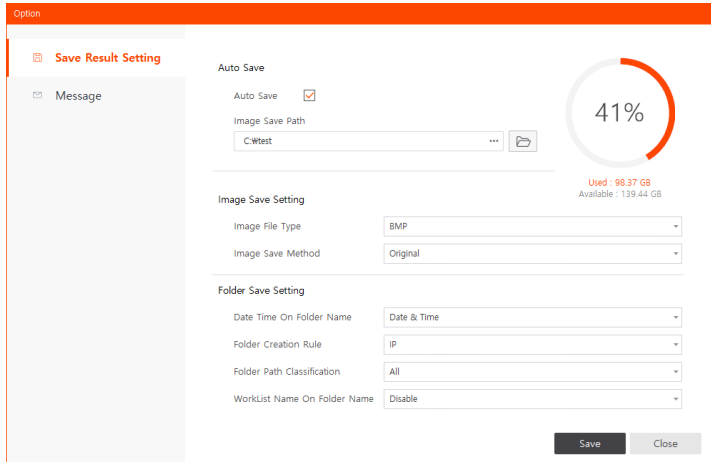

Image File Format

Set the file format of the scan result image to be saved. (BMP, JPG)

Image Save Method

Select the image you want to save.

- Original: Saves the original image taken.
- Import Result: Saves the image with the test results displayed.
- Original+Result: Saves both the original image and the image displayed as the inspection result.

Date Time On Folder Name

Creates a folder by date and time.

- None: Not creates a folder by date and time
- Date: Creates a folder by date.
- Date & Time: Creates a folder by date and time.

Folder Creation Rule

Set the name of the folder to be created.

- IP: Creates a folder with the device IP address as the folder name.
- MAC: Creates a folder with the device MAC address as the folder name.
- IP+MAC: Creates a folder with the 'IP address_MAC address' of the device as the folder name.

Folder path Classification

Set the inspection image to be saved.

- All: Saves all images regardless of test result pass/fail.
- Only Fail: Saves only images that failed inspection results.

WorkList Name on Folder Name

When select the 'Enable', Creates a subfolder with the workgroup name.



Device IP address: 192.168.0.2

Workgroup name: Workgroup_Test

Folder creation rule: IP

Inspection List Name on Folder Name: Enable

Result: Creates a Workgroup_Test folder in the 192.168.0.2 folder and saves the images.

3.2.6. Automatic Inspection

Click the 'Run' button on the ribbon menu at the top of the program to automatically perform the inspection registered in the work list.

You can check the inspection result in real time through the inspection result tab on the right side of the program, and click the arrow to select each test item.

You can check the detailed results.

At the end of the inspection, press the 'Stop' button to end the test.

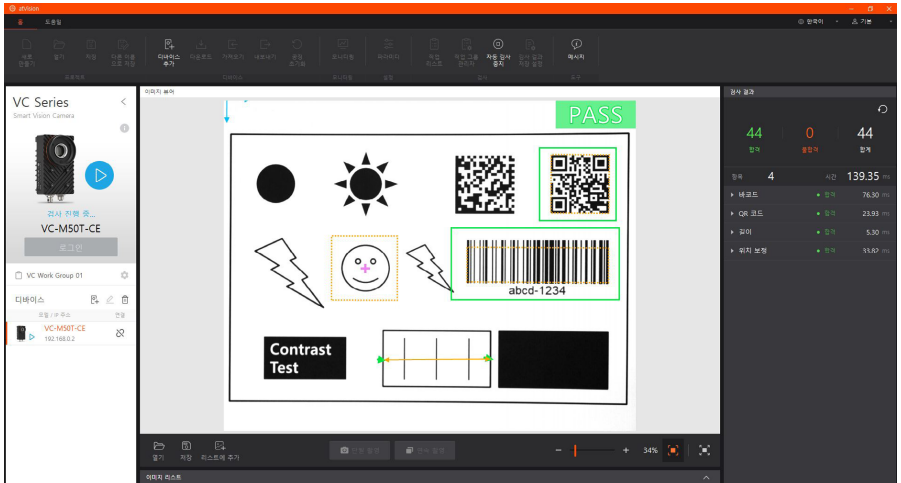

3.3. Region of Interest Setting

After adding the inspection items, click the  button to the right of the region of interest in the Property tab.

When the setting window appears, set the area of interest using the drawing tool on the left.

3.3.1. Rectangle2D - Rectangle

Set up a rectangular area of ROI.

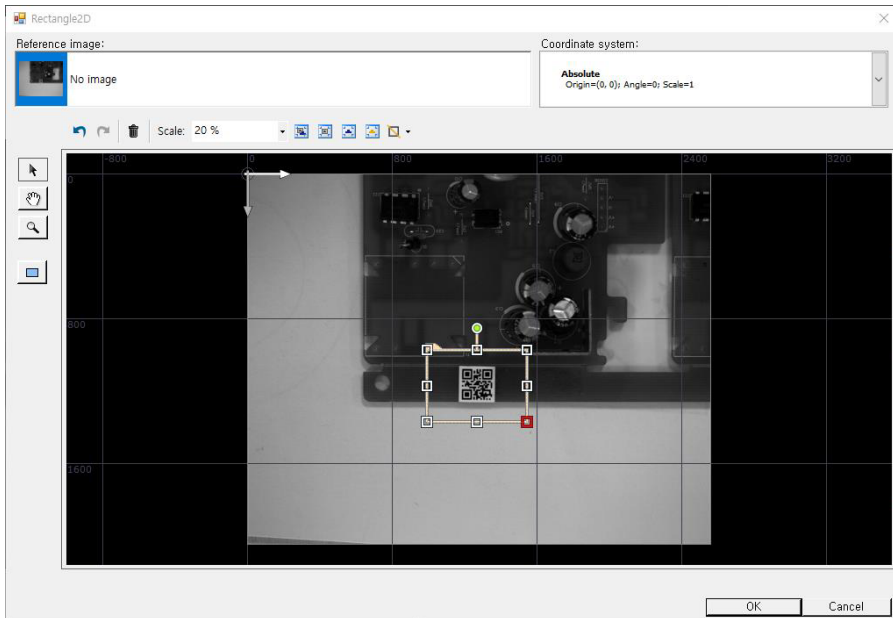

Setup method

1. Select a point to set as a region of interest.
2. Drag the mouse to the desired size.
3. After completing the settings, click the **OK** button.

3.3.2. Segment2D - Edge detection

Set the region of interest to detect edges.

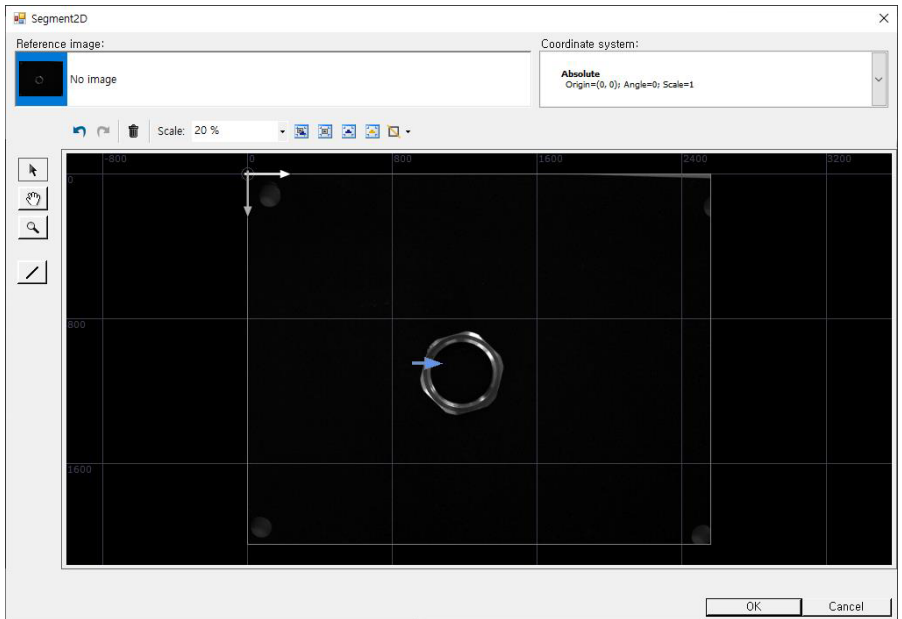

Setup method

1. Drag the mouse from the desired position (start point) to the desired position (end point).
2. After completing the settings, click the **OK** button.

3.3.3. Region - Multiple shapes

Set the region of interest for a shape that combines multiple shapes.

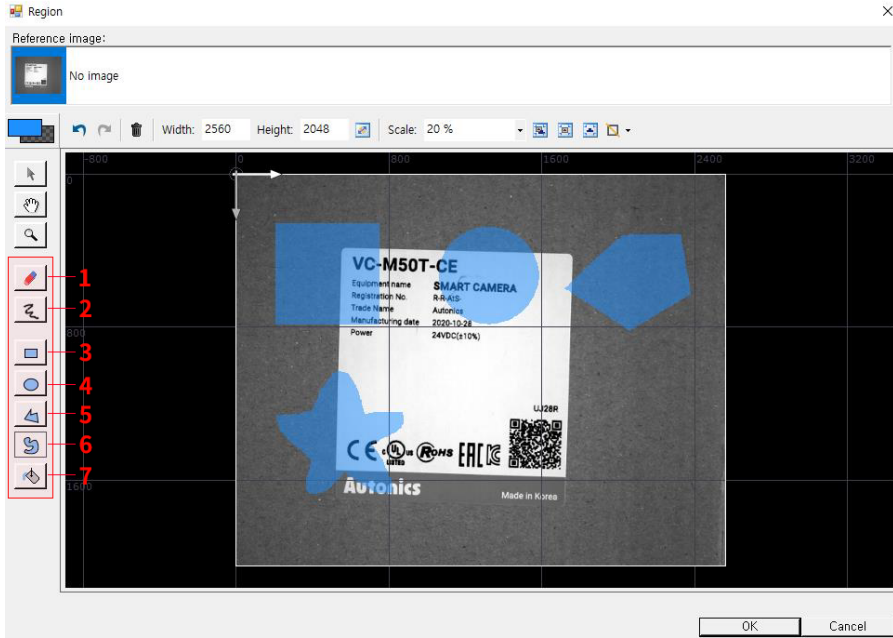

Number	Name	Function
1	Eraser	Erases setting area
2	Brush	Draws brush area
3	Rectangle Region	Draws a rectangle region
4	Elliptical Region	Draws an elliptical type region
5	Polygon Region	Draws polygon region
6	Free-Hand Region	Draws a free region
7	Fills Region Hole	Fills in the hole in the setting area

Setup method

1. Select the tool you want to use from the left panel.
2. Set the region of interest in the desired shape.
3. After completing the settings, click the **OK** button.



Once set, the area cannot be selected or moved. Reset after removal using the eraser tool.

3.3.4. Segment Fitting Field - Line Segment Fitting Field

Set the region of interest to detect line segments.

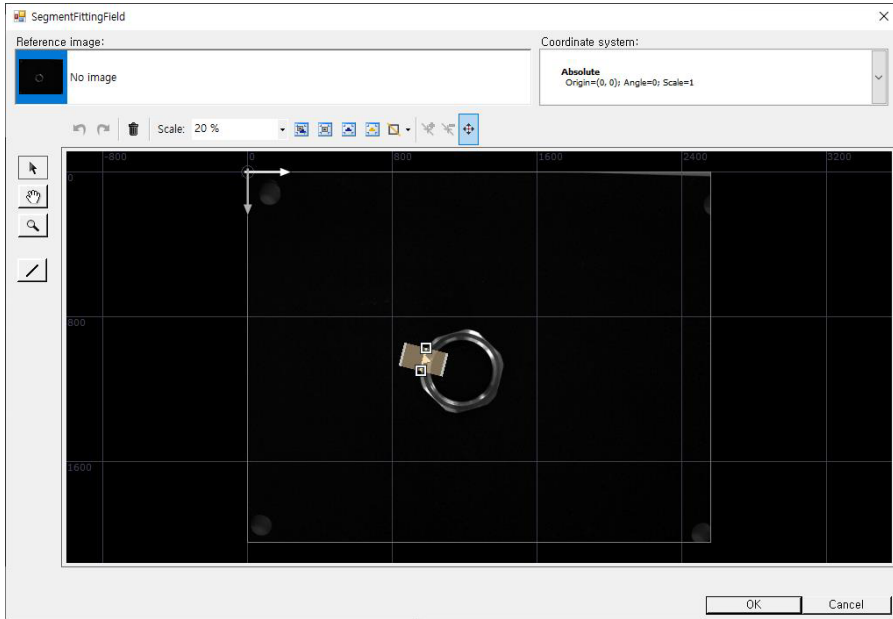

Setup method

1. Drag from the desired position (start point) to the desired position (end point).
2. Move the cursor to adjust the detection range and click to set.
3. After completing the settings, click the **OK** button.

3.3.5. Path Fitting Field - Path

Set up a region of interest in the form of a path to detect multiple edges.

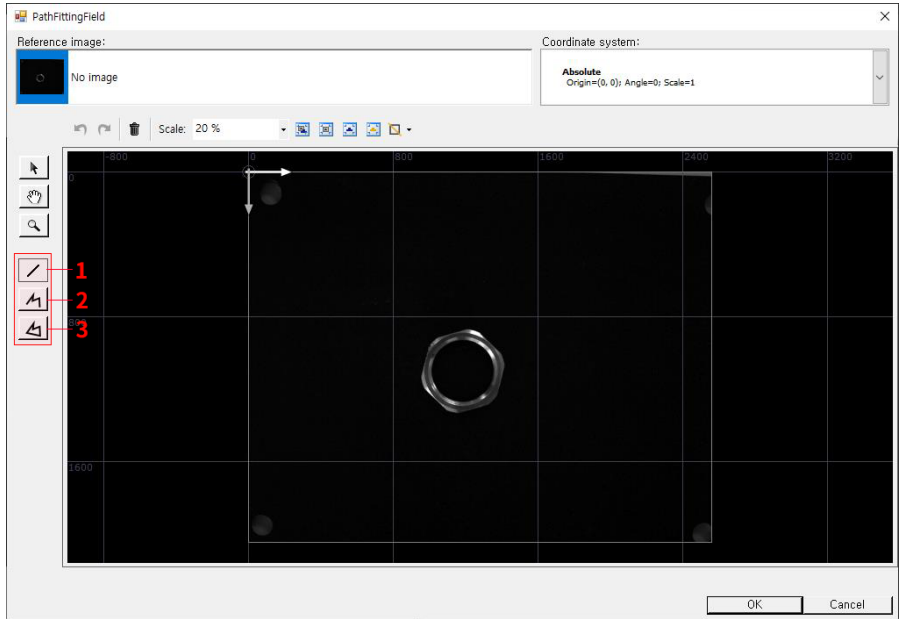

1: Creates a new 2-point path

Creates a path with two points.

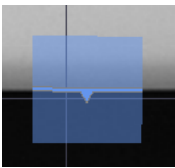

Setup method

1. Drag the mouse from one point to the desired location and click.
2. Move the cursor to adjust the detection range and click to set.

2: Creates a new opened path

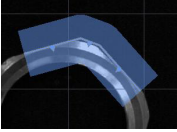

Setup method

1. Drag the mouse from one point in the desired direction.
2. Click at the point to change the direction of the path.
3. Double-click the left mouse button at the last point of the route to complete the route setup.
4. Move the cursor to adjust the detection range and click to set.

3: Creates a new closed path

Creates a closed path.

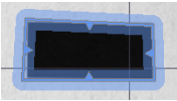

Setup method

1. Drag the mouse from one point in the desired direction.
2. Click at the point to change the direction of the path.
3. Double-click the left mouse button at the last point of the route to complete the route setup.
4. Move the cursor to adjust the detection range and click to set.



After setting, you can move the position of each point.

3.3.6. Circle Fitting Field - circle detection

Set the region of interest to detect the circle.

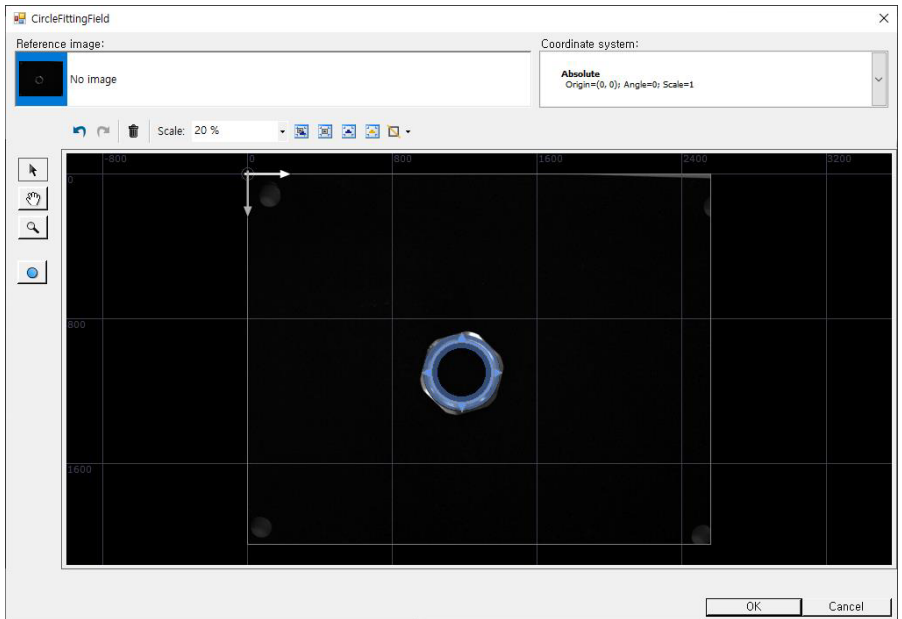

Setup method

1. Drag the mouse as much as the size of the circle from the center point of the circle to be measured.
2. Move the cursor to adjust the detection range and click to set.
3. After completing the settings, click **OK**.

3.4. Model Setup

3.4.1. Edge Model

Create geometric patterns based on edges.

3.4.1.1. Basic Mode

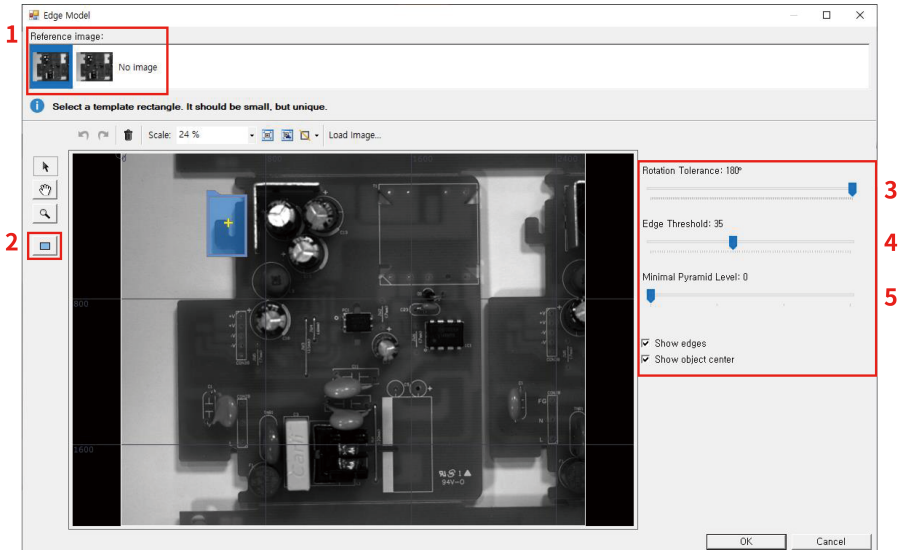

1: Reference image

Select an item to use as the reference image.

2: Draw rectangle

Set the area for model creation.

For maximum performance, make the area as small as possible. The smaller the area, the faster the processing speed and the smaller the storage capacity.

3: Rotation Tolerance

Set the allowable rotation angle of the shape.

The smaller the rotational tolerance, the faster the processing speed and the smaller the storage capacity. (Setting range: -180 to +180°)

4: Edge Threshold

Set the reference level of the edge to be detected. If the value is high, only edges with sharp differences in brightness (high contrast) are detected, and when the value is low, edges with ambiguous differences in brightness (low contrast) are also detected.

The more edges detected, the slower the processing and the higher the storage capacity.

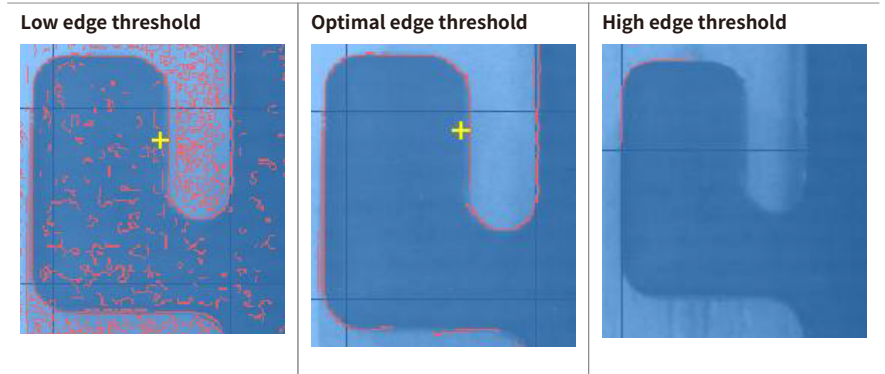

5: Minimal Pyramid Level

Set the minimum pyramid level. For more information, refer to 'Pyramid Level' in 1.7, "Glossary of Terms".

3.4.1.2. Expert Mode

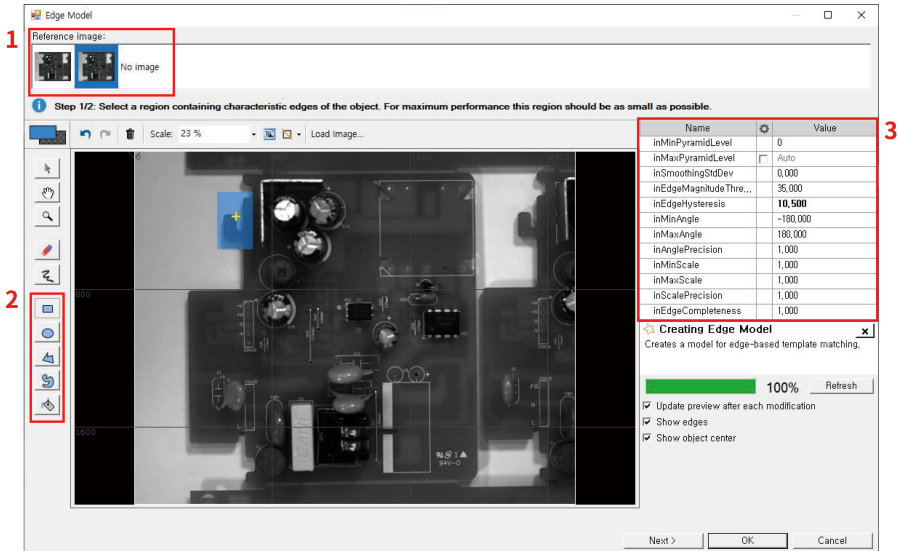

1: Reference image

Select an item to use as the reference image.

2: Drawing tools

Use the drawing tools to set the area.

For maximum performance, make the area as small as possible. The smaller the area, the faster the processing speed and the smaller the storage capacity.

3: Parameter

inMinPyramidLevel / inMaxPyramidLevel - Min/Max pyramid level

Set min/max pyramid level. For more information, refer to 'Pyramid Level' in 1.7, "Glossary of Terms".

inSmoothingStdDev - Smoothing intensity

Smooths the image to remove noise. If there is a lot of noise around, set the number higher.

inEdgeMagnitudeThreshold - Edge threshold

Same as 'Edge Threshold' entry in basic mode.

inEdgeHystersis - Edge Hysteresis

Set a threshold based on neighboring edges. Judgment determines ambiguous edges based on the state of neighboring edges. For details, refer to 'Edge Hysteresis' in 1.7, "Glossary of Terms".

inMinAngle/inMaxAngle - Min / Max angle

Same as 'Rotation Tolerance' item in basic mode.

inAnglePrecision - Angle precision

Set the inspection precision for the angle of rotation. Smaller numbers result in faster processing but less accuracy.

inMinScale/inMaxScale - Min/Max size

Set the min/max size of the object to be detected. When detecting large objects, processing takes a long time.

inScalePrecision - Size precision

Set the precision for the size. Smaller numbers result in faster processing but less accuracy.

inEdgeCompleteness - Edge completeness

Set for only some of the object's edges available. Using only a fraction of it speeds up processing and reduces storage capacity, but reduces accuracy.

3.4.2. Pixel Model

Create geometric patterns on a pixel-by-pixel basis.

3.4.2.1. Basic Mode

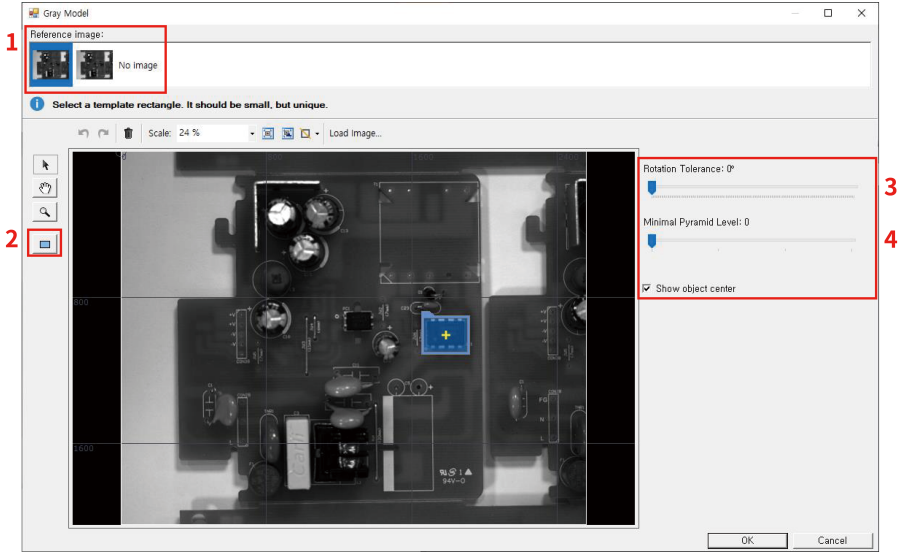

1: Reference image

Select an item to use as the reference image.

2: Draw rectangle

Set the area for model creation.

For maximum performance, make the area as small as possible. The smaller the area, the faster the processing speed and the smaller the storage capacity.

3: Rotation Tolerance

Set the allowable rotation angle of the shape.

The smaller the rotational tolerance, the faster the processing speed and the smaller the storage capacity. (Setting range: -180 to +180°)

4: Minimal Pyramid Level

Set the minimum pyramid level. For more information, refer to 'Pyramid Level' in 1.7, "Glossary of Terms".

3.4.2.2. Expert Mode

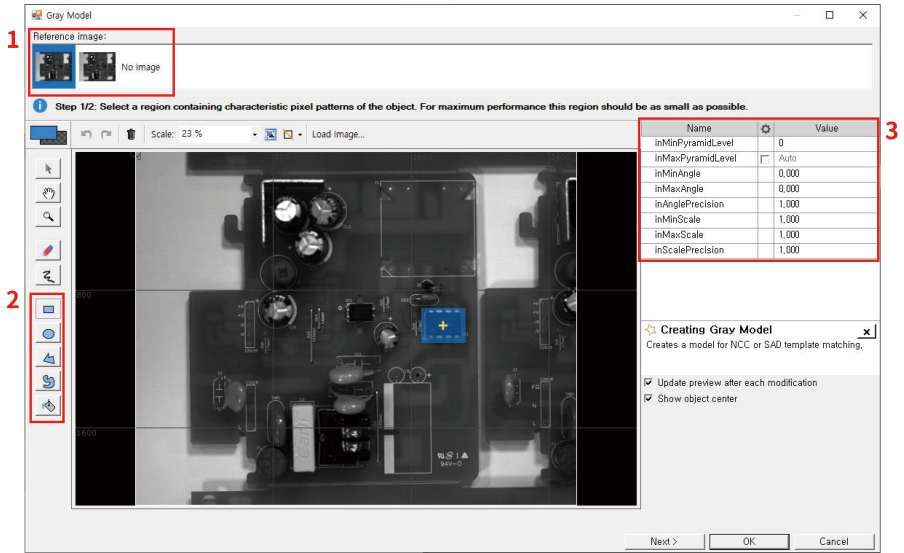

1: Reference image

Select an item to use as the reference image.

2: Drawing tools

Use the drawing tools to set the area.

For maximum performance, make the area as small as possible. The smaller the area, the faster the processing speed and the smaller the storage capacity.

3: Parameter

inMinPyramidLevel / inMaxPyramidLevel - Min/Max pyramid level

Set Min/Max Pyramid Level. For more information, refer to 'Pyramid Level' in 1.7, "Glossary of Terms".

inMinAngle/inMaxAngle - Min / Max angle

Same as 'Rotation Tolerance' item in basic mode.

inAnglePrecision - Angle precision

Set the inspection precision for the angle of rotation. Smaller numbers result in faster processing but less accuracy.

inMinScale/inMaxScale - Min/Max size

Set the min/max size of the object to be detected. When detecting large objects, processing takes a long time.

inScalePrecision - Size precision

Set the precision for the size. Smaller numbers result in faster processing but less accuracy.

3.4.3. Geometry Model

Create geometric patterns based on edges.

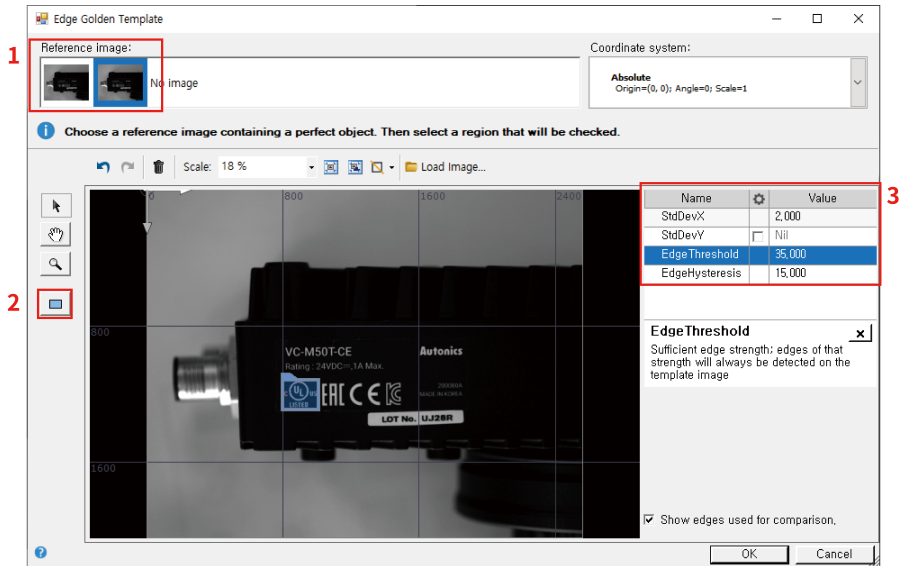

1: Reference image - Reference image

Select an item to use as the reference image.

2: Draw rectangle

Set the area for model creation.

For maximum performance, make the area as small as possible. The smaller the area, the faster the processing speed and the smaller the storage capacity.

3: Parameter

StdDevX-Edge horizontal smoothing value

Set the amount of horizontal smoothing used for edge detection.



StdDevY-Edge vertical smoothing value

Set the amount of vertical smoothing used for edge detection.



When Auto is selected, it is automatically set to the same value as the StdDevX item.

EdgeThreshold-Edge threshold

Set the threshold for edge detection. If the value is high, only edges with sharp differences in brightness (high contrast) are detected. When the value is low, edges with ambiguous differences in brightness (low contrast) are also detected.



EdgeHysteresis - Edge Hysteresis

Set a threshold based on neighboring colors. Judgment determines ambiguous edges based on the color of neighboring edges. For details, refer to 'Edge Hysteresis' in 1.7, "Glossary of Terms".



For more information on smoothing, refer to 3.5.5.9, "Smoothing".

3.4.4. Extraction Model

A model that separates the background from the text.

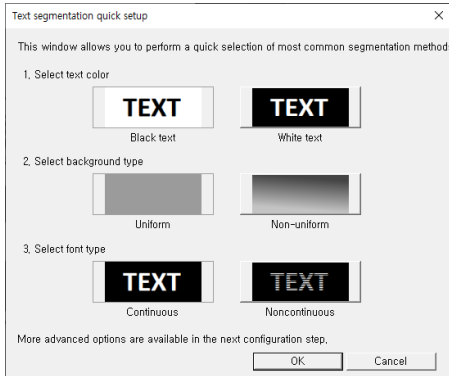

1. In the 'Text segmentation quick setup' window, select a text type from among the items below and click **OK**.

Character type

- Select text Color
 - Black text: Dark text on a light background
 - White text: Light text on a dark background
- Select background type
 - Uniform: When the background is uniform
 - Non-uniform: When the background has various colors
- Select font type
 - Continuous: Consecutive characters, undamaged characters
 - Noncontinuous: Dotted or corrupted characters

2. When the 'Text segmentation - Text Segmentation Designer' window opens, set the details referring to the following 'Detailed settings'.

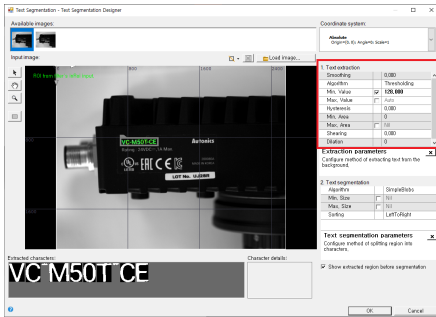

3.4.4.1. Detailed Settings

Text Extraction

Algorithm: Thresholding (threshold mode)

It is used when the brightness is clear and the background and text are clearly distinguished and there is no change in brightness.

Setting items

- Smoothing: Remove noise
- Min.Value: Minimum pixel value (when Auto is off, if the pixel value is lower than the set value, it is not detected)
- Max.Value: Maximum pixel value (if the pixel value is higher than the set value, it is not detected)
- Hysteresis: Threshold tolerance level based on neighboring colors
- Min.Area: Minimum allowable area pixels (excluded from the area when the number of pixels in the detected area is less than the set value)
- Max.Area: Maximum allowable area pixels (excluded from the area when the number of pixels in the detected area is greater than the set value)
- Shearing: Applies the slope of the detection area
- Dilation: Extends the Y-axis direction of the detection area

Algorithm: Dynamic (dynamic mode)

It is used when the brightness is not clear and there is a lot of change in brightness.

Setting items

- Smoothing: Remove noise
- Min.Difference: Minimum difference in the color of the average neighboring pixel (if the color difference from the neighboring pixel is lower than the set value, it is not detected)
- Max.Difference: Maximum difference in the color of the average neighboring pixel (if the color difference from the neighboring pixel is higher than the set value, it is not detected)
- Radius: Kernel radius (the number of adjacent pixels to calculate the average value of the corresponding pixel)
- Hysteresis: Threshold tolerance level based on neighboring colors
- Min.Area: Minimum allowable area pixels (excluded from the area when the number of pixels in the detected area is less than the set value)
- Max.Area: Maximum allowable area pixels (excluded from the area when the number of pixels in the detected area is greater than the set value)
- Shearing: Applies the slope of the detection area
- Dilation: Extends the Y-axis direction of the detection area

Algorithm: Automatic (auto mode)

The details are automatically set as shown below.

Setting items

- Smoothing: Remove noise
- Method: Algorithm to find automatic threshold
 - ClusteringKittler: Minimum error threshold
 - ClusteringkMeans: Using K-means clustering
 - ClusteringOtsu: Using the Otsu method (fast and best method for most images)
 - Entropy: Varies with the entropy of the image histogram (suitable for images with fewer foreground pixels)
 - HistogramIntermodes: Assuming the image histogram is binomial, smooth the histogram until there are only two local maxima and return the average
- Black Text: Whether to search for black text
- Hysteresis: Threshold tolerance level based on neighboring colors
- Min.Area: Minimum allowable area pixels (excluded from the area when the number of pixels in the detected area is less than the set value)
- Max.Area: Maximum allowable area pixels (excluded from the area when the number of pixels in the detected area is greater than the set value)
- Shearing: Applies the slope of the detection area
- Dilation: Extends the Y-axis direction of the detection area



For more information on hysteresis, refer to 1.7, “Glossary of Terms” 'hysteresis'.

Text segmentation

Algorithm: SimpleBlobs (simple region mode)

It simply separates the separated regions with a single character.

Setting items

- Min. Size: Minimum horizontal and vertical size (excluding areas with lower pixel count than the set value)
- Max. Size: Maximum horizontal and vertical size (excluding areas with a higher number of pixels than the set value)
- Sorting: Reading direction
 - None: Aligns randomly
 - LeftToRight: Aligns left to right
 - RightToLeft: Aligns right to left
 - TopToBottom: Aligns from top to bottom

Algorithm: Projection (projection mode)

It is used when the characters have the same width.

Setting items

- Char. Width: Minimum width of characters
- Smoothing: Remove noise near text
- Min. Size: Minimum horizontal and vertical size (excluding areas with lower pixel count than the set value)
- Max. Size: Maximum horizontal and vertical size (excluding areas with a higher number of pixels than the set value)
- Sorting: Reading direction
 - None: Aligns randomly
 - LeftToRight: Aligns left to right
 - RightToLeft: Aligns right to left
 - TopToBottom: Aligns from top to bottom

Algorithm: BlobDistance (area distance mode)

It is used when the distance between characters is the same.

Setting items

- Distance: Minimum distance between areas
- Balance: Ratio of calculated distance between regions (X/Y)
- Min. Size: Minimum horizontal and vertical size (excluding areas with lower pixel count than the set value)
- Max. Size: Maximum horizontal and vertical size (excluding areas with a higher number of pixels than the set value)
- Sorting: Reading direction
 - None: Aligns randomly
 - LeftToRight: Aligns left to right
 - RightToLeft: Aligns right to left

3.4.5. OCR Model

A model that trains characters.

3.4.5.1. If there is area data to be trained

1. Hover your mouse over the text to select it, then enter the text that the area represents.

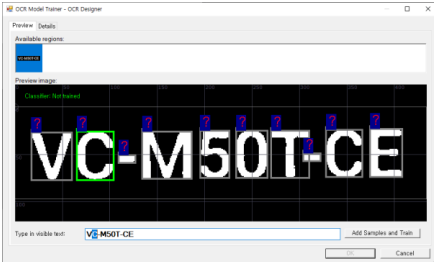

2. Click **Add Samples and Train**.

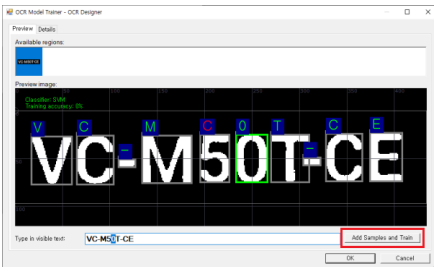

3. After confirming that the text in the area is the same as the text in the upper left corner, click **OK**.

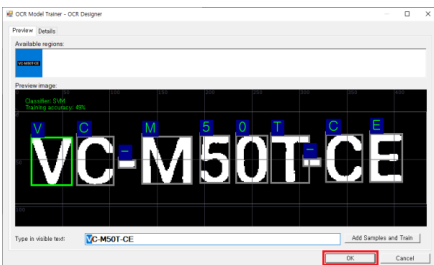

3.4.5.2. If there is no area data to train (create sample)

1. Go to the Details tab, then **Create Samples...** Click.

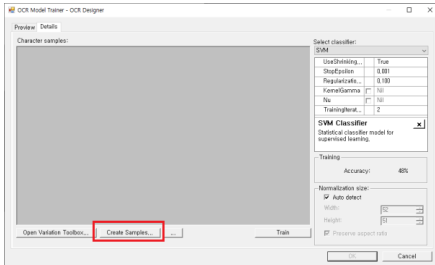

2. Choose the font and style you want.

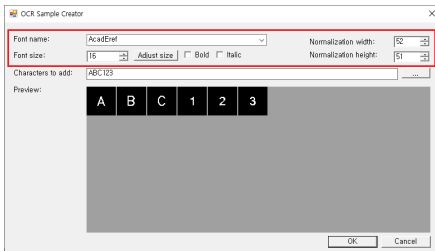

3. Enter the characters you want to add into Characters to add and click **OK**.

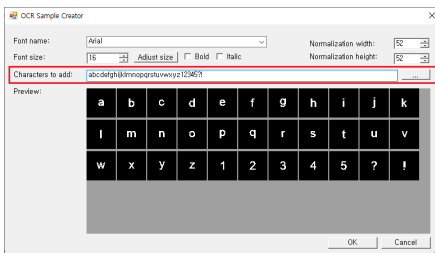

4. Click **Train** and then click **OK**.

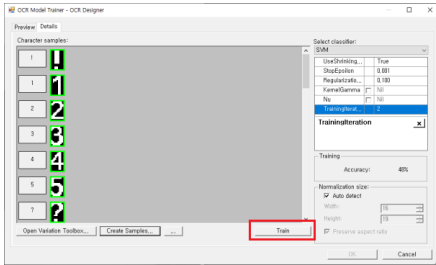

3.4.5.3. Creating a sample using existing data

1. Go to the Details tab and click on the text field you want to sample.

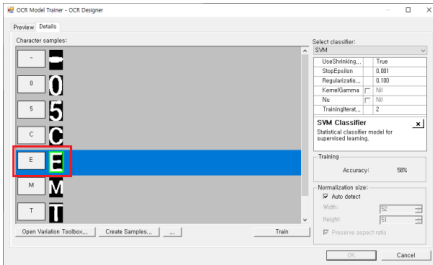

2. Click the **Open Variation Toolbox** button.

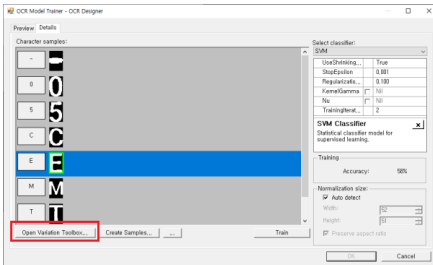

3. Select the desired variant type and click **Create Variants**.

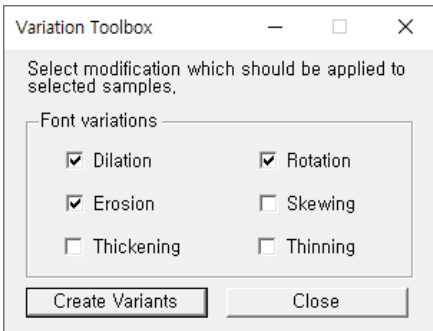

- Dilation: Creates a dilated sample.
- Rotation: Creates a rotated sample.
- Erosion: Creates an eroded sample.

- Skewing: Creates a skewed sample.
- Thickening: Creates a thick sample.
- Thinning: Creates a thin sample.

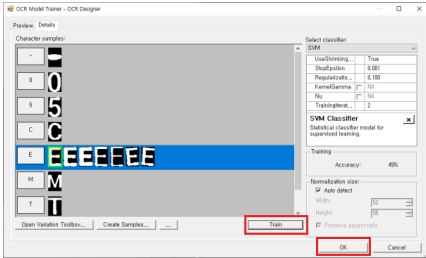

4. Click **Train** and then click **OK**.

3.5. Inspection Items

3.5.1. Alignment

Alignment compares the features of the input image based on the registered edge model, searches for the position of the shape most similar to the edge model, and obtains the position and rotation angle of the searched shape.

If the similarity of the shape is larger than the set value, outputs Pass, and if smaller, outputs Fail.

The purpose of alignment (alignment) is to correct the position of the existence and shape inspection of a moving object, and other inspections by using the position and rotation angle information of the registered shape and the searched shape to correct the position deviation of the object.

01 Alignment	
Image	Result
ROI	ROI
Edge Model	Detected Position
Edge Threshold	Similarity (%)
Similarity (%)	Center Point
	Alignment

Input parameters

Name	Function	Modbus settings
Image	Set the input image.	-
ROI	Set the inspection area. (refer to 3.3.3, "Region - Multiple shapes")	-
Edge Model	Set the object's geometric model (edge-based). (refer to 3.4, "Model Setup")	-
Edge Threshold	Set the threshold for edge detection. If the threshold is high, only edges with sharp differences in brightness (high contrast) are detected, and when the threshold is low, edges with ambiguous differences in brightness (low contrast) are also detected.	<input type="radio"/>
Similarity (%)	Set the minimum similarity (%) between the registered shape and the detected shape. If the similarity rate of the shape is greater than the input similarity rate, it is recognized as the same shape.	<input type="radio"/>

Output parameters

Name	Function	Modbus settings
Result	Determines whether the detected similarity rate is within the allowable range.	○
ROI	Displays the set inspection area.	-
Detected Position	Displays the area of the detected shape.	X, Y, angle, width, height
Similarity (%)	Outputs the similarity (%) between the registered shape and the input image.	○
Center Point	Displays the center point coordinates of the detected shape.	X, Y
Alignment	Outputs the coordinate values of the shape compared to the origin to correct the position.	-

3.5.1.1. Inspection result

Alignment

Pass: shape detection



Fail: shape not detected



Detect when position is moved

Existing location



Moved location



Combination of alignment inspection with other inspection items

If the alignment inspection is higher than other inspection items, they should be connected. When not set, the set coordinates are checked, not the calibrated coordinates.

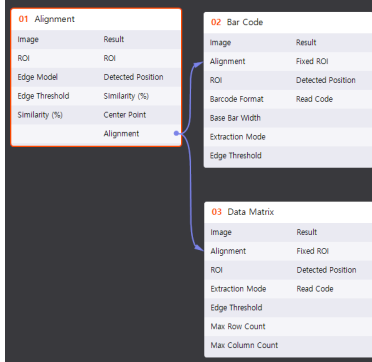

3.5.2. Identify

3.5.2.1. Barcode

Locates the 1D barcode in the ROI area set by the user and read the code.

Basic mode	Expert mode																														
<div style="border: 1px solid red; padding: 5px;"> <p>01 Bar Code</p> <table border="1"> <tr><td>Image</td><td>Result</td></tr> <tr><td>Alignment</td><td>Fixed ROI</td></tr> <tr><td>ROI</td><td>Detected Position</td></tr> <tr><td>Barcode Format</td><td>Read Code</td></tr> <tr><td>Base Bar Width</td><td></td></tr> <tr><td>Extraction Mode</td><td></td></tr> <tr><td>Edge Threshold</td><td></td></tr> </table> </div>	Image	Result	Alignment	Fixed ROI	ROI	Detected Position	Barcode Format	Read Code	Base Bar Width		Extraction Mode		Edge Threshold		<div style="border: 1px solid red; padding: 5px;"> <p>01 Bar Code</p> <table border="1"> <tr><td>Image</td><td>Result</td></tr> <tr><td>Alignment</td><td>Fixed ROI</td></tr> <tr><td>ROI</td><td>Detected Position</td></tr> <tr><td>Barcode Format</td><td>Read Code</td></tr> <tr><td>Base Bar Width</td><td></td></tr> <tr><td>Extraction Mode</td><td></td></tr> <tr><td>Scan Width</td><td></td></tr> <tr><td>Edge Threshold</td><td></td></tr> </table> </div>	Image	Result	Alignment	Fixed ROI	ROI	Detected Position	Barcode Format	Read Code	Base Bar Width		Extraction Mode		Scan Width		Edge Threshold	
Image	Result																														
Alignment	Fixed ROI																														
ROI	Detected Position																														
Barcode Format	Read Code																														
Base Bar Width																															
Extraction Mode																															
Edge Threshold																															
Image	Result																														
Alignment	Fixed ROI																														
ROI	Detected Position																														
Barcode Format	Read Code																														
Base Bar Width																															
Extraction Mode																															
Scan Width																															
Edge Threshold																															

Input parameters

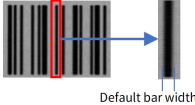
Name	Function	Modbus settings
Image	Set the input image.	-
Alignment	Enter a value to correct the position of the area of interest.	-
ROI	Set the inspection area. (refer to 3.3.1, "Rectangle2D - Rectangle")	X, Y, angle, width, height
Barcode Format	Set the barcode format. - Setting range: Auto, EAN13, EAN13Addon2, EAN13Addon5, EAN8, EAN8Addon2, EAN8Addon5, UPCA, UPCAAddon2, PCAAddon5, UPCE, UPCEAddon2, UPCEAddon5, CODE128, CODE39, CODE93, Interleaved2of5, Pharmacode, PharmacodeInversed	-
Base Bar Width	Set the expected width, in pixels, of the thinnest bars of a 1D barcode. 	<input type="radio"/>
Extraction Mode	Set the mode to extract the area. - Bright on Dark: Detects areas brighter than the background. - Dark on Bright: Detects areas darker than the background. - Any: Detects both areas darker or brighter than the background, and the speed is slower than unidirectional.	-

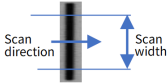
Name	Function	Modbus settings
Scan Width	Set the width of the scan areas in pixels. 	<input type="radio"/>
Edge Threshold	Set the threshold for edge detection. If the threshold is high, only edges with sharp differences in brightness (high contrast) are detected, and when the threshold is low, edges with ambiguous differences in brightness (low contrast) are also detected.	<input type="radio"/>

Output parameters

Name	Function	Modbus settings
Result	Determines whether the barcode is read or not.	<input type="radio"/>
Fixed ROI	Displays the inspection area with alignment applied.	X, Y, angle, width, height
Detection Position	Displays the location of the read code.	-
Read Code	Outputs the read code.	<input type="radio"/>

Inspection result

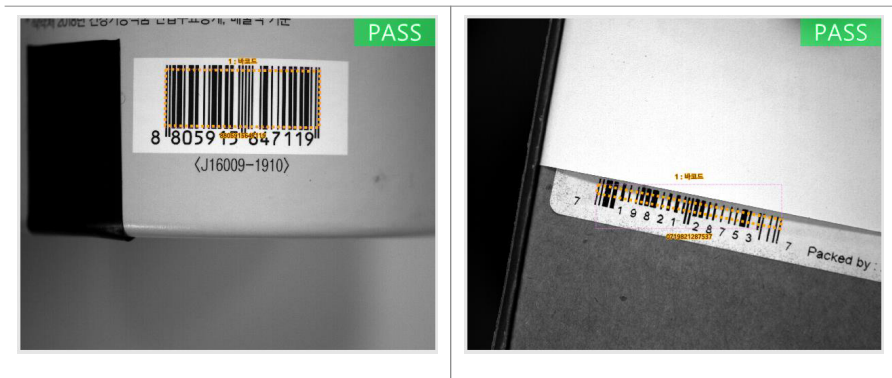

3.5.2.2. Data Matrix

Finds the data matrix in the ROI area set by the user and reads the corresponding code.

01 Data Matrix	
Image	Result
Alignment	Fixed ROI
ROI	Detected Position
Extraction Mode	Read Code
Edge Threshold	
Max Row Count	
Max Column Count	

Input parameters

Name	Function	Modbus settings
Image	Set the input image.	-
Alignment	Enter a value to correct the position of the area of interest.	-
ROI	Set the inspection area (refer to 3.3.1, “Rectangle2D - Rectangle”)	X, Y, angle, width, height
Extraction Mode	Set the mode to extract the area. - Bright on Dark: Detects areas brighter than the background. - Dark on Bright: Detects areas darker than the background. - Any: Detects both areas darker or brighter than the background, and the speed is slower than unidirectional.	-
Edge Threshold	Set the threshold for edge detection. If the threshold is high, only edges with sharp differences in brightness (high contrast) are detected, and when the threshold is low, edges with ambiguous differences in brightness (low contrast) are also detected.	<input type="radio"/>
Max Row Count	Set the maximum number of rows in a cell. If a code with more lines than the set value is entered, it cannot be read.	<input type="radio"/>
Max Column Count	Set the maximum number of columns in a cell. If a code with more lines than the set value is entered, it cannot be read.	<input type="radio"/>



For more information, about cells, refer to 1.7, “Glossary of Terms” .

Output parameters

Name	Function	Modbus settings
Result	Determines whether the data matrix is read or not.	○
Fixed ROI	Displays the inspection area with alignment applied.	X, Y, angle, width, height
Detected Position	Displays the location of the read code.	-
Read Code	Outputs the read code.	○

Inspection result

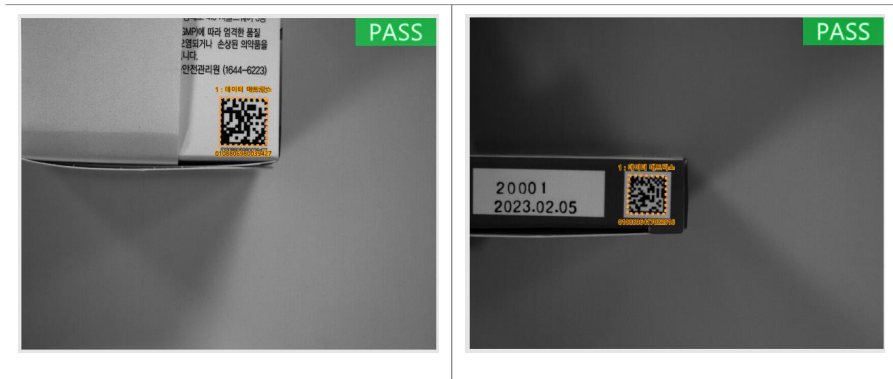

3.5.2.3. QR Code

Finds the QR code in the ROI area set by the user and reads the code.

01 QR Code	
Image	Result
Alignment	Fixed ROI
ROI	Detected Position
Min Cell Size	Read Code
Edge Threshold	
Extraction Mode	

Input parameters

Name	Function	Modbus settings
Image	Set the input image.	-
Alignment	Enter a value to correct the position of the area of interest.	-
ROI	Set the inspection area. (Refer to 3.3.1, “Rectangle2D - Rectangle”)	X, Y, angle, width, height
Min Cell Size	Set the expected size of the cell, in pixels.	<input type="radio"/>
Edge Threshold	Set the threshold for edge detection. If the threshold is high, only edges with sharp differences in brightness (high contrast) are detected, and when the threshold is low, edges with ambiguous differences in brightness (low contrast) are also detected.	<input type="radio"/>
Extraction Mode	Set the mode to extract the area. - Bright on Dark: Detects areas brighter than the background. - Dark on Bright: Detects areas darker than the background. - Any: Detects both areas darker or brighter than the background, and the speed is slower than unidirectional.	-



For more information about cells, refer to 1.7, “Glossary of Terms”.

Output parameters

Name	Function	Modbus settings
Result	Determines whether the QR code is read or not.	<input type="radio"/>
Fixed ROI	Displays the inspection area with alignment applied.	X, Y, angle, width, height
Detected Position	Displays the location of the read code.	-
Read Code	Outputs the read code.	<input type="radio"/>

Inspection result

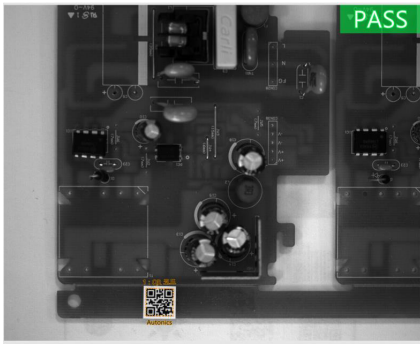

3.5.2.4. Extract/Read Character

It detects and reads characters within the region of interest.

In the binarized image, an object that can be recognized as a character is found, and the corresponding character is read by comparing it with the previously learned character sample data.

If there is a limit to reading from the existing sample data, the user can register the sample and learn it.

The more sample data, the higher the character recognition rate.

To read characters, two inspections, extract character and read character, are required.

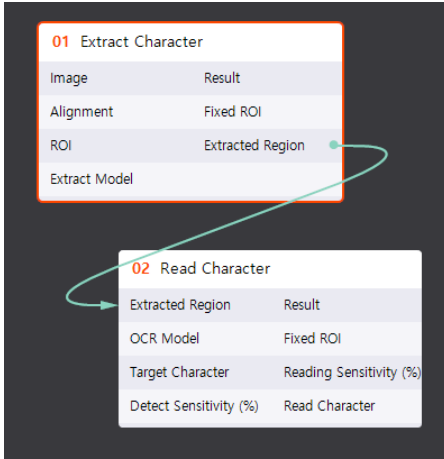

Extract Characters

Input parameters

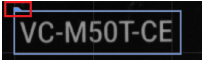

Name	Function	Modbus settings
Image	Set the input image.	-
Alignment	Enter a value to correct the position of the area of interest.	-
ROI	Set the inspection area. (refer to 3.3.1, “Rectangle2D - Rectangle”) For setting a rectangle, the position of the origin should be set at the top left of the text. 	X, Y, angle, width, height
Extraction Model	Set the model for text area extraction. (refer to 3.4.4, “Extraction Model”)	-

Output parameters

Name	Function	Modbus settings
Result	Determines whether to extract the text area.	<input type="radio"/>
Fixed ROI	Displays the inspection area with alignment applied.	X, Y, angle, width, height output
Extract Region	Outputs the extracted text area. Used to read characters in connected with read character.	-

Read Character

Input parameters

Name	Function	Modbus settings
Extracted Region	Enter the text area for reading into the OCR model. [character_extract] Connect with the extract character field item of the output parameter.	-
OCR Model	Trains a shape or font to the model. (refer to 3.4.5, "OCR Model" item)	-
Target Character	Set the character to be compared with the detected character result for judgment. <div style="display: flex; align-items: center;"> <div style="margin-right: 10px;">When setting VC:</div>  </div> <div style="display: flex; align-items: center;"> <div style="margin-right: 10px;">When setting VA:</div>  </div>	<input type="radio"/>
Detection Sensitivity (%)	Set the character detection sensitivity. When comparing OCR model data and extraction area, the sensitivity is output proportional to the amount of data of the area is learned in the model. If the sensitivity of the area is lower than the set sensitivity, characters are not read. When set to 0, the most similar character among registered characters is output.	<input type="radio"/>



Notes when setting the 'Target Character' parameter

- * Set only when comparison with the target character is required.
- * Do not set when used for reading simple characters.
- * Do not set a space for the target character.

Output parameters

Name	Function	Modbus settings
Result	If target character is set: Matches the read character If the target character is not set: Determines whether a character is detected.	<input type="radio"/>
Fixed ROI	Displays the inspection area with alignment applied.	X, Y, angle, width, height
Reading Sensitivity (%)	Outputs the sensitivity of each character read. Sensitivity is output according to the amount of data trained in the OCR model. If there are many outputs, the sensitivity is high.	<input type="radio"/>
Read Character	Outputs the reading character.	<input type="radio"/>

Inspection result

Pass

Target Character: VC-M50T-CE

Reading Character: VC-M50T-CE



Fail

Target Character: VC-M50T-CA

Reading Character: VC-M50T-CE



3.5.3. Measure

3.5.3.1. Area

The number of pixels above a certain brightness is determined by comparing the ROI area set by the user with the ROI area of the input image.

Set upper and lower discriminant values in the registered ROI area to determine whether the area measured by the object is within the discriminant value range.

If the number of detected pixels within the set ROI is within the discriminant value, it outputs pass, and if out of range, it outputs fail.

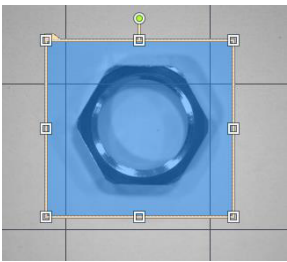
<div style="border-bottom: 1px solid gray; padding: 5px 5px 0 5px;"> 01 Area </div> <table border="1" style="border-collapse: collapse; width: 100%; border: none;"> <tr> <td style="border: none; padding: 2px 5px;">Image</td> <td style="border: none; padding: 2px 5px;">Result</td> </tr> <tr> <td style="border: none; padding: 2px 5px;">Alignment</td> <td style="border: none; padding: 2px 5px;">Fixed ROI</td> </tr> <tr> <td style="border: none; padding: 2px 5px;">ROI</td> <td style="border: none; padding: 2px 5px;">Detection Area</td> </tr> <tr> <td style="border: none; padding: 2px 5px;">Binary Threshold</td> <td style="border: none; padding: 2px 5px;">Area Size</td> </tr> <tr> <td style="border: none; padding: 2px 5px;">Extraction Mode</td> <td style="border: none;"></td> </tr> <tr> <td style="border: none; padding: 2px 5px;">Min Area</td> <td style="border: none;"></td> </tr> <tr> <td style="border: none; padding: 2px 5px;">Max Area</td> <td style="border: none;"></td> </tr> </table>	Image	Result	Alignment	Fixed ROI	ROI	Detection Area	Binary Threshold	Area Size	Extraction Mode		Min Area		Max Area		
Image	Result														
Alignment	Fixed ROI														
ROI	Detection Area														
Binary Threshold	Area Size														
Extraction Mode															
Min Area															
Max Area															

Input parameters

Name	Function	Modbus settings
Image	Set the input image.	-
Alignment	Enter a value to correct the position of the area of interest.	-
ROI	Set the inspection area. (refer to 3.3.3, “Region - Multiple shapes”)	-
Binary Threshold	Set the threshold for image binarization. Measures the number of regions by converting 0 below the threshold to 1 and above the threshold.	○
Extraction Mode	Set the mode to extract the area. - Bright on Dark: Detects areas brighter than the background. - Dark on Bright: Detects areas darker than the background.	-
Min/Max Area	Set the minimum/maximum range of the area. - Setting range: 0 to 5242880	○

Output parameters

Name	Function	Modbus settings
Result	Determines whether the detected area is within the allowable range.	○
Fixed ROI	Displays the inspection area with alignment applied.	-
Detected Area	Displays the detected area.	-
Area Size	Outputs the size of the detected area.	○

Inspection result

Standard: 100000 to 200000

Pass

Area size: 144638

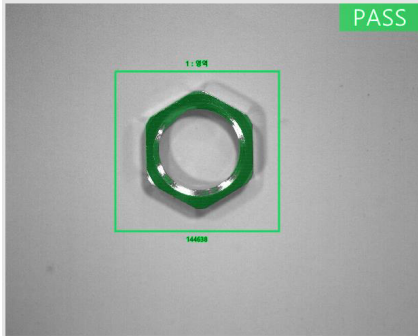

Fail

Realm size: 61762

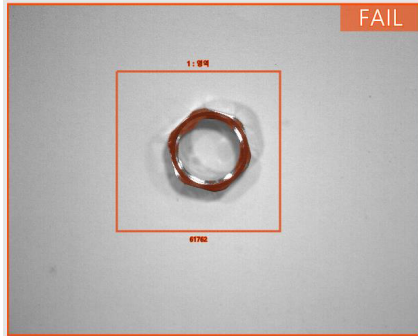

Standard: 80000 to 85000

Pass

Area size: 83275

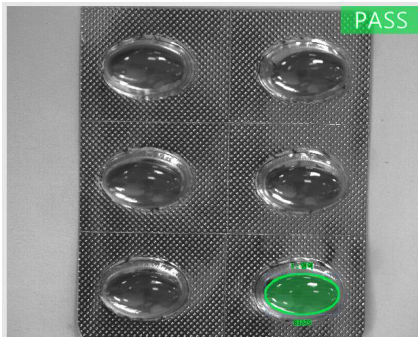

Fail

Realm size: 22344



3.5.3.2. Angle

Inspects the angle between two edges. The unit of angle is ° (degrees).

Measures the angle between the edges using the edges of two points of interest.

Set the pass range based on the angle between two edges registered by the user.

01 Angle	
Image	Result
Alignment	Fixed ROI
A ROI	Intersection
A Edge Threshold	Detected Position
A Search Direction	Angle
A Extraction Mode	
B ROI	
B Edge Threshold	
B Search Direction	
B Extraction Mode	
Min Angle	
Max Angle	

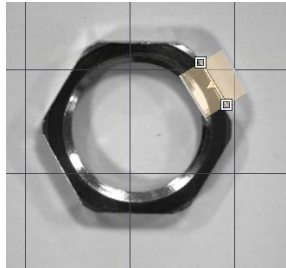

Input parameters

Name	Function	Modbus settings
Image	Set the input image.	-
Alignment	Enter a value to correct the position of the area of interest.	-
A/B ROI	Set the A/B examination area. (refer to 3.3.4, “Segment Fitting Field - Line Segment Fitting Field”)	Start X,Y, end X,Y, width
A/B Edge Threshold	Set the threshold for A/B edge detection. If the threshold is high, only edges with sharp differences in brightness (high contrast) are detected, and when the threshold is low, edges with ambiguous differences in brightness (low contrast) are also detected.	<input type="radio"/>
A/B Search Direction	Set the edge search direction for area A/B. - Bright area → Dark area: Searches from light to dark. - Dark area → Bright area: Searches from dark to light. - Any: Searches regardless of brightness.	-

Name	Function	Modbus settings
A/B Extraction Mode	Select the edge of area A/B. - Best: Selects the best edge. - First: Selects the first detected edge in the search direction. - Last: Selects the last detected edge in the search direction.	-
Min/Max Angle	Set the minimum/maximum range of angles. - Setting range: 0 to 180	○

Output parameters

Name	Function	Modbus settings
Result	Determines whether the detected angle is within the allowable range.	○
Fixed ROI	Displays the inspection area with alignment applied.	Start point X,Y, end point X,Y
Intersection	Displays the intersection of the inspection area and the detected edge.	○
Detected Position	Displays the line formed by the detected edges.	-
Angle	Outputs the detected angle value.	○

Inspection result

Standard: 60 to 62

Pass

Angle: 60.25

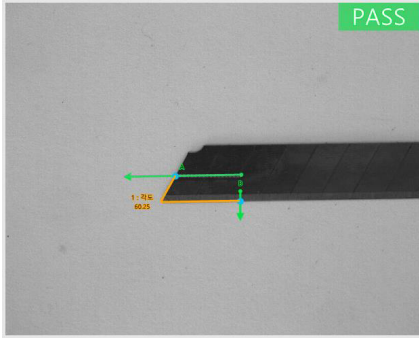

Fail

Angle: 96.02

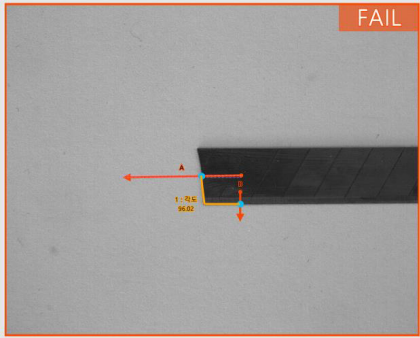

Standard: 88 to 92

Pass

Angle: 89.22

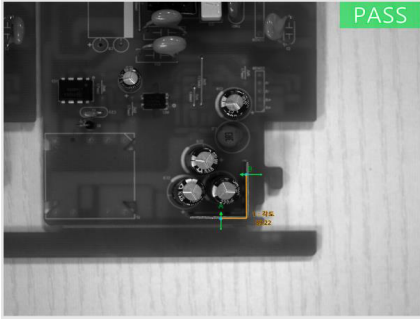

Fail

Angle: No edge detected

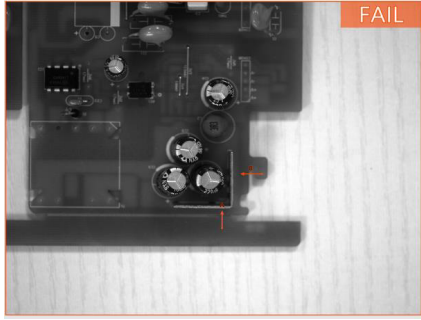

3.5.3.3. Brightness

Checks whether the average brightness of the region of interest registered by the user is within the maximum and minimum brightness range.

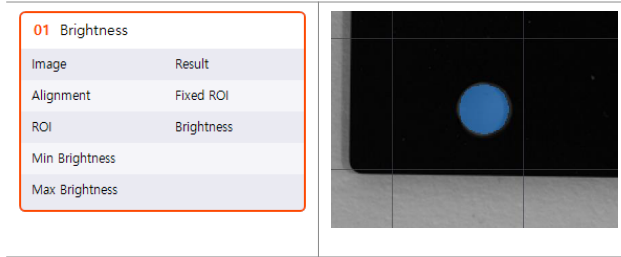

Input parameters

Name	Function	Modbus settings
Image	Set the input image.	-
Alignment	Enter a value to correct the position of the area of interest.	-
ROI	Set the scan area. (refer to 3.3.3, "Region - Multiple shapes")	-
Min/Max Brightness	Set the minimum/maximum range of brightness. - Setting range: 0 to 255	<input type="radio"/>

Output parameters

Name	Function	Modbus settings
Result	Determines whether the detected brightness is within the allowable range.	<input type="radio"/>
Fixed ROI	Displays the inspection area with alignment applied.	-
Brightness	Outputs the average brightness value.	<input type="radio"/>

Inspection result

Standard: 80 to 100

Pass

Brightness: 89.72

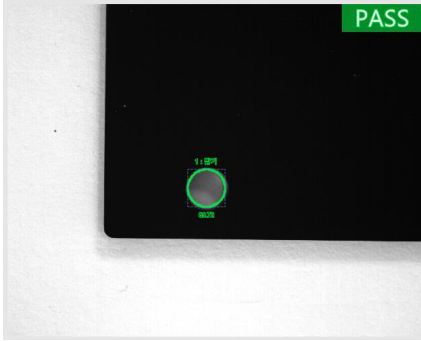

Fail

Brightness: 2.25



3.5.3.4. Contrast

Contrast refers to the amount representing the difference in brightness between the dark and bright areas within the region of interest.

By comparing the contrast of the ROI area set by the user with the contrast of the input image ROI area, it determines changing the contrast based on the contrast value.

It determines whether there is a change in contrast by checking whether the contrast of the region of interest registered by the user is within the allowable range.

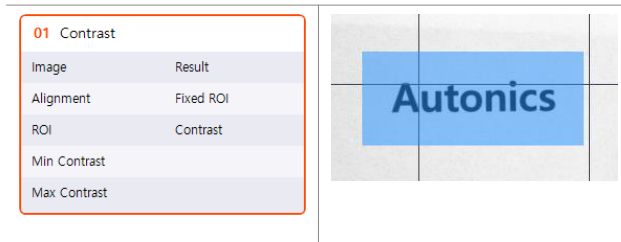

Input parameters

Name	Function	Modbus settings
Image	Set the input image.	-
Alignment	Enter a value to correct the position of the area of interest.	-
ROI	Set the inspection area. (refer to 3.3.3, "Region - Multiple shapes")	-
Min/Max Contrast	Set the minimum/maximum range of contrast. - Setting range: 0 to 100	<input type="radio"/>

Output parameters

Name	Function	Modbus settings
Result	Determines whether the detected contrast is within the allowable range.	<input type="radio"/>
Fixed ROI	Displays the inspection area with alignment applied.	-
Contrast	Outputs the average contrast value.	<input type="radio"/>

Inspection result

Standard: 80 to 90

Pass

Contrast: 83.44

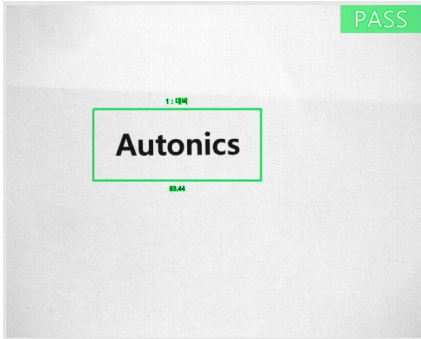

Fail

Contrast: 24.86

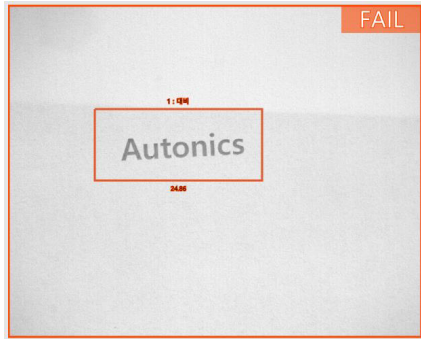

3.5.3.5. Diameter

The circle is detected within the two areas registered by the user (minimum range and maximum range of the circle), and the image is displayed in the set area.

Measures the diameter of a circle in pixels using its edges.

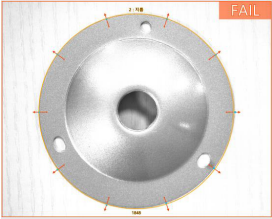
Basic mode	Expert mode																																											
<table border="1"> <thead> <tr> <th colspan="2">01 Diameter</th> </tr> <tr> <th>Image</th> <th>Result</th> </tr> </thead> <tbody> <tr> <td>Alignment</td> <td>Fixed ROI</td> </tr> <tr> <td>ROI</td> <td>Circle Status</td> </tr> <tr> <td>Scan Count</td> <td>Edge Position</td> </tr> <tr> <td>Edge Threshold</td> <td>Circle</td> </tr> <tr> <td>Search Direction</td> <td>Diameter</td> </tr> <tr> <td>Extraction Mode</td> <td></td> </tr> <tr> <td>Min Diameter</td> <td></td> </tr> <tr> <td>Max Diameter</td> <td></td> </tr> </tbody> </table>	01 Diameter		Image	Result	Alignment	Fixed ROI	ROI	Circle Status	Scan Count	Edge Position	Edge Threshold	Circle	Search Direction	Diameter	Extraction Mode		Min Diameter		Max Diameter		<table border="1"> <thead> <tr> <th colspan="2">01 Diameter</th> </tr> <tr> <th>Image</th> <th>Result</th> </tr> </thead> <tbody> <tr> <td>Alignment</td> <td>Fixed ROI</td> </tr> <tr> <td>ROI</td> <td>Circle Status</td> </tr> <tr> <td>Scan Width</td> <td>Edge Position</td> </tr> <tr> <td>Scan Count</td> <td>Circle</td> </tr> <tr> <td>Edge Threshold</td> <td>Diameter</td> </tr> <tr> <td>Search Direction</td> <td></td> </tr> <tr> <td>Extraction Mode</td> <td></td> </tr> <tr> <td>Min Diameter</td> <td></td> </tr> <tr> <td>Max Diameter</td> <td></td> </tr> </tbody> </table>	01 Diameter		Image	Result	Alignment	Fixed ROI	ROI	Circle Status	Scan Width	Edge Position	Scan Count	Circle	Edge Threshold	Diameter	Search Direction		Extraction Mode		Min Diameter		Max Diameter		
01 Diameter																																												
Image	Result																																											
Alignment	Fixed ROI																																											
ROI	Circle Status																																											
Scan Count	Edge Position																																											
Edge Threshold	Circle																																											
Search Direction	Diameter																																											
Extraction Mode																																												
Min Diameter																																												
Max Diameter																																												
01 Diameter																																												
Image	Result																																											
Alignment	Fixed ROI																																											
ROI	Circle Status																																											
Scan Width	Edge Position																																											
Scan Count	Circle																																											
Edge Threshold	Diameter																																											
Search Direction																																												
Extraction Mode																																												
Min Diameter																																												
Max Diameter																																												

Input parameters

Name	Function	Modbus settings
Image	Set the input image.	-
Alignment	Enter a value to correct the position of the area of interest.	-
ROI	Set the inspection area. (refer to 3.3.3, "Region - Multiple shapes")	X, Y, radius, width
Scan Width	Set the surrounding pixel range (scan width) to use when detecting one edge.	<input type="radio"/>
Scan Count	Set the number of scan areas.	<input type="radio"/>
Edge Threshold	Set the threshold for edge detection. If the threshold is high, only edges with sharp differences in brightness (high contrast) are detected, and when the threshold is low, edges with ambiguous differences in brightness (low contrast) are also detected.	<input type="radio"/>
Search Direction	Set the edge search direction for area A/B. - Bright area → Dark area: Searches from light to dark. - Dark area → Bright area: Searches from dark to light. - Any: Searches regardless of brightness.	-

Name	Function	Modbus settings
Detection Mode	Select the edge of the area. - Best: Selects the best edge. - First: Selects the first detected edge in the search direction. - Last: Selects the last detected edge in the search direction.	-
Min/Max Diameter	Set the minimum/maximum range for the diameter. - Setting range: 0 to 2048	○

Output parameters

Name	Function	Modbus settings
Result	Determines whether the detected diameter is within the allowable range.	○
Fixed ROI	Displays the inspection area with alignment applied.	Start point X,Y, end point X,Y
Circle Status	Determines whether the edges form a circle.	○
Edge Position	Displays the positions of the detected edges.	X,Y
Circle	Displays the detected circle.	X, Y, radius
Diameter	Outputs the detected circle diameter.	○

Inspection result

Standard: 1700 to 2000

Pass

Diameter: 1850

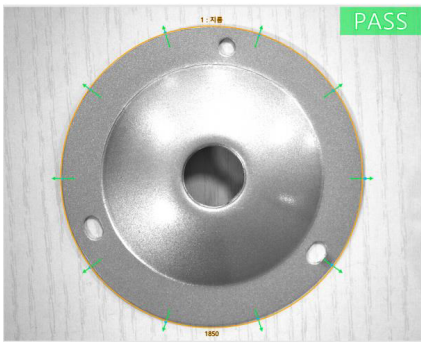

Fail

Diameter: 1562

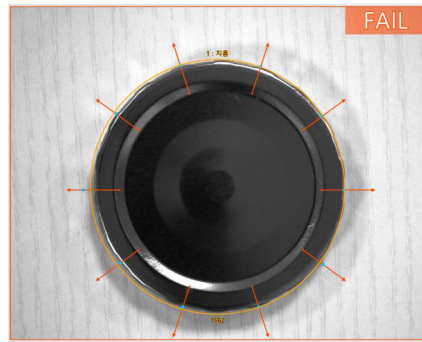

3.5.3.6. Length

The length is inspected based on the distance between the two edges registered by the user, using the intersection between the user-registered arrow and the two edges that the arrow range passes through. Unit is pixel.

01 Length	
Image	Result
Alignment	Fixed ROI
A ROI	Intersection
A Edge Threshold	Detected Position
A Search Direction	Length
A Extraction Mode	
B ROI	
B Edge Threshold	
B Search Direction	
B Extraction Mode	
Min Length	
Max Length	

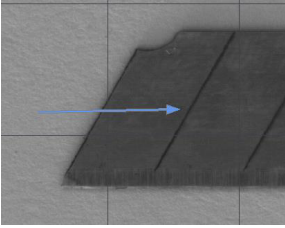

Input parameters

Name	Function	Modbus settings
Image	Set the input image.	-
Alignment	Enter a value to correct the position of the area of interest.	-
A/B ROI	Set the A/B inspection region. (refer to 3.3.2, “Segment2D - Edge detection”)	Start Point X,Y, End Point X,Y Available
A/B Edge Threshold	Set the threshold for A/B edge detection. If the threshold is high, only edges with sharp differences in brightness (high contrast) are detected, and when the threshold is low, edges with ambiguous differences in brightness (low contrast) are also detected.	<input type="radio"/>
A/B Search Direction	Set the edge search direction for area A/B. - Bright area → Dark area: Searches from light to dark. - Dark area → Bright area: Searches from dark to light. - Any: Searches regardless of brightness.	-
A/B Extraction Mode	Select the edge of area A/B. - Best: Selects the best edge. - First: Selects the first detected edge in the search direction. - Last: Selects the last detected edge in the search direction.	-

Name	Function	Modbus settings
Min/Max Length	Set the minimum/maximum range of length. - Setting range: 0 to 3278	<input type="radio"/>

Output parameters

Name	Function	Modbus settings
Result	Determines whether the detected length is within the allowable range.	<input type="radio"/>
Fixed ROI	Displays the inspection area with alignment applied.	<input type="radio"/>
Intersection	Displays the intersection of the inspection area and the detected edge.	<input type="radio"/>
Detection Position	Displays the line formed by the detected edges.	-
Length	Outputs the detected length value.	<input type="radio"/>

Inspection result

Standard: 2100 to 2200

Pass

Length: 2157

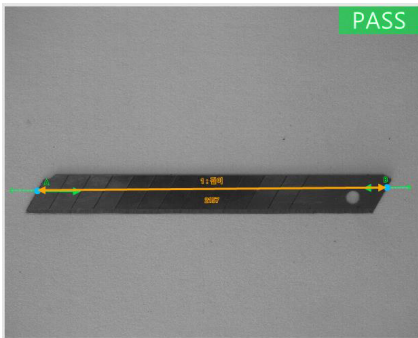

Fail

Length: 2012



3.5.3.7. Edge

The presence or absence of an edge is determined by comparing the angle of the detected edge in the ROI area set by the user.

Set the pass range based on the edge direction of the registered point.

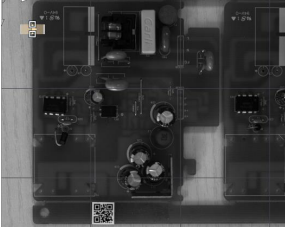
<p>01 Edge</p> <table border="1"> <tr> <td>Image</td> <td>Result</td> </tr> <tr> <td>Alignment</td> <td>Fixed ROI</td> </tr> <tr> <td>ROI</td> <td>Intersection</td> </tr> <tr> <td>Edge Threshold</td> <td>Detected Position</td> </tr> <tr> <td>Search Direction</td> <td>Angle</td> </tr> <tr> <td>Extraction Mode</td> <td></td> </tr> <tr> <td>Min Edge Angle</td> <td></td> </tr> <tr> <td>Max Edge Angle</td> <td></td> </tr> </table>	Image	Result	Alignment	Fixed ROI	ROI	Intersection	Edge Threshold	Detected Position	Search Direction	Angle	Extraction Mode		Min Edge Angle		Max Edge Angle		
Image	Result																
Alignment	Fixed ROI																
ROI	Intersection																
Edge Threshold	Detected Position																
Search Direction	Angle																
Extraction Mode																	
Min Edge Angle																	
Max Edge Angle																	

Input parameters

Name	Function	Modbus settings
Image	Set the input image.	-
Alignment	Enter a value to correct the position of the area of interest.	-
ROI	Set the inspection area. (refer to 3.3.5, "Path Fitting Field - Path")	-
Edge Threshold	Set the threshold for edge detection. If the threshold is high, only edges with sharp differences in brightness (high contrast) are detected, and when the threshold is low, edges with ambiguous differences in brightness (low contrast) are also detected.	○
Search Direction	Set the edge search direction of the area. - Bright area → Dark area: Searches from light to dark. - Dark area → Bright area: Searches from dark to light. - Any: Searches regardless of brightness.	-
Extraction Mode	Select the edge of the area. - Best: Selects the best edge. - First: Selects the first detected edge in the search direction. - Last: Selects the last detected edge in the search direction.	-
Min/Max Edge Angle	Set the minimum/maximum range of edge angles. - Setting range: 0 to 180	○

Output parameters

Name	Function	Modbus settings
Result	Determines whether the detected angle is within the allowable range.	○
Fixed ROI	Displays the inspection area with alignment applied.	Start point X, Y, end point X, Y
Intersection	Displays the intersection of the inspection area and the detected edge.	X, Y coordinates
Detection Position	Displays the line formed by the detected edges.	-
Angle	Outputs the angle formed by the detected edges.	○

Inspection result

Standard: 85 to 100

Pass

Edge Angle: 90.07



Fail

Edge Angle: 52.40



3.5.3.8. Object Counting

It measures the number of objects in the ROI area set by the user.

Since it is determined as one object only if it is more than a certain pixel, only the number of detected objects is determined without determining the similarity of the shape of the object.

01 Object Counting	
Image	Result
Alignment	Fixed ROI
ROI	Object
Min Area Size	Center Point
Extraction Mode	Perimeter
Binary Threshold	Brightness SD
Min Count	Circularity
Max Count	Size
	Count

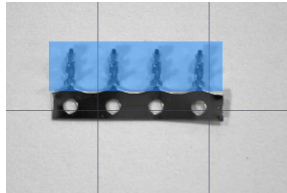

Input parameters

Name	Function	Modbus settings
Image	Set the input image.	-
Alignment	Enter a value to correct the position of the area of interest.	-
ROI	Set the inspection area. (refer to 3.3.3, "Region - Multiple shapes")	-
Min Area Size	Set the standard value for judging by area. If the number of pixels of an object detected by the binarization threshold is greater than the set value, it is recognized as one area and detected.	<input type="radio"/>
Detection Mode	Set the mode to extract the area. - Bright on Dark: Detects areas brighter than the background. - Dark on Bright: Detects areas darker than the background.	-
Binary Threshold	Set the threshold for image binarization. Measures the number of regions by converting 0 below the threshold to 1 and above the threshold.	<input type="radio"/>
Min/Max Count	Set the minimum/maximum range of the number of objects. - Setting range: 0 to 1320000	<input type="radio"/>

Output parameters

Name	Function	Modbus settings
Result	Determines whether the number of detected objects is within the allowable range.	○
Fixed ROI	Displays the inspection area with alignment applied.	-
Object	Displays the area of each object.	-
Center Point	Displays the center point of each object.	X, Y coordinates
Perimeter	Outputs the perimeter of each object.	○
Brightness SD	Outputs the brightness standard deviation of each object.	○
Circularity	Outputs the roundness of each object.	○
Size	Outputs the size of each object.	○
Count	Outputs the number of detected objects.	○

Inspection result

Standard: 4 to 4

Pass

Number of objects: 4

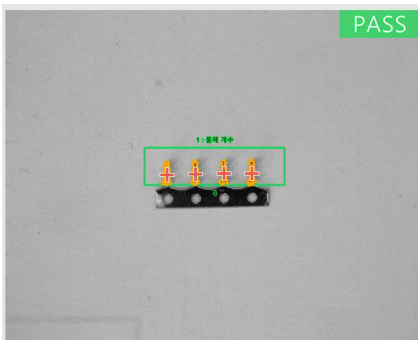

Fail

Number of objects: 3

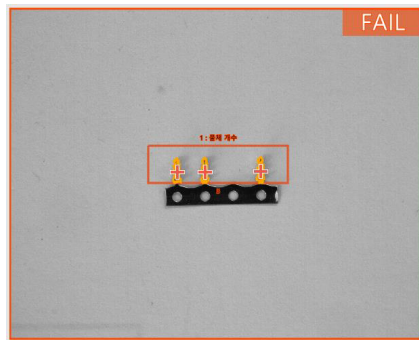

3.5.4. Matching

3.5.4.1. Shape Compare

It compares the shape model registered by the user with the detected edge of the input image to judge the loss rate of the shape.

Basic mode	Expert mode																											
<div style="border: 1px solid red; padding: 5px;"> <p>01 Shape Compare</p> <table border="1"> <tr><td>Image</td><td>Result</td></tr> <tr><td>Alignment</td><td>Fixed ROI</td></tr> <tr><td>Shape Model</td><td>Loss Region</td></tr> <tr><td>Edge Threshold</td><td>Loss Rate (%)</td></tr> <tr><td>Max Distance</td><td></td></tr> <tr><td>Loss Rate (%)</td><td></td></tr> </table> </div>	Image	Result	Alignment	Fixed ROI	Shape Model	Loss Region	Edge Threshold	Loss Rate (%)	Max Distance		Loss Rate (%)		<div style="border: 1px solid red; padding: 5px;"> <p>01 Shape Compare</p> <table border="1"> <tr><td>Image</td><td>Result</td></tr> <tr><td>Alignment</td><td>Fixed ROI</td></tr> <tr><td>Shape Model</td><td>Loss Region</td></tr> <tr><td>Smoothing</td><td>Loss Rate (%)</td></tr> <tr><td>Edge Threshold</td><td></td></tr> <tr><td>Max Distance</td><td></td></tr> <tr><td>Loss Rate (%)</td><td></td></tr> </table> </div>	Image	Result	Alignment	Fixed ROI	Shape Model	Loss Region	Smoothing	Loss Rate (%)	Edge Threshold		Max Distance		Loss Rate (%)		
Image	Result																											
Alignment	Fixed ROI																											
Shape Model	Loss Region																											
Edge Threshold	Loss Rate (%)																											
Max Distance																												
Loss Rate (%)																												
Image	Result																											
Alignment	Fixed ROI																											
Shape Model	Loss Region																											
Smoothing	Loss Rate (%)																											
Edge Threshold																												
Max Distance																												
Loss Rate (%)																												

Input parameters

Name	Function	Modbus settings
Image	Set the input image.	-
Alignment	Enter a value to correct the position of the area of interest.	-
Shape Model	Set the shape model (edge-based) of the object without defects. (refer to 3.4.3, "Geometry Model")	-
Smoothing	Set the smoothing intensity. If the image and brightness of the shape model are the same, set the same as the threshold value used when creating the model.	<input type="radio"/>
Edge Threshold	Set the threshold for edge detection. If the threshold is high, only edges with sharp differences in brightness (high contrast) are detected, and when the threshold is low, edges with ambiguous differences in brightness (low contrast) are also detected. If the image and brightness of the shape model are the same, set the same as the threshold value used when creating the model.	<input type="radio"/>
Max Distance	Set the maximum distance between the registered contour edge and the detected contour edge. If it is within the set distance, it is judged as the same edge and not included in the loss.	<input type="radio"/>
Loss Rate (%)	Set the maximum loss rate. If the checked loss rate is greater than the set value, a defect is output.	<input type="radio"/>

Output parameters

Name	Function	Modbus settings
Result	Determines whether the checked loss rate does not exceed the set loss rate range.	○
Fixed ROI	Displays the inspection area with alignment applied.	X,Y, angle, width, height
Loss Region	Displays the lost area.	-
Loss Rate (%)	Outputs the loss rate (%) of the detected shape compared to the registered shape.	○

Inspection result

Standard: 50

Pass

Loss rate: 0



Fail

Loss rate: 59.42



3.5.4.2. Shape Multi Compare (Edge)

Compares the shape (edge) registered by the user with the shape of the input image.

All shapes are detected based on the similarity rate with the registered shape.

01 Shape Multi Compare (Edge)	
Image	Result
Alignment	Fixed ROI
ROI	Detected Position
Edge Model	Similarity (%)
Edge Threshold	Count
Min Distance	
Similarity (%)	
Min Count	
Max Count	

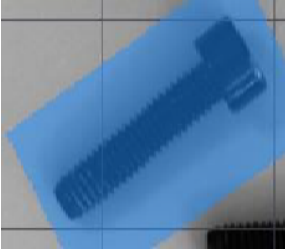

Input parameters

Name	Function	Modbus settings
Image	Set the input image.	-
Alignment	Enter a value to correct the position of the area of interest.	-
ROI	Set the inspection area. (refer to 3.3.3, “Region - Multiple shapes”)	-
Edge Model	Set the object’s shape model (edge-based). (refer to 3.4.1, “Edge Model”)	-
Edge Threshold	Set the threshold for edge detection. If the threshold is high, only edges with sharp differences in brightness (high contrast) are detected, and when the threshold is low, edges with ambiguous differences in brightness (low contrast) are also detected.	<input type="radio"/>
Min Distance	Set the minimum distance between features. It prevents recognizing the same shape multiple times.	<input type="radio"/>
Similarity (%)	Set the minimum similarity (%) between the registered shape and the detected shape.	<input type="radio"/>
Min/Max Count	Set the maximum/minimum value of the allowed range. - Setting range: 0 to 1320000	<input type="radio"/>

Output parameters

Name	Function	Modbus settings
Result	Determines whether the number of detected features is within the allowable range.	○
Fixed ROI	Displays the inspection area with alignment applied.	-
Detected Position	Displays the position of the detected shape.	X, Y, angle, width, height
Similarity (%)	Outputs each similarity (%) of the detected shape.	○
Count	Outputs the number of detected shapes.	○

Inspection result



Reference image

Standard similarity rate: 50, number of criteria: 2 to 3

Pass

Count: 2

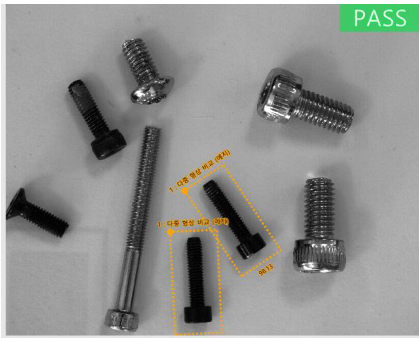

Fail

Count: 1

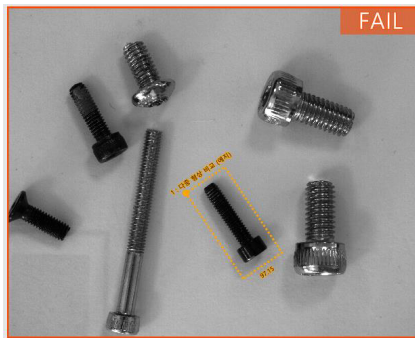

3.5.4.3. Shape Single Compare (Edge)

Compares the shape (edge) registered by the user with the shape of the input image. One shape with the highest similarity to the registered shape is detected.

01 Shape Single Compare (Edge)	
Image	Result
Alignment	Fixed ROI
ROI	Detected Position
Edge Model	Similarity (%)
Edge Threshold	
Similarity (%)	

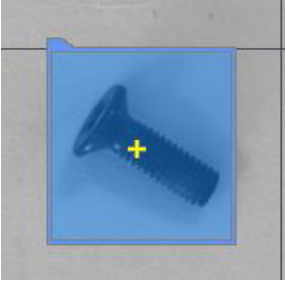

Input parameters

Name	Function	Modbus settings
Image	Set the input image.	-
Alignment	Enter a value to correct the position of the area of interest.	-
ROI	Set the inspection area. (refer to 3.3.3, “Region - Multiple shapes”)	-
Edge Model	Set the object’s geometric model (edge-based). (refer to 3.4.1, “Edge Model”)	-
Edge Threshold	Set the threshold for edge detection. If the threshold is high, only edges with sharp differences in brightness (high contrast) are detected, and when the threshold is low, edges with ambiguous differences in brightness (low contrast) are also detected.	<input type="radio"/>
Similarity (%)	Set the minimum similarity (%) between the registered shape and the detected shape.	<input type="radio"/>

Output parameters

Name	Function	Modbus settings
Result	Determine the presence or absence of shape.	<input type="radio"/>
Fixed ROI	Displays the inspection area with alignment applied.	-
Detected Position	Displays the position of the detected shape.	X, Y, angle, width, height
Similarity (%)	Outputs the similarity (%) between the registered shape and the input image.	<input type="radio"/>

Inspection result



Reference image

Standard: 55

Pass

Shape similarity rate: U, 99,75

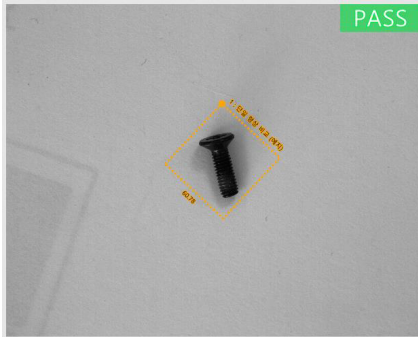

Fail

Shape similarity rate: None, bad shape



3.5.4.4. Shape Multi Compare (Pixel)

Compares the shape (pixels) registered by the user with the shape of the input image. All shapes are detected based on the similarity rate with the registered shape.

01 Shape Multi Compare (Pixel)	
Image	Result
Alignment	Fixed ROI
ROI	Detected Position
Pixel Model	Similarity (%)
Max Brightness Dev	Count
Min Distance	
Similarity (%)	
Min Count	
Max Count	

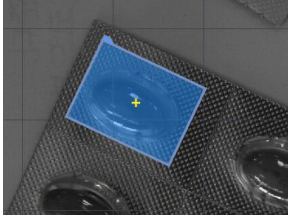

Input parameters

Name	Function	Modbus settings
Image	Set the input image.	-
Alignment	Enter a value to correct the position of the area of interest.	-
ROI	Set the inspection area. (refer to 3.3.3, “Region - Multiple shapes”)	-
Pixel Model	Set the object’s shape model (edge-based). (refer to 3.4.2, “Pixel Model”)	-
Max Brightness Dev	Set the maximum brightness deviation between the registered shape and the image. It is recognized as the same shape when the change in brightness is the same as it is smaller.	<input type="radio"/>
Min Distance	Set the minimum distance between features. It prevents recognizing the same shape multiple times.	<input type="radio"/>
Similarity (%)	Set the minimum similarity (%) between the registered shape and the detected shape.	<input type="radio"/>
Min/Max Count	Set the minimum/maximum values of the allowed range. - Setting range: 0 to 1320000	<input type="radio"/>

Output parameters

Name	Function	Modbus settings
Result	Determines whether the number of detected features is within the allowable range.	○
Fixed ROI	Displays the inspection area with alignment applied.	-
Detected Position	Displays the position of the detected shape.	X, Y, angle, width, height
Similarity (%)	Outputs each similarity (%) of the detected shape.	○
Count	Outputs the number of detected shapes.	○

Inspection result

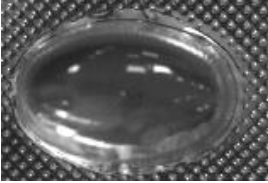

Reference image

Standard: 6

Pass

Number: 6



Fail

Count: 5

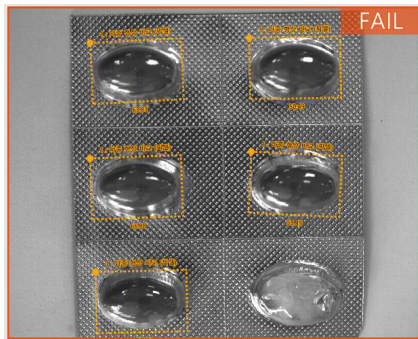

3.5.4.5. Shape Single Compare (Pixel)

Compares the shape (pixels) registered by the user with the shape of the input image. One shape with the highest similarity to the registered shape is detected.

01 Shape Single Compare (Pixel)	
Image	Result
Alignment	Fixed ROI
ROI	Detected Position
Pixel Model	Similarity (%)
Max Brightness Dev	
Similarity (%)	

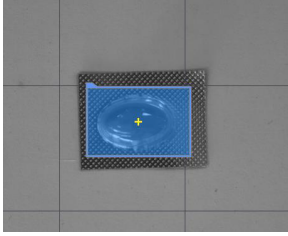

Input parameters

Name	Function	Modbus settings
Image	Set the input image.	-
Alignment	Enter a value to correct the position of the area of interest.	-s
ROI	Set the inspection area. (refer to 3.3.3, “Region - Multiple shapes”)	-
Pixel Model	Set the object’s geometric model (pixel-based). (refer to 3.4.2, “Pixel Model”)	-
Max Brightness Dev	Set the maximum brightness deviation between the registered shape and the image. It is recognized as the same shape when the change in brightness is the same as it is smaller.	<input type="radio"/>
Similarity (%)	Set the minimum similarity (%) between the registered shape and the detected shape.	<input type="radio"/>

Output parameters

Name	Function	Modbus settings
Result	Determines the presence or absence of shape.	<input type="radio"/>
Fixed ROI	Displays the inspection area with alignment applied.	-
Detection Position	Displays the position of the detected shape.	X, Y, angle, width, height
Similarity (%)	Outputs the similarity (%) between the registered shape and the input image.	<input type="radio"/>

Inspection result

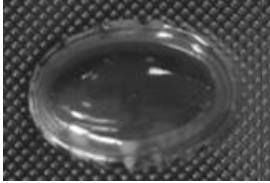

Reference image

Standard 70

Pass

Shape similarity : U, 90.06

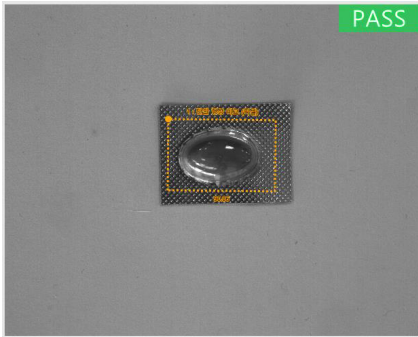

Fail

Shape similarity : None



3.5.5. Pre-Processing

3.5.5.1. Dilate

The value of the brightest pixel within the area replaces that pixel.
Removes dark noise from bright images.

01 Dilate	
Image	Result Image
ROI	
Area Size	

Input parameters

Name	Function	Modbus settings
Image	Set the input image.	-
ROI	Set the inspection area. (refer to 3.3.3, "Region - Multiple shapes")	-
Area Size	Set the size of the dilated area.	○

Output parameters

Name	Function	Modbus settings
Result Image	Outputs the result image.	-

Setting result

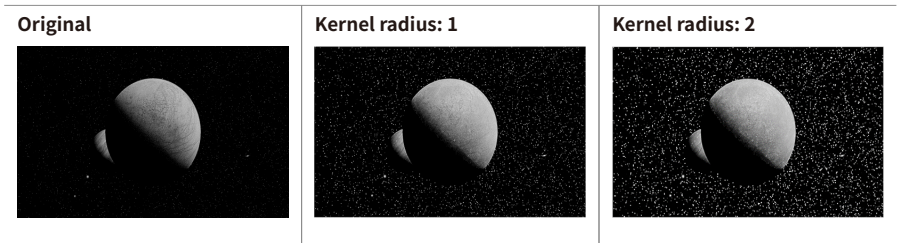

3.5.5.2. Erode

The smallest of the pixels in the kernel becomes the value of the output pixel, reducing part of the image.

It is for the bright noise in a dark image.

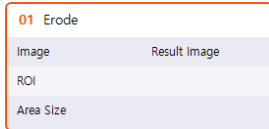

Input parameters

Name	Function	Modbus settings
Image	Set the input image.	-
ROI	Set the inspection area. (refer to 3.3.3, "Region - Multiple shapes")	-
Area Size	Set the size of the erosion area.	<input type="radio"/>

Output parameters

Name	Function	Modbus settings
Result Image	Outputs the result image.	-

Setting result

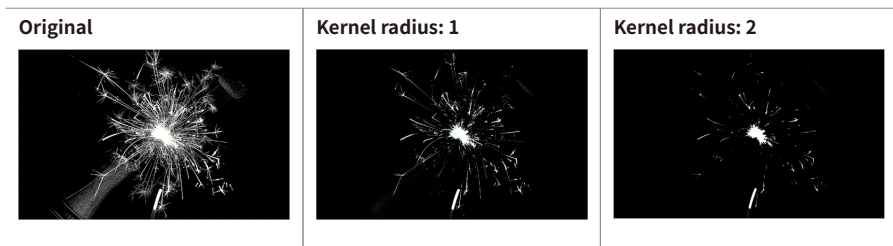

3.5.5.3. Equalize Histogram

Rebalances the distribution of pixel values and improves the contrast of the image.

This operation is used when the distribution of the light and dark values is skewed to one side or the image is not uniform. It improves the quality of the image by equalizing the distribution of the light and dark values.

Basic mode	Advanced Mode
<div style="border: 1px solid red; padding: 5px;"> <p>01 Equalize Histogram</p> <p>Image Result Image</p> <p>ROI</p> </div>	<div style="border: 1px solid red; padding: 5px;"> <p>01 Equalize Histogram</p> <p>Image Result Image</p> <p>ROI</p> <p>Brightest Adjustment</p> <p>Darkest Adjustment</p> </div>

Input parameters

Name	Function	Modbus settings
Image	Set the input image.	-
ROI	Set the inspection area. (refer to 3.3.3, "Region - Multiple shapes")	-
Brightest Adjustment	Set the portion of the brightest pixel to be excluded (%). A setting of 0.1 is smooth out the 10% of the brightest pixels during smoothing.	<input type="radio"/>
Darkest Adjustment	Set the portion of the darkest pixel to be excluded (%). A setting of 0.1 is smooth out the 10% of the brightest pixels during smoothing.	<input type="radio"/>

Output parameters

Name	Function	Modbus settings
Result Image	Outputs the result image.	-

Setting result



Original image

Lights: 0.2, Darks: 0.1



Lights: 0.4, Darks: 0.1



Lights: 0.1, Darks: 0.3



3.5.5.4. Gamma Correction

Performs gamma correction of the image to compensate for the non-linear output generated by the image sensor.

01 Gamma Correction	
Image	Result Image
ROI	
Gamma Factor	

Input parameters

Name	Function	Modbus settings
Image	Set the input image.	-
ROI	Set the inspection area. (refer to 3.3.3, "Region - Multiple shapes")	-
Gamma Factor	Set the gamma factor.	○

Output parameters

Name	Function	Modbus settings
Result Image	Outputs the result image.	-

Setting result



Original image

Gamma factor: 1



Gamma factor: 0.5



Gamma factor: 0.3



3.5.5.5. Invert Image

Inverts the brightness of the image.

01 Invert Image	
Image	Result Image
ROI	

Input parameters

Name	Function	Modbus settings
Image	Set the input image.	-
ROI	Set the inspection area. (refer to 3.3.3, “Region - Multiple shapes”)	-

Output parameters

Name	Function	Modbus settings
Result Image	Outputs the result image.	-

Setting result

Original



Invert image



3.5.5.6. Change Brightness

Adjusts the brightness of the image by exponentiating the input value for each pixel.

If the image is too dark or too bright, the input value adjusts the overall image brightness.

The input values are used to index each pixel in the image.

01 Change Brightness	
Image	Result Image
ROI	
Brightness Value	



Input parameters

Name	Function	Modbus settings
Image	Set the input image.	-
ROI	Set the inspection area. (refer to 3.3.3, "Region - Multiple shapes")	-
Brightness Value	Set the value for brightness change.	○

Output parameters

Name	Function	Modbus settings
Result Image	Outputs the result image.	-

Setting result

Original	Brightness Value: 1	Brightness Value: 3
		

3.5.5.7. Normalize Image

Adjusts the brightness min/max values to correct the brightness of the image.

Basic mode	Advanced Mode																				
<div style="border: 1px solid red; padding: 5px;"> <p>01 Normalize Image</p> <table border="1"> <tr> <td>Image</td> <td>Result Image</td> </tr> <tr> <td>ROI</td> <td></td> </tr> <tr> <td>New Min Brightness</td> <td></td> </tr> <tr> <td>New Max Brightness</td> <td></td> </tr> </table> </div>	Image	Result Image	ROI		New Min Brightness		New Max Brightness		<div style="border: 1px solid red; padding: 5px;"> <p>01 Normalize Image</p> <table border="1"> <tr> <td>Image</td> <td>Result Image</td> </tr> <tr> <td>ROI</td> <td></td> </tr> <tr> <td>New Min Brightness</td> <td></td> </tr> <tr> <td>New Max Brightness</td> <td></td> </tr> <tr> <td>Brightest Adjustment</td> <td></td> </tr> <tr> <td>Darkest Adjustment</td> <td></td> </tr> </table> </div>	Image	Result Image	ROI		New Min Brightness		New Max Brightness		Brightest Adjustment		Darkest Adjustment	
Image	Result Image																				
ROI																					
New Min Brightness																					
New Max Brightness																					
Image	Result Image																				
ROI																					
New Min Brightness																					
New Max Brightness																					
Brightest Adjustment																					
Darkest Adjustment																					

Input parameters

Name	Function	Modbus settings
Image	Set the input image.	-
ROI	Set the inspection area. (refer to 3.3.3, “Region - Multiple shapes”)	-
New Min Brightness	Set the minimum brightness value of the output image. If the pixel intensity value is less than the minimum value, it is changed to the minimum value.	<input type="radio"/>
New Max Brightness	Set the maximum brightness value of the output image. If the pixel intensity value is greater than the maximum value, it is changed to the maximum value.	<input type="radio"/>
Brightest Adjustment	Set the portion of the brightest pixel to be excluded (%). A setting of 0.1 is smooth out the 10% of the brightest pixels during smoothing. Proceed.	<input type="radio"/>
Darkest Adjustment	Set the portion of the darkest pixel to be excluded (%). A setting of 0.1 is smooth out the 10% of the brightest pixels during smoothing. Proceed.	<input type="radio"/>

Output parameters

Name	Function	Modbus settings
Result Image	Outputs the result image.	-

Setting result

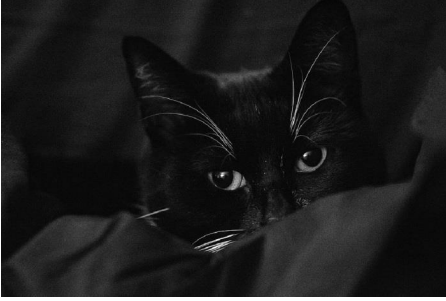

Original image

Maximum value: 200

Light: 0.2, Dark: 0.1



Maximum value: 200

Light: 0.4, Dark: 0.1



Maximum value: 200

Light: 0.4, Dark: 0.6



3.5.5.8. Sharpen

Enhances the contrast of an image to make it look sharp.

01 Sharpen

Image	Result Image
Sharpness	

Input parameters

Name	Function	Modbus settings
Image	Set the input image.	-
Sharpness	Set the sharpness.	○

Output parameters

Name	Function	Modbus settings
Result Image	Outputs the result image.	-

Setting result



Original image

Sharpness: 1.3



Sharpness: 1.5

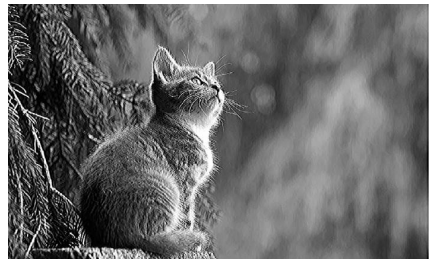

3.5.5.9. Smoothing

Smooths the image by convolution of the image and the Gaussian kernel.

01 Smooth

Image	Result Image
ROI	
Smoothing	

Input parameters

Name	Function	Modbus settings
Image	Set the input image.	-
ROI	Set the inspection area. (refer to 3.3.3, "Region - Multiple shapes")	-
Smoothing g	Set the smoothing strength. The higher the value, the softer the image.	○

Output parameters

Name	Function	Modbus settings
Result Image	Outputs the result image.	-

Original	Smoothing: 4	Smoothing: 8
		

3.5.5.10. Median

The intermediate pixel value within the setting area replaces that pixel.
It is effective in removing noise.

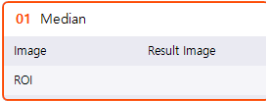

Input parameters

Name	Function	Modbus settings
Image	Set the input image.	-
ROI	Set the inspection area. (refer to 3.3.3, “Region - Multiple shapes”)	-

Output parameters

Name	Function	Modbus settings
Result Image	Outputs the result image.	-

Setting result

Original



Median applied



3.5.6. Data-Processing

3.5.6.1. Arithmetic

Calculation results are output by applying arithmetic equation symbols to multiple inspection result values.

Only float data can be used as an input value,

and integer data can be connected as an input value after 3.5.6.4, “Integer to Float”.

01	A+B-C*10
A	Result
B	
C	

Arithmetic Equation Symbol

+, -, *, /

How to set

1. Add the arithmetic check function to the check editor.
2. When the formula input window opens as shown below, enter the arithmetic formula.
Ex) $A + B - C * 10$

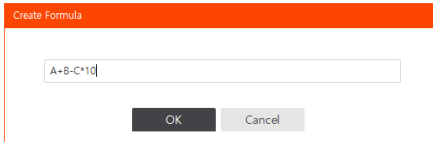

Create Formula

A+B-C*10

OK Cancel

3. If you connect the input registered as text with another filter, the formula is calculated.

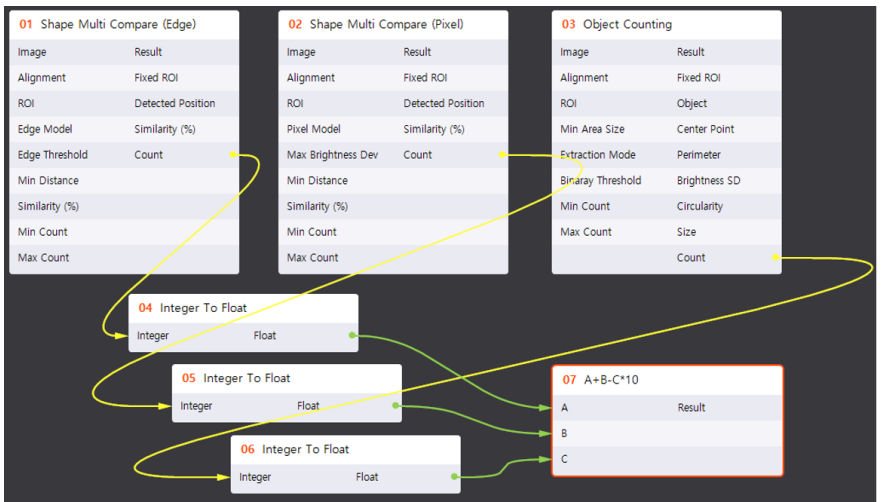

3.5.6.2. Conditional Comparison

Pass/Fail is judged by creating a condition in which the inequality sign is applied to multiple test result values.

Only float data can be used as an input value,

and integer data can be connected as an input value after 3.5.6.4, “Integer to Float”.

01 a>b	
a	Result
b	

Inequality Sign Modifier

<, >, <=, >=, !=, ==

How to set

1. Add the conditional comparison check feature to the check editor.
2. Enter the inequality sign in the formula input window as shown below.

Ex) $a > b$

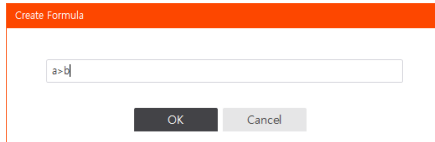

Create Formula

a>b

OK Cancel

3. If the input registered as text is connected with another filter, the condition is judged.

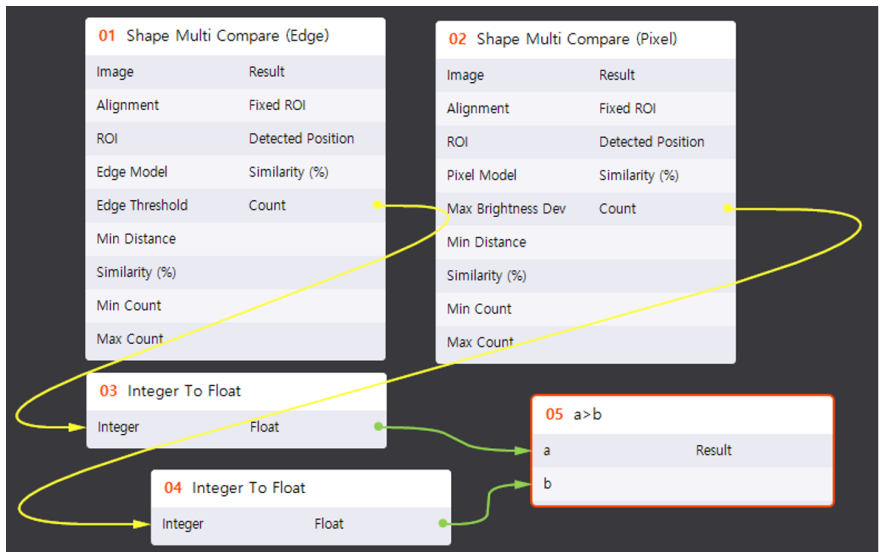

3.5.6.3. Float to Integer

Converts a float variable to an integer.

01 Float To Integer	
Float	Integer

Input parameters

Name	Function	Modbus settings
Float	Enter the decimal to convert.	<input type="radio"/>

Output parameters

Name	Function	Modbus settings
Integer	Outputs the converted integer value.	<input type="radio"/>

3.5.6.4. Integer to Float

Converts an integer variable to a float .

01 Integer To Float	
Integer	Float

Input parameters

Name	Function	Modbus settings
Integer	Enter the integer to convert.	<input type="radio"/>

Output parameters

Name	Function	Modbus settings
Float	Outputs the converted decimal value.	<input type="radio"/>

3.5.6.5. Rectangle Attribute

Converts rectangle values to X, Y, angle, width, and height values.

01 Rectangle Attribute	
Rectangle	X Position
	Y Position
	Angle
	Width
	Height

Input parameters

Name	Function	Modbus settings
Rectangle	Enter the decimal to convert.	<input type="radio"/>

Output parameters

Name	Function	Modbus settings
X Position	Outputs the X coordinate of the origin.	<input type="radio"/>
Y Position	Outputs the Y coordinate of the origin.	<input type="radio"/>
Angle	Outputs the rotation angle with respect to the origin.	<input type="radio"/>
Width	Outputs the width.	<input type="radio"/>
Height	Outputs the height.	<input type="radio"/>

3.5.6.6. Create Rectangle

Creates a rectangle using X, Y, angle, width, and height.

01 Create Rectangle	
X Position	Rectangle Area
Y Position	
Angle	
Width	
Height	

Input parameters

Name	Function	Modbus settings
X Position	Set the X coordinate of the origin.	<input type="radio"/>
Y Position	Set the Y coordinate of the origin.	<input type="radio"/>
Angle	Set the rotation angle with respect to the origin.	<input type="radio"/>
Width	Set the width.	<input type="radio"/>
Height	Set the height.	<input type="radio"/>

Output parameters

Name	Function	Modbus settings
Rectangle	Area Outputs the generated rectangle.	X, Y, angle, width, height

3.5.6.7. Create Edge Detect Area

Creates an edge detection area using start point X, start point Y, end point X, and end point Y.

01 Create Edge Detect Area	
Start X Position	Edge Detection Area
Start Y Position	
End X Position	
End Y Position	

Input parameters

Name	Function	Modbus settings
Start X Position	Set the start point X position of the edge detection area.	<input type="radio"/>
Start Y Position	Set the start point Y position of the edge detection area.	<input type="radio"/>
End X Position	Set the end point X position of the edge detection area.	<input type="radio"/>
End Y Position	Set the end point Y position of the edge detection area.	<input type="radio"/>

Output parameters

Name	Function	Modbus settings
Edge Detection Area	Outputs the generated edge detection area.	Start point X, start point Y, end point X, end point Y

3.5.6.8. Create Line Detect Area

Creates a circle detection area using start point X, start point Y, end point X, end point Y, and width.

01 Create Line Detect Area

Start X Position	Line Detection Area
Start Y Position	
End X Position	
End Y Position	
Width	

Input parameters

Name	Function	Modbus settings
Start X Position	Set the start point X position of the line detection area.	<input type="radio"/>
Start Y Position	Set the start point Y position of the line detection area.	<input type="radio"/>
End X Position	Set the end point X position of the line detection area.	<input type="radio"/>
End Y Position	Set the end point Y position of the line detection area.	<input type="radio"/>
Width	Set the width of the line detection area.	<input type="radio"/>

Output parameters

Name	Function	Modbus settings
Line Detection Area	Outputs the generated line detection area.	Start point X, start point Y, end point X, end point Y, width

The detection direction is set to the right vertical direction when looking from the start point to the end point.

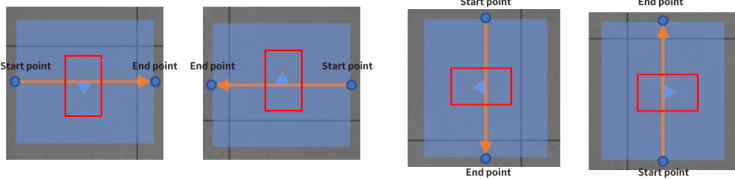

3.5.6.9. Create Circle Detect Area

Creates a circle detection area using center point X, center point Y, radius, and width.

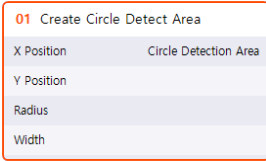

Input parameters

Name	Function	Modbus settings
X Position	Set the X coordinate of the circle's center point.	<input type="radio"/>
Y Position	Set the Y coordinate of the circle's center point.	<input type="radio"/>
Radius	Set the radius of the circle.	<input type="radio"/>
Width	Set the width of the detection area of the circle.	<input type="radio"/>

Output parameters

Name	Function	Modbus settings
Circle Detection Area	Outputs the generated circle detection area.	X, Y, radius, width

4. Modbus List

4.1. Input

Work_Input	Data type	Data size	Modbus mapping size	Note
Device_Capture Trigger	bool	1 bit	1 word	1 operates by entering [DEC]
Device_WorkGroup Change	Int	4 byte	2 word	displays operating work group number / operates by entering changed work group number
Alignment_Edge Threshold	float	4 byte	2 word	
Alignment_Similarity (%)	float	4 byte	2 word	
Barcode_ROI X	float	4 byte	2 word	
Barcode_ROI Y	float	4 byte	2 word	
Barcode_ROI angle	float	4 byte	2 word	
Barcode_ROI width	float	4 byte	2 word	
Barcode_ROI height	float	4 byte	2 word	
Barcode_Base Bar Width	int	4 byte	2 word	
Barcode_Scan Width	int	4 byte	2 word	
Barcode_Edge Threshold	float	4 byte	2 word	
Data Matrix_ROI X	float	4 byte	2 word	
Data Matrix_ROI Y	float	4 byte	2 word	

Work_Input	Data type	Data size	Modbus mapping size	Note
Data Matrix_ROI angle	float	4 byte	2 word	
Data Matrix_ROI width	float	4 byte	2 word	
Data Matrix_ROI height	float	4 byte	2 word	
Data Matrix_Edge Threshold	int	4 byte	2 word	
Data Matrix_Max Row Count	int	4 byte	2 word	
Data Matrix_Max Column Count	int	4 byte	2 word	
QR_ROI X	float	4 byte	2 word	
QR_ROI Y	float	4 byte	2 word	
QR_ROI angle	float	4 byte	2 word	
QR_ROI width	float	4 byte	2 word	
QR_ROI height	float	4 byte	2 word	
QR_Min Cell Size	float	4 byte	2 word	
QR_Edge Threshold	float	4 byte	2 word	
Extract Character_ROI X	float	4 byte	2 word	
Extract Character_ROI Y	float	4 byte	2 word	
Extract Character_ROI angle	float	4 byte	2 word	
Extract Character_ROI width	float	4 byte	2 word	

Work_Input	Data type	Data size	Modbus mapping size	Note
Extract Character_ROI height	float	4 byte	2 word	
Read Character_Target Character	string	128 byte	64 word	
Read Character_Target Character (%)	float	4 byte	2 word	
Area_Binary Threshold	float	4 byte	2 word	
Area_Min Area	int	4 byte	2 word	
Area_Max Area	int	4 byte	2 word	
Angle_A ROI Start Point X	float	4 byte	2 word	
Angle_A ROI Start Point Y	float	4 byte	2 word	
Angle_A ROI end X	float	4 byte	2 word	
Angle_A ROI end Y	float	4 byte	2 word	
Angle_A ROI width	float	4 byte	2 word	
Angle_A Edge Threshold	float	4 byte	2 word	
Angle_B ROI Start Point X	float	4 byte	2 word	
Angle_B ROI Start Point Y	float	4 byte	2 word	
Angle_B ROI End Point X	float	4 byte	2 word	
Angle_B ROI End Point Y	float	4 byte	2 word	
Angle_B ROI width	float	4 byte	2 word	

Work_Input	Data type	Data size	Modbus mapping size	Note
Angle_B Edge Threshold	float	4 byte	2 word	
Angle_Min Angle	float	4 byte	2 word	
Angle_Max Angle	float	4 byte	2 word	
Brightness_Min Brightness	float	4 byte	2 word	
Brightness_Max Brightness	float	4 byte	2 word	
Contrast_Min Contrast	float	4 byte	2 word	
Contrast_Max Contrast	float	4 byte	2 word	
Diameter_ROI X	float	4 byte	2 word	
Diameter_ROI Y	float	4 byte	2 word	
Diameter_ROI Radius	float	4 byte	2 word	
Diameter_ROI width	float	4 byte	2 word	
Diameter_Scan Width	int	4 byte	2 word	
Diameter_Scan Count	int	4 byte	2 word	
Diameter_Edge Threshold	float	4 byte	2 word	
Diameter_Min Diameter	int	4 byte	2 word	
Diameter_Max Diameter	int	4 byte	2 word	
Length_A ROI Start Point X	float	4 byte	2 word	

Work_Input	Data type	Data size	Modbus mapping size	Note
Length_A ROI Start Point Y	float	4 byte	2 word	
Length_A ROI End Point X	float	4 byte	2 word	
Length_A ROI End Point Y	float	4 byte	2 word	
Length_A Edge Threshold	float	4 byte	2 word	
Length_B ROI Start Point X	float	4 byte	2 word	
Length_B ROI Start Point Y	float	4 byte	2 word	
Length_B ROI End Point X	float	4 byte	2 word	
Length_B ROI End Point Y	float	4 byte	2 word	
Length_B Edge Threshold	float	4 byte	2 word	
Length_Min Length	int	4 byte	2 word	
Length_Max Length	int	4 byte	2 word	
Edge_Edge Threshold	float	4 byte	2 word	
Edge_Min Edge Angle	float	4 byte	2 word	
Edge_Max Edge Angle	float	4 byte	2 word	
Object Counting_Min Area Size	int	4 byte	2 word	
Object Counting_Binary Threshold	float	4 byte	2 word	
Object Counting_Min Count	int	4 byte	2 word	

Work_Input	Data type	Data size	Modbus mapping size	Note
Object Counting_Max Count	int	4 byte	2 word	
Shape Compare_Smoothing	float	4 byte	2 word	
Shape Compare_Edge Threshold	float	4 byte	2 word	
Shape Compare_Max Distance	int	4 byte	2 word	
Shape Compare_Loss Rate (%)	float	4 byte	2 word	
Shape Multi Compare (Edge)_Edge Threshold	float	4 byte	2 word	
Shape Multi Compare (Edge)_Min Distance	float	4 byte	2 word	
Shape Multi Compare (Edge)_Similarity (%)	float	4 byte	2 word	
Shape Multi Compare (Edge)_Min Count	int	4 byte	2 word	
Shape Multi Compare (Edge)_Max Count	int	4 byte	2 word	
Shape Single Compare (Edge)_Edge Threshold	float	4 byte	2 word	
Shape Single Compare (Edge)_Similarity (%)	float	4 byte	2 word	
Shape Multi Compare (Pixel)_Max Brightness Dev	float	4 byte	2 word	
Shape Multi Compare (Pixel)_Min Distance	float	4 byte	2 word	
Shape Multi Compare (Pixel)_Similarity (%)	float	4 byte	2 word	
Shape Multi Compare (Pixel)_Min Count	int	4 byte	2 word	
Shape Multi Compare (Pixel)_Max Count	int	4 byte	2 word	

Work_Input	Data type	Data size	Modbus mapping size	Note
Shape Single Compare (Pixel)_Max Brightness Dev	float	4 byte	2 word	
Shape Single Compare (Pixel)_Similarity (%)	float	4 byte	2 word	
Dilate_Area Size	int	4 byte	2 word	
Erode_Area Size	int	4 byte	2 word	
Equalize Histogram_Brightest Adjustment	float	4 byte	2 word	
Equalize Histogram_Darkest Adjustment	float	4 byte	2 word	
Gamma Correction_Gamma Factor	float	4 byte	2 word	
Change Brightness_Brightness Value	float	4 byte	2 word	
Normalize Image_New Min Brightness	float	4 byte	2 word	
Normalize Image_New Max Brightness	float	4 byte	2 word	
Normalize Image_Brightest Adjustment	float	4 byte	2 word	
Normalize Image_Darkest Adjustment	float	4 byte	2 word	
Sharpen_Sharpeness	float	4 byte	2 word	
Smoothing_Smoothing	float	4 byte	2 word	

Work_Input	Data type	Data size	Modbus mapping size	Note
Float to Integer_Float	float	4 byte	2 word	
Integer to Float_Integer	int	4 byte	2 word	
Rectangle Attribute_Rectangle X	float	4 byte	2 word	
Rectangle Attribute_Rectangle Y	float	4 byte	2 word	
Rectangle Attribute_Rectangle Angle	float	4 byte	2 word	
Rectangle Attribute_Rectangle Width	float	4 byte	2 word	
Rectangle Attribute_Rectangle Height	float	4 byte	2 word	
Create Rectangle_X Position	int	4 byte	2 word	
Create Rectangle_Y Position	int	4 byte	2 word	
Create Rectangle_Angle	float	4 byte	2 word	
Create Rectangle_Width	int	4 byte	2 word	
Create Rectangle_Height	int	4 byte	2 word	
Create Edge Detect Area_Start Point X Position	int	4 byte	2 word	
Create Edge Detect Area_Start Point Y Position	int	4 byte	2 word	
Create Edge Detect Area_End Point X Position	int	4 byte	2 word	

Work_Input	Data type	Data size	Modbus mapping size	Note
Create Edge Detect Area_End Point Y Position	int	4 byte	2 word	
Create Line Detect Area_Start Point X Position	int	4 byte	2 word	
Create Line Detect Area_Start Point Y Position	int	4 byte	2 word	
Create Line Detect Area_End Point X Position	int	4 byte	2 word	
Create Line Detect Area_End Point Y Position	int	4 byte	2 word	
Create Line Detect Area_Width	int	4 byte	2 word	
Create Circle Detect area_X Position	int	4 byte	2 word	
Create Circle Detect area_Y Position	int	4 byte	2 word	
Create Circle Detect area_Radius	float	4 byte	2 word	
Create Circle Detect area_Width	float	4 byte	2 word	

4.2. Output

Work_Input	Data type	Data size	Modbus mapping size	Note
Device_Inspection Complete	bool	1 bit	1 word	Under inspection: 0 [DEC] / Complete inspection: 1 [DEC]
Device_Inspection Pass	bool	1 bit	1 word	Under inspection: 0 [DEC] / Inspection PASS: 1 [DEC]
Device_Inspection Fail	bool	1 bit	1 word	Under inspection: 0 [DEC] / Inspection FAIL: 1 [DEC]
Device_Alarm	int	4 byte	2 word	0 BIT: Tigger Input Error / 1 BIT: Over Inspection Time / 3 BIT: FTP Transmission Error
Device_WorkGroup Change Check	int	4 byte	2 word	Under working: 0 [DEC] (h0000) / Change Fail: -1 [DEC] (hFFFF) / Change Success: Operating Work Group Number
Alignment_Result	bool	1 bit	1 word	
Alignment_Detected Position X	float	4 byte	2 word	
Alignment_Detected Position Y	float	4 byte	2 word	
Alignment_Detected Position Angle	float	4 byte	2 word	
Alignment_Detected Position Width	float	4 byte	2 word	
Alignment_Detected Position Height	float	4 byte	2 word	
Alignment_Similarity (%)	float	4 byte	2 word	
Alignment_Center Point X	float	4 byte	2 word	
Alignment_Center Point Y	float	4 byte	2 word	
Barcode_Result	bool	1 bit	1 word	
Barcode_Fixed ROI X	float	4 byte	2 word	
Barcode_Fixed ROI Y	float	4 byte	2 word	

Work_Input	Data type	Data size	Modbus mapping size	Note
Barcode_Fixed ROI Angle	float	4 byte	2 word	
Barcode_Fixed ROI Width	float	4 byte	2 word	
Barcode_Fixed ROI Height	float	4 byte	2 word	
Barcode_Read Code	string	128 byte	64 word	
Data Matrix_Result	bool	1 bit	1 word	
Data Matrix_Fixed ROI X	float	4 byte	2 word	
Data Matrix_Fixed ROI Y	float	4 byte	2 word	
Data Matrix_Fixed ROI Angle	float	4 byte	2 word	
Data Matrix_Fixed ROI Width	float	4 byte	2 word	
Data Matrix_Fixed ROI Height	float	4 byte	2 word	
Data Matrix_Read Code	string	128 byte	64 word	
QR_Result	bool	1 bit	1 word	
QR_Fixed ROI X	float	4 byte	2 word	
QR_Fixed ROI Y	float	4 byte	2 word	
QR_Fixed ROI Angle	float	4 byte	2 word	
QR_Fixed ROI Width	float	4 byte	2 word	
QR_Fixed ROI Height	float	4 byte	2 word	
QR_Read Code	string	128 byte	64 word	
Extract Character_Result	bool	1 bit	1 word	

Work_Input	Data type	Data size	Modbus mapping size	Note
Extract Character_Fixed ROI X	float	4 byte	2 word	
Extract Character_Fixed ROI Y	float	4 byte	2 word	
Extract Character_Fixed ROI Angle	float	4 byte	2 word	
Extract Character_Fixed ROI Width	float	4 byte	2 word	
Extract Character_Fixed ROI Height	float	4 byte	2 word	
Read Character_Result	bool	1 bit	1 word	
Read Character_Fixed ROI X	float	4 byte	2 word	Up to 10 multi-data can be transmitted ^[1]
Read Character_Fixed ROI Y	float	4 byte	2 word	Up to 10 multi-data can be transmitted ^[1]
Read Character_Fixed ROI Angle	float	4 byte	2 word	Up to 10 multi-data can be transmitted ^[1]
Read Character_Fixed ROI Width	float	4 byte	2 word	Up to 10 multi-data can be transmitted ^[1]
Read Character_Fixed ROI Height	float	4 byte	2 word	Up to 10 multi-data can be transmitted ^[1]
Read Character_Detection Sensitivity (%)	float	4 byte	2 word	Up to 10 multi-data can be transmitted ^[1]
Read Character_Read Character	string	128 byte	64 word	
Area_Result	bool	1 bit	1 word	
Area_Area Size	int	4 byte	2 word	
Angle_Result	bool	1 bit	1 word	
Angle_Fixed ROI 0 Start Point X	float	4 byte	2 word	
Angle_Fixed ROI 0 Start Point Y	float	4 byte	2 word	

Work_Input	Data type	Data size	Modbus mapping size	Note
Angle_Fixed ROI 0 End Point X	float	4 byte	2 word	
Angle_Fixed ROI 0 End Point Y	float	4 byte	2 word	
Angle_Fixed ROI 1 Start Point X	float	4 byte	2 word	
Angle_Fixed ROI 1 Start Point Y	float	4 byte	2 word	
Angle_Fixed ROI 1 End Point X	float	4 byte	2 word	
Angle_Fixed ROI 1 End Point Y	float	4 byte	2 word	
Angle_Intersection 0 X	float	4 byte	2 word	
Angle_Intersection 0 Y	float	4 byte	2 word	
Angle_Intersection 1 X	float	4 byte	2 word	
Angle_Intersection 1 Y	float	4 byte	2 word	
Angle	float	4 byte	2 word	
Brightness_Result	bool	4 byte	2 word	
Brightness	float	4 byte	2 word	
Contrast_Result	bool	1 bit	1 word	
Contrast	float	4 byte	2 word	
Diameter_Result	bool	1 bit	1 word	
Diameter_Fixed ROI Start Point X	float	4 byte	2 word	Up to 10 multi-data can be transmitted ^[1]
Diameter_Fixed ROI Start Point Y	float	4 byte	2 word	Up to 10 multi-data can be transmitted ^[1]

Work_Input	Data type	Data size	Modbus mapping size	Note
Diameter_Fixed ROI End Point X	float	4 byte	2 word	Up to 10 multi-data can be transmitted ^[1]
Diameter_Fixed ROI End Point Y	float	4 byte	2 word	Up to 10 multi-data can be transmitted ^[1]
Diameter_Circle Status	bool	1 bit	1 word	
Diameter_Edge Position X	float	4 byte	2 word	
Diameter_Edge Position Y	float	4 byte	2 word	
Diameter_Circle X	float	4 byte	2 word	
Diameter_Circle Y	float	4 byte	2 word	
Diameter_Circle Radius	float	4 byte	2 word	
Diameter	int	4 byte	2 word	
Length_Result	bool	1 bit	1 word	
Length_Fixed ROI 0	float	4 byte	2 word	
Length_Fixed ROI 0	float	4 byte	2 word	
Length_Fixed ROI 0	float	4 byte	2 word	
Length_Fixed ROI 0	float	4 byte	2 word	
Length_Fixed ROI 1	float	4 byte	2 word	
Length_Fixed ROI 1	float	4 byte	2 word	
Length_Fixed ROI 1	float	4 byte	2 word	
Length_Fixed ROI 1	float	4 byte	2 word	

Work_Input	Data type	Data size	Modbus mapping size	Note
Length_Intersection 0 X	float	4 byte	2 word	
Length_Intersection 0 Y	float	4 byte	2 word	
Length_Intersection 1 X	float	4 byte	2 word	
Length_Intersection 1 Y	float	4 byte	2 word	
Length	int	4 byte	2 word	
Edge_Result	bool	1 bit	1 word	
Edge_Fixed ROI Start Point X	float	4 byte	2 word	Up to 10 multi-data can be transmitted ^[1]
Edge_Fixed ROI Start Point Y	float	4 byte	2 word	Up to 10 multi-data can be transmitted ^[1]
Edge_Fixed ROI End Point X	float	4 byte	2 word	Up to 10 multi-data can be transmitted ^[1]
Edge_Fixed ROI End Point Y	float	4 byte	2 word	Up to 10 multi-data can be transmitted ^[1]
Edge_Intersection X	float	4 byte	2 word	Up to 10 multi-data can be transmitted ^[1]
Edge_Intersection Y	float	4 byte	2 word	Up to 10 multi-data can be transmitted ^[1]
Edge_Angle	float	4 byte	2 word	
Object Counting_Result	bool	1 bit	1 word	
Object Counting_Center Point X	float	4 byte	2 word	Up to 10 multi-data can be transmitted ^[1]
Object Counting_Center Point Y	float	4 byte	2 word	Up to 10 multi-data can be transmitted ^[1]
Object Counting_Perimeter	float	4 byte	2 word	Up to 10 multi-data can be transmitted ^[1]
Object Counting_Brightness SD	float	4 byte	2 word	Up to 10 multi-data can be transmitted ^[1]

Work_Input	Data type	Data size	Modbus mapping size	Note
Object Counting_Circularity	float	4 byte	2 word	Up to 10 multi-data can be transmitted ^[1]
Object Counting_Size	float	4 byte	2 word	Up to 10 multi-data can be transmitted ^[1]
Object Counting_Count	int	4 byte	2 word	
Shape Compare_Result	bool	1 bit	1 word	
Shape Compare_Fixed ROI X	float	4 byte	2 word	
Shape Compare_Fixed ROI Y	float	4 byte	2 word	
Shape Compare_Fixed ROI Angle	float	4 byte	2 word	
Shape Compare_Fixed ROI Width	float	4 byte	2 word	
Shape Compare_Fixed ROI Height	float	4 byte	2 word	
Shape Compare_Loss Rate (%)	float	4 byte	2 word	
Shape Multi Compare (Edge)_Result	bool	4 byte	2 word	
Shape Multi Compare (Edge)_Detected Position X	float	4 byte	2 word	Up to 10 multi-data can be transmitted ^[1]
Shape Multi Compare (Edge)_Detected Position Y	float	4 byte	2 word	Up to 10 multi-data can be transmitted ^[1]
Shape Multi Compare (Edge)_Detected Position Angle	float	4 byte	2 word	Up to 10 multi-data can be transmitted ^[1]
Shape Multi Compare (Edge)_Detected Position Width	float	4 byte	2 word	Up to 10 multi-data can be transmitted ^[1]
Shape Multi Compare (Edge)_Detected Position Height	float	4 byte	2 word	Up to 10 multi-data can be transmitted ^[1]

Work_Input	Data type	Data size	Modbus mapping size	Note
Shape Multi Compare (Edge)_Similarity (%)	float	4 byte	2 word	Up to 10 multi-data can be transmitted ^[1]
Shape Multi Compare (Edge)_Count	int	4 byte	2 word	
Shape Single Compare (Edge)_Result	bool	1 bit	1 word	
Shape Single Compare (Edge)_Detected Position X	float	4 byte	2 word	
Shape Single Compare (Edge)_Detected Position Y	float	4 byte	2 word	
Shape Single Compare (Edge)_Detected Position Angle	float	4 byte	2 word	
Shape Single Compare (Edge)_Detected Position Width	float	4 byte	2 word	
Shape Single Compare (Edge)_Detected Position Height	float	4 byte	2 word	
Shape Single Compare (Edge)_Similarity (%)	float	4 byte	2 word	
Shape Multi Compare (Pixel)_Result	bool	1 bit	1 word	
Shape Multi Compare (Pixel)_Detected Position X	float	4 byte	2 word	Up to 10 multi-data can be transmitted ^[1]
Shape Multi Compare (Pixel)_Detected Position Y	float	4 byte	2 word	Up to 10 multi-data can be transmitted ^[1]
Shape Multi Compare (Pixel)_Detected Position Angle	float	4 byte	2 word	Up to 10 multi-data can be transmitted ^[1]

Work_Input	Data type	Data size	Modbus mapping size	Note
Shape Multi Compare (Pixel)_Detected Position Width	float	4 byte	2 word	Up to 10 multi-data can be transmitted ^[1]
Shape Multi Compare (Pixel)_Detected Position Height	float	4 byte	2 word	Up to 10 multi-data can be transmitted ^[1]
Shape Multi Compare (Pixel)_Similarity (%)	float	4 byte	2 word	Up to 10 multi-data can be transmitted ^[1]
Shape Multi Compare (Pixel)_Count	int	4 byte	2 word	
Shape Single Compare (Pixel)_Result	bool	1 bit	1 word	
Shape Single Compare (Pixel)_Detected Position X	float	4 byte	2 word	
Shape Single Compare (Pixel)_Detected Position Y	float	4 byte	2 word	
Shape Single Compare (Pixel)_Detected Position Angle	float	4 byte	2 word	
Shape Single Compare (Pixel)_Detected Position Width	float	4 byte	2 word	
Shape Single Compare (Pixel)_Detected Position Height	float	4 byte	2 word	
Shape Single Compare (Pixel)_Similarity (%)	float	4 byte	2 word	
Arithmetic_Result	float	4 byte	2 word	
Conditional Comparison_Result	bool	1 bit	1 word	
Float to Integer_Integer	int	4 byte	2 word	

Work_Input	Data type	Data size	Modbus mapping size	Note
Integer to Float_Float	float	4 byte	2 word	
Rectangle Attribute_X Position	float	4 byte	2 word	
Rectangle Attribute_Y Position	float	4 byte	2 word	
Rectangle Attribute_Angle	float	4 byte	2 word	
Rectangle Attribute_Width	float	4 byte	2 word	
Rectangle Attribute_Height	float	4 byte	2 word	
Create Rectangle_Rectangle Area X	float	4 byte	2 word	
Create Rectangle_Rectangle Area Y	float	4 byte	2 word	
Create Rectangle_Rectangle Area Angle	float	4 byte	2 word	
Create Rectangle_Rectangle Area Width	float	4 byte	2 word	
Create Rectangle_Rectangle Area Height	float	4 byte	2 word	
Create Edge Detect Area_Edge Detection Area Start Point X	float	4 byte	2 word	
Create Edge Detect Area_Edge Detection Area Start Point Y	float	4 byte	2 word	
Create Edge Detect Area_Edge Detection Area End Point X	float	4 byte	2 word	

Work_Input	Data type	Data size	Modbus mapping size	Note
Create Edge Detect Area_Edge Detection Area End Point Y	float	4 byte	2 word	
Create Line Detect Area_Line Detection Area Start Point X	float	4 byte	2 word	
Create Line Detect Area_Line Detection Area Start Point Y	float	4 byte	2 word	
Create Line Detect Area_Line Detection Area End Point X	float	4 byte	2 word	
Create Line Detect Area_Line Detection Area End Point Y	float	4 byte	2 word	
Create Line Detect Area_Line Detection Area Width	float	4 byte	2 word	
Create Circle Detect Area_Circle Detection Area X	float	4 byte	2 word	
Create Circle Detect Area_Circle Detection Area Y	float	4 byte	2 word	
Create Circle Detect Area_Circle Detection Area Radius	float	4 byte	2 word	
Create Circle Detect Area_Circle Detection Area Width	float	4 byte	2 word	

1. Example of Multi-Data Transmission

If there are multiple inspection results in each inspection item, up to 10 data values for each inspection result can be transmitted through Modbus communication.

- Ex 1) Read Character result string is 'ABCDEF123456',
 Read Character Fixed ROI [0].X → Reads A of Fixed ROI X value
 Read Character Fixed ROI [1].X → Reads B of Fixed ROI X value

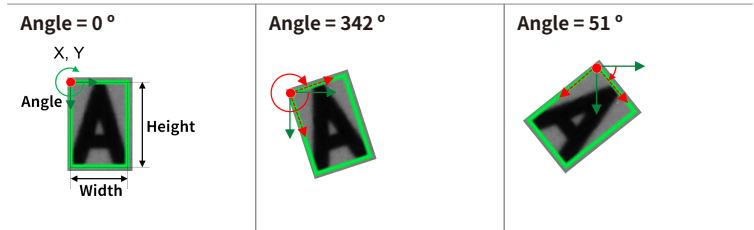

- Ex 2) The number of scans is over 10.
 It outputs 10 results ([0] to [9]) sorted in a clockwise direction based on the 3 o'clock point of the inspection area (circle).
 Diameter inspection area starting point [0].X → Starting point X1 at point [0]
 Diameter inspection area starting point [1].X → Starting point X1 at point [1]

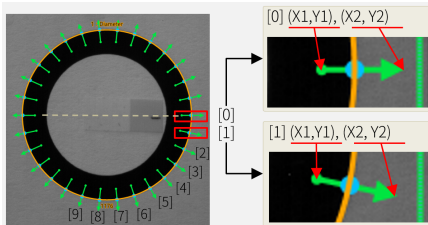

- Ex 3) Over 10 objects are detected in the object count inspection.
Based on the top left corner of the image, the top coordinate values of the detected object area are in descending order / when the top coordinate values are the same, it outputs 10 results ([0] to [9]) sorted in descending order of the left coordinate value.

Object number center point [0].X → Center point X of object [0]

Object number center point [1].X → Center point X of object [1]

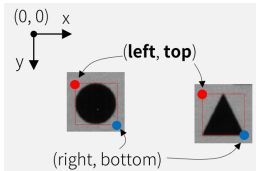
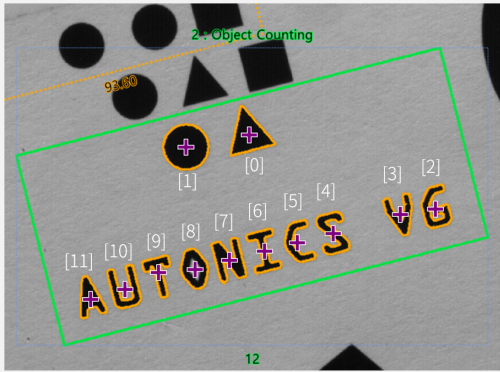

- Ex 4) Shape Multi Compare (Edge / Pixel) result exceeds 10,
In order of high similarity if the similarity is the same, or in order of the top coordinate values of the detected area in descending order if the top coordinate values are the same, it outputs 10 results ([0] to [9]) sorted in descending order of the left coordinate value.
Shape Multi Compare (Edge / Pixel) Fixed ROI [0].X → First Result of Fixed ROI X
Shape Multi Compare (Edge / Pixel) Fixed ROI [1].X → Second Result of Fixed ROI X

For examples of basic data result values, refer to "Supported data format and size" in 2.8.3.6, "Modbus".

Autonics

Dimensions or specifications on this manual are subject to change and some models may be discontinued without notice.

www.autonics.com