

Pneumatic linear cylinders

FESTO

(en) Operating
instructions



8104218
2018-12b
[8104220]

Translation of the original instructions
Pneumatic linear cylinder

Identification of hazards and instructions on how to prevent them:



Danger

Immediate dangers which can lead to death or serious injuries



Warning

Hazards that can cause death or serious injuries



Caution

Hazards that can cause minor injuries

Other symbols:



Note

Material damage or loss of function



Recommendations, tips, references to other documentation



Essential or useful accessories



Information on environmentally sound usage

Text designations:

- Activities that may be carried out in any order
- 1. Activities that should be carried out in the order stated
 - General lists
- ➔ Result of an action/References to more detailed information



For all available product documentation → www.festo.com/pk

1 Operating elements and connections

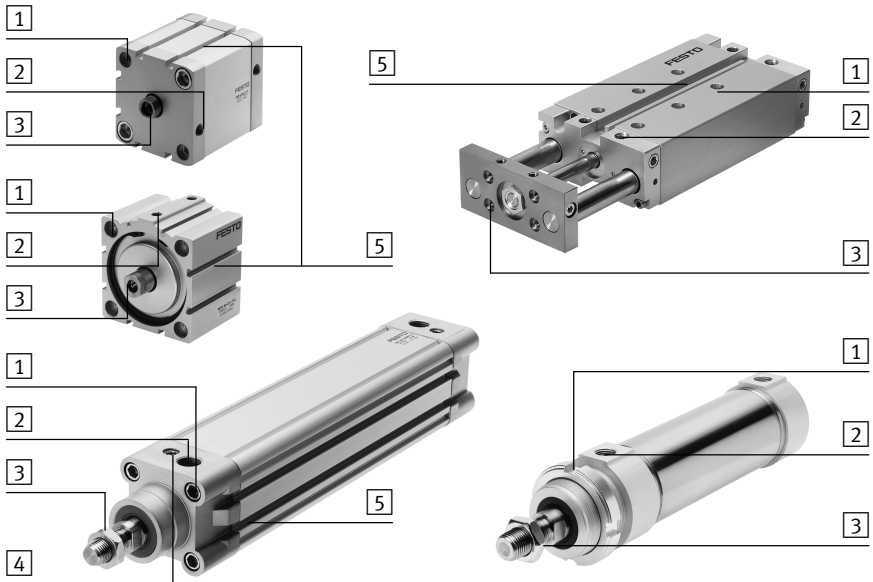

- | | |
|---|---|
| <p>1 Fastening possibilities depending on design:</p> <ul style="list-style-type: none"> - through-holes in the housing / bearing cover / end cover in the integrated flange – internal thread in the screws of the bearing cover or end cover - external thread on the bearing cover / end cover - transverse bore in the flattened pivot of the bearing cover / end cover <p>2 Compressed air connections in the bearing/end covers or directly in the housing</p> | <p>3 Thread for fastening the load:</p> <ul style="list-style-type: none"> - external thread on the piston rod - internal thread in the piston rod or - internal thread in the front plate <p>4 Adjusting screws for end position cushioning in the bearing/end covers (only on cylinders with adjustable end position cushioning)</p> <p>5 Groove for proximity switch</p> |
|---|---|

2 Function

When the cylinder chamber is pressurized, the piston moves forwards in the barrel. The piston rod transmits the movement to the outside. The extended piston rod is moved back by spring force on single-acting cylinders and by pressurization of the other cylinder chamber on double-acting cylinders.

The end positions can be detected by means of proximity switches in the grooves.

On double-acting cylinders, the cross-sectional area of the piston rod causes differences of force between forward stroke and the return stroke (exception: with double-ended piston rod).

3 Conditions of use



Please note

Incorrect handling can result in malfunctions.

- Ensure that the specifications in this chapter are always observed. This is the only way to ensure correct and safe operation of the product.

- Observe the maximum limits specified in the catalogue (e.g. for pressures, forces, torques, masses, speeds, temperatures).
- Make sure there is a supply of correctly-prepared compressed air.
- Please observe the prevailing ambient conditions.
- Observe also the standards specified in the relevant chapters, as well as national and local laws and technical regulations.
- Remove all transport safety measures such as protective wax, foils, caps, cardboard boxes.
The individual materials can be stored in containers for recycling purposes.

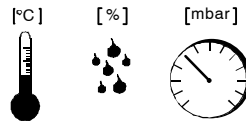

Fig. 1

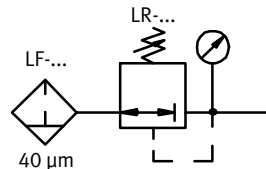

Fig. 2



Pneumatic linear cylinder

- Use the same medium composition throughout the service life of the product.
Example:
selected: non-lubricated compressed air
continue to use: non-lubricated compressed air.
- Slowly pressurize the complete system.
This will prevent uncontrolled movements from occurring.



Fig. 3

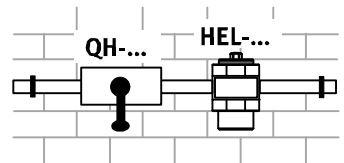

Fig. 4

4 Installation

Mechanical installation

- Check whether the type designation of the cylinder to be fitted is the same as that of the desired cylinder.
- Handle the cylinder with care so that the cylinder barrel and the piston rod are not damaged.
This would reduce operational reliability and the service life.
- Place the cylinder on the support so that the adjusting screws for the end position cushioning are always accessible.
- Make sure that:
 - external guides, if used, are fitted parallel,
 - they are not distorted and
 - the maximum permitted loadings as per catalogue are not exceeded.
- Observe the maximum tightening torques specified in the catalogue for screws, locking nuts or accessories.

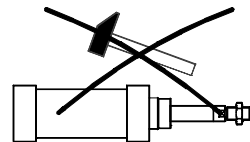

Fig. 5

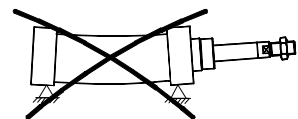

Fig. 6

Pneumatic installation

Definition

Moveable mass = work load + piston (rod) mass

- Use one-way flow control valves for setting the speed of the piston.

With single-acting cylinders	With double-acting cylinders
Type GRLZ (supply air flow control)	Type GRLA (exhaust flow control)

Fig. 7

The GRL... are screwed directly into the compressed air ports. Other accessory parts with excessive screw-in length will damage the cushioning piston.

- Check to see if closed-loop controlled non-return valves type HGL... are necessary.

You will then prevent the moveable mass sliding down if there is a drop in pressure when the product is fitted in a vertical or sloping position.

If an external guide is used:

- Avoid a mechanical overdetermination of the piston rod by one of the following measures:
 - absolutely exact alignment (general)
 - the use of a self-aligning rod coupling type FK...
 - the use of a guide unit type FEN... with compensating coupling

A rigid coupling will impair the service life and the function of the cylinder.

5 Commissioning

Complete system

- Slowly pressurize the complete system.

This will prevent uncontrolled movements from occurring.

For slow start-up pressurization use safety start-up valve type HEL-... .

Individual unit



Warning

1. Make sure that:
 - nobody can place his/her hand in the positioning range of the moveable mass
 - there are no objects in the positioning range.

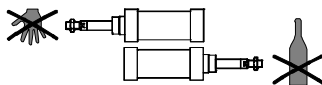

Fig. 8

2. Close both upstream one-way flow control valves:
 - at first completely,
 - then loosen approximately one turn.
3. Close the adjusting screws for the end position cushioning
 - at first completely (with DNCB-.. close completely);
 - then loosen again approximately one turn (with DNCB-... $\frac{1}{4}$ turn).
4. Note that adjustable end position cushionings may have no effect if used in conjunction with fitted quick exhaust valves.
This depends on the flow ratio of the exhaust air.
5. Exhaust the cylinder slowly on one side.
Otherwise excessive loadings will occur during the first move, if the piston moves too quickly into an end position.
For slow start-up pressurization use safety start-up valve type HEL-... .
6. Start a test run.
7. During a test run check whether the following settings on the cylinder need to be modified:
 - the end position cushioning
 - the speed of the moveable mass.

With masses which project longitudinally over the bearing/end cover:

In this case the following screws may only be turned when the cylinder is at a stand:

- the adjusting screws for the one-way flow control valves
- the adjusting screws for the end position cushioning.

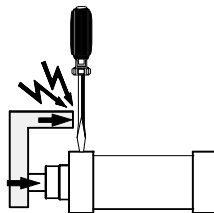

Fig. 9

8. Unscrew the one-way flow control valves slowly until the desired piston speed is reached.
9. Open the adjusting screws on both sides as desired for the end position cushioning.

The following applies for the cushioning setting:

With adjustable end position cushioning	With non-adjustable end position cushioning
The piston should reach the end positions safely at the desired cycle times, but not strike hard against them.	The maximum limits for masses, speeds and energy specified in the catalogue must be observed.

Fig. 10

6 Operation



Warning

- Make sure that:
 - nobody can place his/her hand in the positioning range of the moveable mass
 - there are no objects in the positioning range.

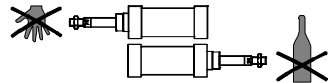

Fig. 11

It must not be possible to touch the cylinder until the mass has come to a complete stand.

With a large work load, high piston speed or when quick exhaust valves are used:

- Use suitable external shock absorbers or external stops.

- Place the proximity switches as follows:

With cylinders with groove	With cylinders without groove
In the integrated groove for proximity switches.	Or with a fastening kit so that the proximity switches lie properly on the cylinder barrel.

Fig. 12

- Always use proximity switches at the distances specified.
If the gap is too large, the switch will not be actuated reliably.

7 Care and maintenance

- If the piston rod is dirty, clean it with a soft cloth.
All non-abrasive cleaning agents are permitted.
Otherwise the cylinders do not require maintenance due to their service life lubrication. Regular removal of the lubricating grease on the surface of the piston rod will reduce the service life.

8 Dismantling and repairs

With non-roller-burnished cylinders:

- Make use of the opportunity to have your cylinder overhauled by the Festo repair service.
- Order a suitable wearing-parts set if your cylinder shows the following signs of wear:
 - loss of power during operation
 - increased air consumption
 - (noise emission).

An overview of wearing parts available can be found at the Internet address (see last page of these instructions).

Roller-burnished cylinders cannot be overhauled.

Pneumatic linear cylinder

- Make sure that your cylinder corresponds to the type designation in the catalogue.

Replacing worn parts



Warning

- Make sure that the bearing cover cannot suddenly fly off.

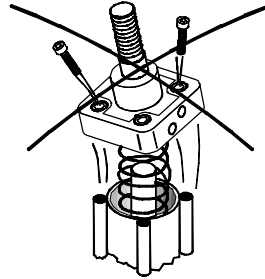

Fig. 13

Situation	Single-acting cylinders	Tubing with non-return valves
Possible procedure	The spring unbends suddenly	The pressure is released suddenly
Counter measure	Use counter holding device	Remove non-return valves

Fig. 15

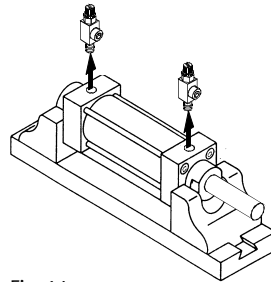

Fig. 14

- Handle the individual parts of the cylinder with care so that the sealing edges and the guide surfaces are not damaged (e.g. by using suitable mounting aids). Particular burrs on sealing surfaces can reduce operational reliability.

If the piston rod is distorted:

- Send the piston rod together with the screwed-on piston to Festo.
- Observe the following points when fitting the cylinder together again:
 - Use a locking agent on all screwed parts.
 - Lubricate the moving parts or specified parts with the lubricating grease supplied.
 - The environment must be clean.

9 Accessories

The necessary accessories for the individual cylinder types can be found in the Festo Catalogue.

10 Trouble-shooting

Fault	Possible cause	Remedy
Uneven movement of the piston (cylinder jerks)	Lubrication missing	Lubricate with correct grease (e.g. as per instructions with wearing parts)
	Flow control valves inserted incorrectly	If possible restrict exhaust
	Piston rod dirty	Clean, provide cover (after intensive cleaning or subsequent lubrication)
	Not enough supply air (stick slip)	<ul style="list-style-type: none"> – Keep the tubing short and select suitable cross-sectional areas – Select correct pressure – Keep pressure constant
	Not enough pressure	Switch volume upstream
	Piston seal or piston rod seal defective	Send the cylinder to Festo for repairs or Replace wearing parts
	Guide not parallel to direction of stroke	Use a self-aligning rod coupling as per “Accessories” (see specifications in catalogue)

Fault	Possible cause	Remedy
Piston does not reach the stroke end position	Cylinder barrel damaged	Replace cylinder
	Adjusting screw of end position cushioning completely closed	Open adjusting screw
	Foreign matter in the cylinder	Remove foreign matter, filter the compressed air
	Cylinder moves to an external end stop	Readjust end stop
Incorrect switching during position recognition	Temperatures too high/low	Observe the permitted temperature range of the proximity switches
	Fault in the proximity switch	See instructions for proximity switch
	Piston without magnet fitted	Use piston with magnet

Fig. 16

11 Technical specifications

Type	
Medium	Filtered compressed air (filter fineness: 40 µm), lubricated or non-lubricated
Mounting position	As desired
End-position cushioning	<ul style="list-style-type: none"> – Elastic cushioning rings/plates (P cushioning) – Pneumatic cushioning (PPV cushioning) – Self-adjusting shock absorber (YSR cushioning) – Adjustable shock absorber (YSR) cushioning)

Fig. 17

Copyright:
Festo SE & Co. KG
Ruiter Straße 82
73734 Esslingen
Germany

Phone:
+49 711 347-0

Fax:
+49 711 347-2144

E-mail:
service_international@festo.com

Internet:
www.festo.com

Reproduction, distribution or sale of this document or communication of its contents to others without express authorization is prohibited. Offenders will be liable for damages. All rights reserved in the event that a patent, utility model or design patent is registered.