

Angle gripper DHWC



## Characteristics

### At a glance

[Link](#)  [dhwc](#)

- Lateral gripper jaw support for high torque loads
- Gripper jaw centring options
- Max. repetition accuracy
- Proximity switch for sensing the piston position in the end positions and position transmitter for sensing the piston position at any point
- Wide range of adaptation options on the drives
- Flexible application options: can be used as a double- and single-acting gripper

These grippers are not designed for the following or similar application examples:

- Machining
- Aggressive media
- Grinding dust
- Welding spatter

### Engineering tools

[Link](#)  [engineering tools](#)



Save time with engineering tools Smart Engineering for the optimal solution. Our goal is to increase your productivity. Our engineering tools play an integral part in this. They help you size your system correctly, tap into unimagined productivity reserves and generate additional productivity along the entire value chain. In every phase of your project, from the initial contact to the modernisation of your machine, you will come across a number of different tools which will be of use to you.

Gripper selection:

- This tool helps you to select the right grippers by simply entering the exact parameters for your application

### Diagrams

[Link](#)  [dhwc](#)



The diagrams shown in this document are also available online. These can be used to display precise values.

### Position sensing

[A] For proximity sensor

By using proximity switches, any position can be detected.

### Gripper function

[ ] Double-acting

Opening or closing by applying compressed air

[S] Single-acting, open

Open when depressurised. Closed when pressurised with compressed air

### Gripping force backup

[NO] Opening

Opened by spring force in depressurised state

Type code

|      |               |  |
|------|---------------|--|
| 001  | Series        |  |
| DHWC | Angle gripper |  |

|     |           |  |
|-----|-----------|--|
| 002 | Size [mm] |  |
| 6   | 6         |  |
| 10  | 10        |  |
| 16  | 16        |  |
| 20  | 20        |  |
| 25  | 25        |  |
| 32  | 32        |  |

|     |                      |  |
|-----|----------------------|--|
| 003 | Position sensing     |  |
| A   | For proximity sensor |  |

|     |                     |  |
|-----|---------------------|--|
| 004 | Gripper function    |  |
|     | Double-acting       |  |
| S   | Single-acting, open |  |

|     |                       |  |
|-----|-----------------------|--|
| 005 | Gripping force backup |  |
|     | None                  |  |
| NO  | Opening               |  |

Datasheet

| General technical data                     |   |  |  |       |    |    |
|--|---|--|--|-------|----|----|
| Size                                       | 6   | 10                                     | 16   | 20    | 25 | 32 |
| Design                                     | Connection direction at side<br>Force pilot operated motion sequence      |  |  |       |    |    |
| Mode of operation                          | Double-acting   | Double-acting<br>Single-acting<br>Open |  |       |    |    |
| Gripper function                           | Angle   |  |  |       |    |    |
| Number of gripper jaws                     | 2   |  |  |       |    |    |
| Max. opening angle                         | 30 deg  |  |  |       |    |    |
| Pneumatic connection                       | M3  |  |  | M5    |    |    |
| Repetition accuracy, gripper <sup>1)</sup> | ≤0.1 mm   |  |  |       |    |    |
| Rotationally symmetrical                   | -   |  | ≤0.2 mm  |       |    |    |
| Max. replacement accuracy                  | ≤0.2 mm   |  |  |       |    |    |
| Max. operating frequency of gripper        | ≤3 Hz   |  |  | ≤2 Hz |    |    |
| Position detection                         | Via proximity switch  |  |  |       |    |    |
| Type of mounting                           | Either:<br>Direct mounting via through-hole<br>Direct mounting via thread |  | Either:<br>Direct mounting via through-hole<br>Direct mounting via thread<br>Via through-hole and dowel pin<br>Via female thread and dowel pin |       |    |    |
| Mounting position                          | optional  |  |  |       |    |    |

1) Under constant exposure to operating conditions, end-position drift occurs in the direction of movement of the gripper jaws at 100 consecutive strokes

| Operating and environmental conditions       |  |    |    |    |    |    |
|--|--|----|----|----|----|----|
| Size   | 6  | 10 | 16 | 20 | 25 | 32 |
| Operating medium                             | Compressed air to ISO 8573-1:2010 [7:4:4]  |    |    |    |    |    |
| Note on operating and pilot medium           | Lubricated operation possible (in which case lubricated operation will always be required) |    |    |    |    |    |
| Ambient temperature <sup>1)</sup>            | -10 ... 60°C   |    |    |    |    |    |
| Corrosion resistance class CRC <sup>2)</sup> | 0 - No corrosion stress  |    |    |    |    |    |

1) Note the operating range of the proximity switches

2) More information [www.festo.com/x/topic/crc](http://www.festo.com/x/topic/crc)

| Operating pressure – DHWC-... |                   |    |                  |    |    |    |
|-------------------------------|-------------------|----|------------------|----|----|----|
| Size                          | 6                 | 10 | 16               | 20 | 25 | 32 |
| Operating pressure            | 0.25 ... 0.8 MPa  |    | 0.1 ... 0.8 MPa  |    |    |    |
| Operating pressure            | 36.25 ... 116 psi |    | 14.5 ... 116 psi |    |    |    |
| Operating pressure            | 2.5 ... 8 bar     |    | 1 ... 8 bar      |    |    |    |

| Operating pressure – DHWC-...-NO |                 |    |                   |    |    |  |
|----------------------------------|-----------------|----|-------------------|----|----|--|
| Size                             | 10              | 16 | 20                | 25 | 32 |  |
| Operating pressure               | 0.2 ... 0.8 MPa |    | 0.15 ... 0.8 MPa  |    |    |  |
| Operating pressure               | 29 ... 116 psi  |    | 21.75 ... 116 psi |    |    |  |
| Operating pressure               | 2 ... 8 bar     |    | 1.5 ... 8 bar     |    |    |  |

| Weight – DHWC-... |      |      |      |         |       |       |
|-------------------|------|------|------|---------|-------|-------|
| Size              | 6    | 10   | 16   | 20      | 25    | 32    |
| Product weight    | 22 g | 48 g | 97 g | 189.3 g | 362 g | 639 g |

| Weight – DHWC-...-NO |        |        |         |         |       |  |
|----------------------|--------|--------|---------|---------|-------|--|
| Size                 | 10     | 16     | 20      | 25      | 32    |  |
| Product weight       | 53.5 g | 97.5 g | 190.5 g | 363.5 g | 642 g |  |

## Datasheet

| Materials             |                                   |    |    |    |    |    |
|-----------------------|-----------------------------------|----|----|----|----|----|
| Size                  | 6                                 | 10 | 16 | 20 | 25 | 32 |
| Material housing      | Anodised wrought aluminium alloy  |    |    |    |    |    |
| Material gripper jaws | High-alloy steel                  |    |    |    |    |    |
| Material cover cap    | Wrought aluminium alloy, anodised |    |    |    |    |    |
| Note on materials     | RoHS-compliant                    |    |    |    |    |    |

### Total gripping torque

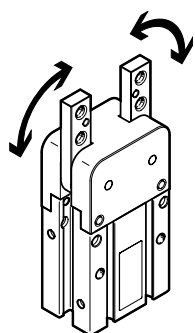

The gripping torque is not constant across the opening angle.

| Total gripping torque – DHWC...                           |         |          |          |           |           |           |
|---|---------|----------|----------|-----------|-----------|-----------|
| Size  | 6       | 10       | 16       | 20        | 25        | 32        |
| Total gripping torque at 0.6 MPa (6 bar, 87 psi), opening | 7.3 Ncm | 25.1 Ncm | 78.2 Ncm | 173.5 Ncm | 322.6 Ncm | 687.6 Ncm |
| Total gripper torque, closing, 0.6 MPa (6 bar, 87 psi)    | 5.4 Ncm | 20.6 Ncm | 65.7 Ncm | 142.9 Ncm | 265.1 Ncm | 578.6 Ncm |

| Total gripping torque – DHWC...-NO                     |          |          |           |           |           |
|--|----------|----------|-----------|-----------|-----------|
| Size   | 10       | 16       | 20        | 25        | 32        |
| Total gripper torque, closing, 0.6 MPa (6 bar, 87 psi) | 15.9 Ncm | 53.3 Ncm | 120.9 Ncm | 233.9 Ncm | 550.7 Ncm |

### Characteristic load values at the gripper jaws

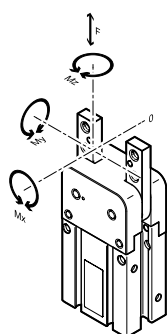

The indicated permissible forces and torques apply to a single gripper jaw. They include the lever arm, additional applied loads created by the workpiece or external gripper fingers and acceleration forces occurring during movement. The zero coordinate line (gripper jaw guide) must be taken into account when calculating torques.

| Characteristic load values at the gripper jaws |        |        |        |        |        |       |
|--|--------|--------|--------|--------|--------|-------|
| Size   | 6      | 10     | 16     | 20     | 25     | 32    |
| Max. force on gripper jaw $F_z$ static         | 18 N   | 40 N   | 60 N   | 100 N  | 140 N  | 210 N |
| Max. torque at gripper $M_x$ static            | 0.3 Nm | 0.4 Nm | 1.2 Nm | 1.5 Nm | 2.2 Nm | 5 Nm  |
| Max. torque at gripper $M_y$ static            | 0.3 Nm | 0.5 Nm | 0.9 Nm | 2.2 Nm |        | 5 Nm  |
| Max. torque at gripper $M_z$ static            | 0.3 Nm | 0.5 Nm | 0.9 Nm | 2.2 Nm |        | 5 Nm  |

Datasheet

Gripping force F per gripper jaw as a function of operating pressure and lever arm x

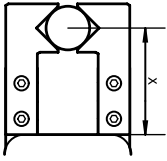

The gripping forces as a function of operating pressure and lever arm can be determined from the following graphs.

The gripping torque is not constant across the opening angle.

Sizing software for gripper selection → <https://www.festo.com/x/topic/eng>

Gripping force F per gripper jaw as a function of operating pressure and lever arm x – External gripping (closing), double-acting – DHWC-6-A

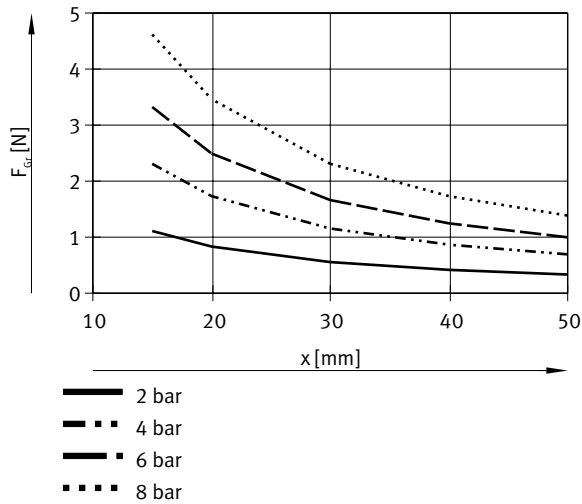

Gripping force F per gripper jaw as a function of operating pressure and lever arm x – External gripping (closing), double-acting – DHWC-10-A

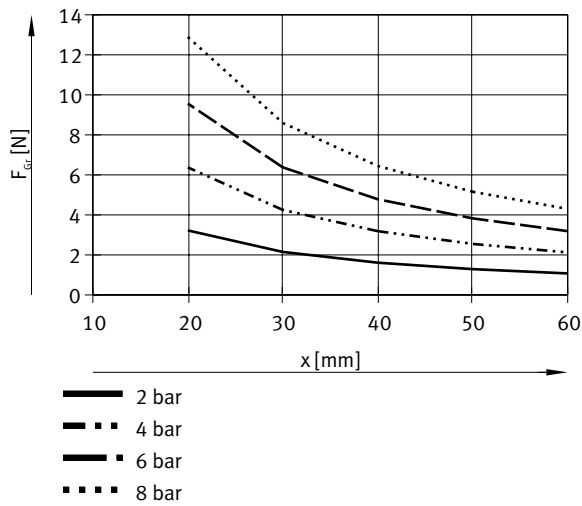

Datasheet

Gripping force F per gripper jaw as a function of operating pressure and lever arm x – External gripping (closing), double-acting – DHWC-16-A

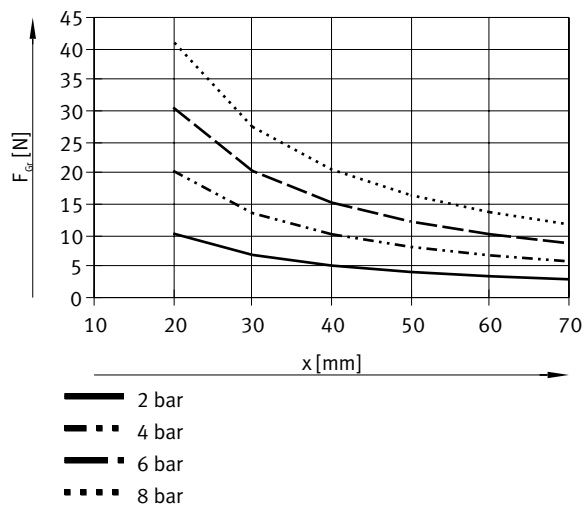

Gripping force F per gripper jaw as a function of operating pressure and lever arm x – External gripping (closing), double-acting – DHWC-20-A

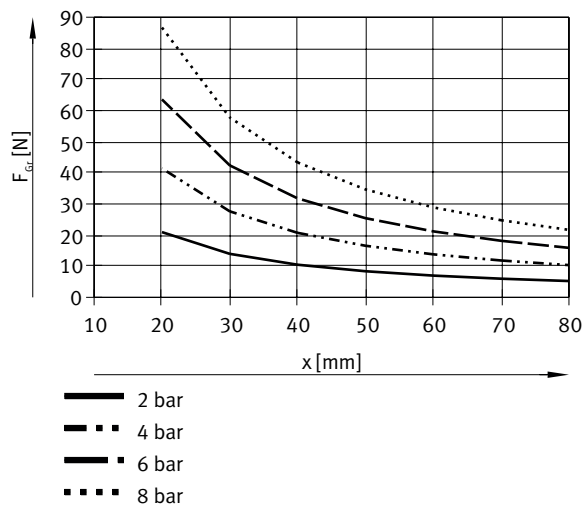

Datasheet

Gripping force  $F$  per gripper jaw as a function of operating pressure and lever arm  $x$  – External gripping (closing), double-acting – DHWC-25-A

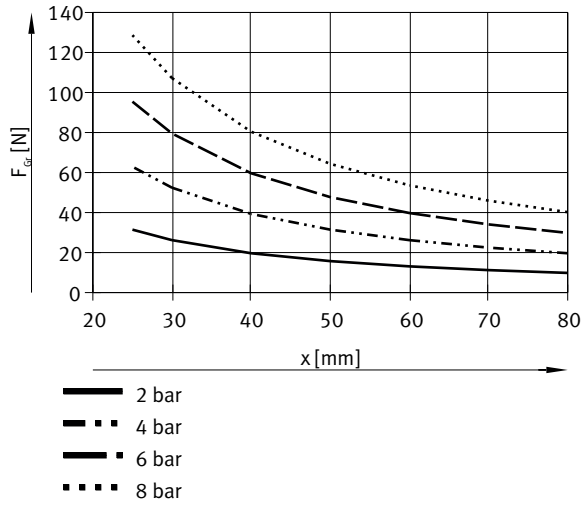

Gripping force  $F$  per gripper jaw as a function of operating pressure and lever arm  $x$  – External gripping (closing), double-acting – DHWC-32-A

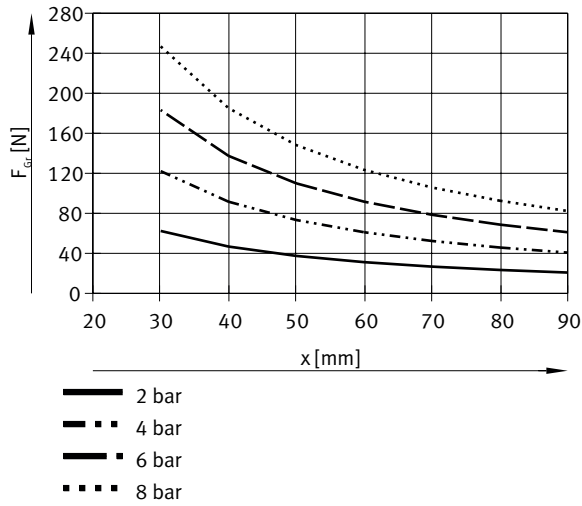



## Datasheet

Gripping force  $F$  per gripper jaw as a function of operating pressure and lever arm  $x$  – External gripping (closing), single-acting – DHWC-10-A-S-NO

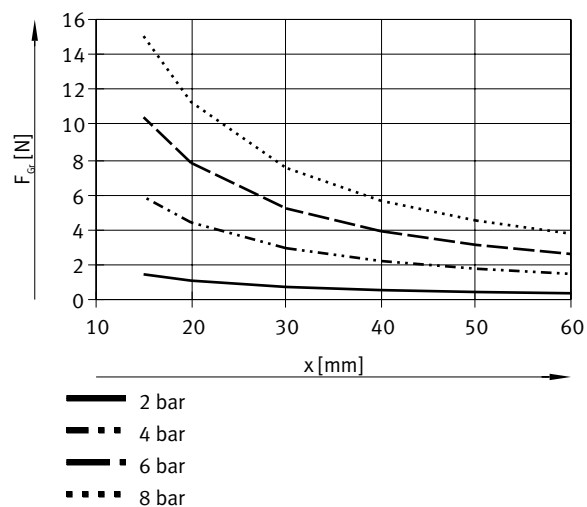

Gripping force  $F$  per gripper jaw as a function of operating pressure and lever arm  $x$  – External gripping (closing), single-acting – DHWC-16-A-S-NO

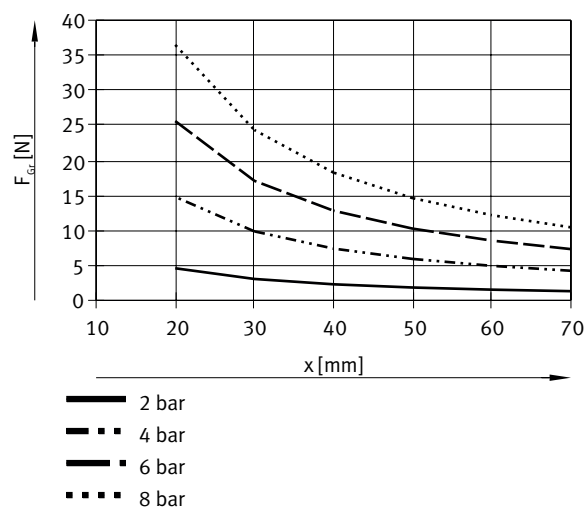

Datasheet

Gripping force  $F$  per gripper jaw as a function of operating pressure and lever arm  $x$  – External gripping (closing), single-acting – DHWC-20-A-S-NO

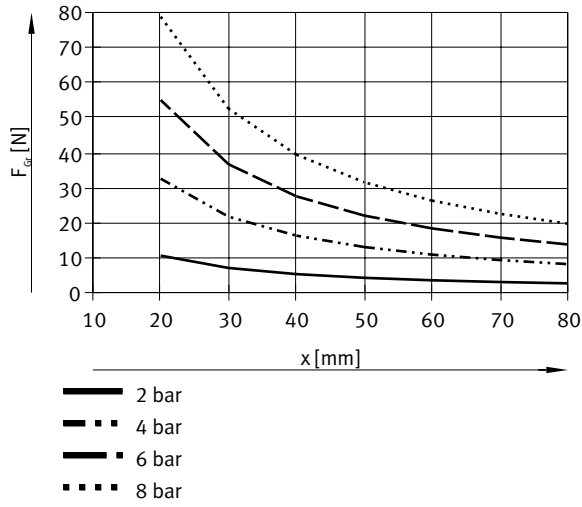

Gripping force  $F$  per gripper jaw as a function of operating pressure and lever arm  $x$  – External gripping (closing), single-acting – DHWC-25-A-S-NO

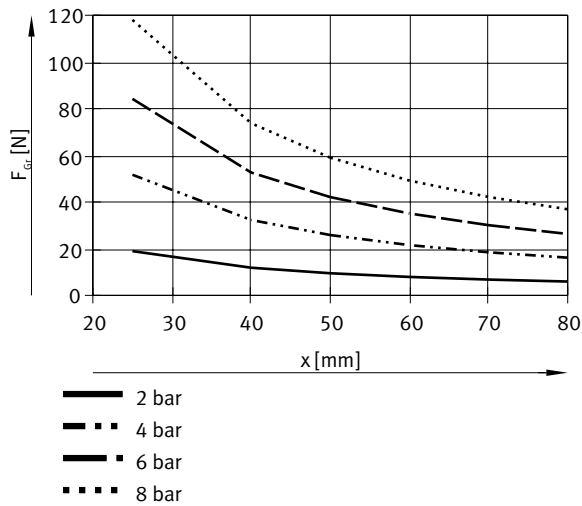

Datasheet

Gripping force  $F$  per gripper jaw as a function of operating pressure and lever arm  $x$  – External gripping (closing), single-acting – DHWC-32-A-S-NO

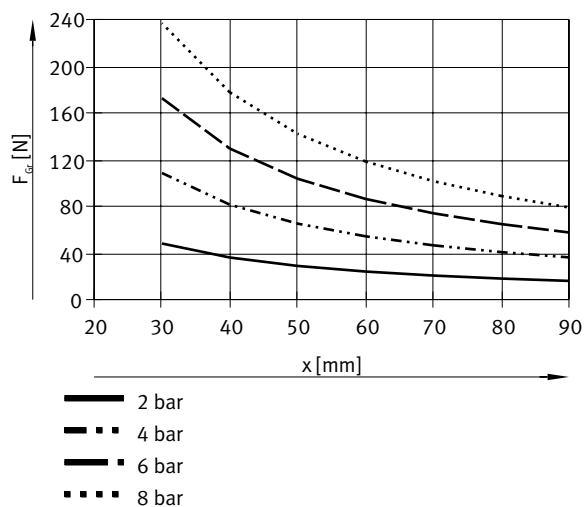

Gripping force  $F$  per gripper jaw as a function of operating pressure and lever arm  $x$  – Internal gripping (opening), double-acting – DHWC-6-A

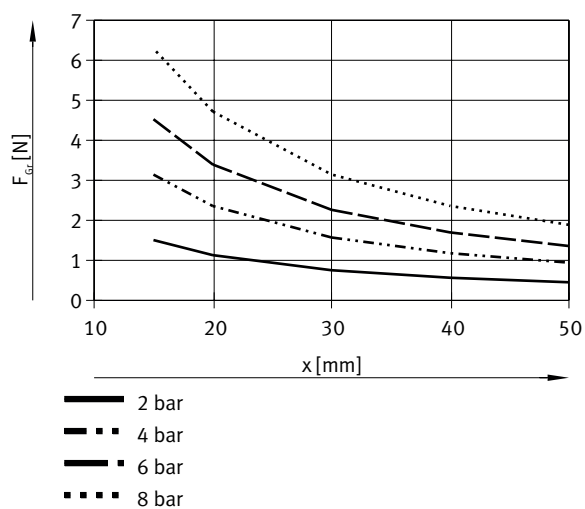

Datasheet

Gripping force  $F$  per gripper jaw as a function of operating pressure and lever arm  $x$  – Internal gripping (opening), double-acting – DHWC-10-A

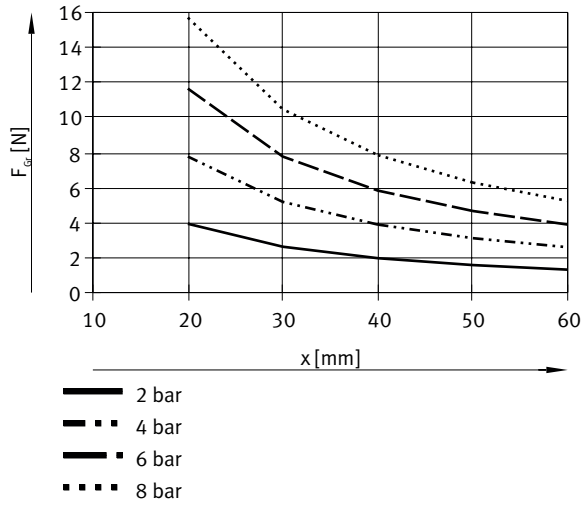

Gripping force  $F$  per gripper jaw as a function of operating pressure and lever arm  $x$  – Internal gripping (opening), double-acting – DHWC-16-A

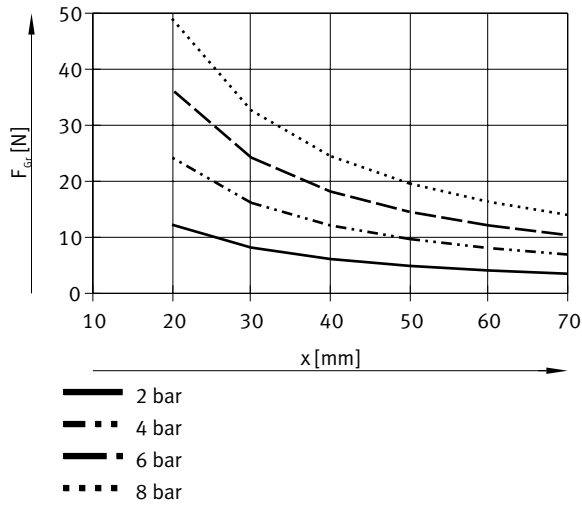

## Datasheet

Gripping force  $F$  per gripper jaw as a function of operating pressure and lever arm  $x$  – Internal gripping (opening), double-acting – DHWC-20-A

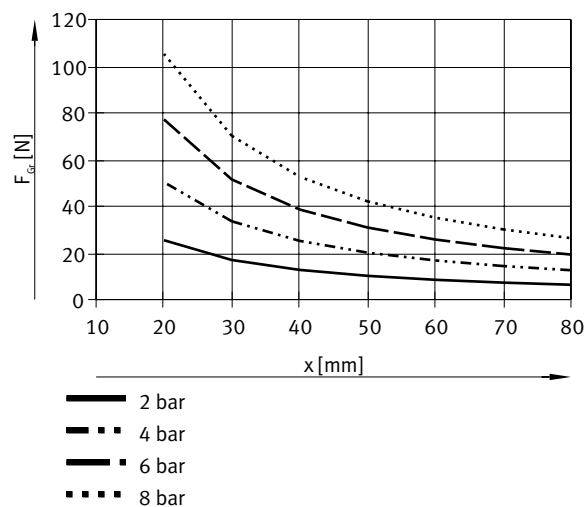

Gripping force  $F$  per gripper jaw as a function of operating pressure and lever arm  $x$  – Internal gripping (opening), double-acting – DHWC-25-A

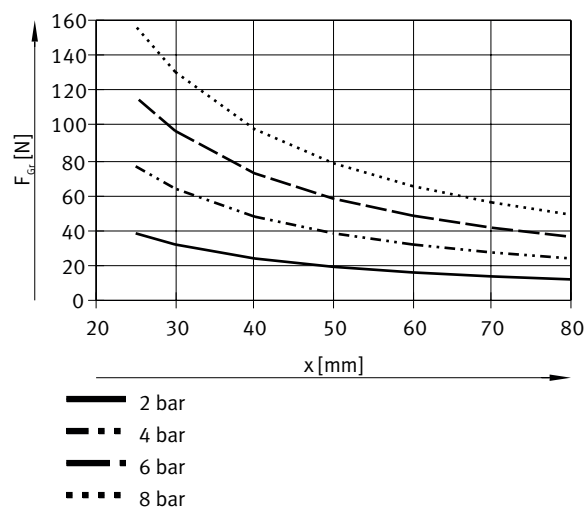

Datasheet

Gripping force F per gripper jaw as a function of operating pressure and lever arm x – Internal gripping (opening), double-acting – DHWC-32-A

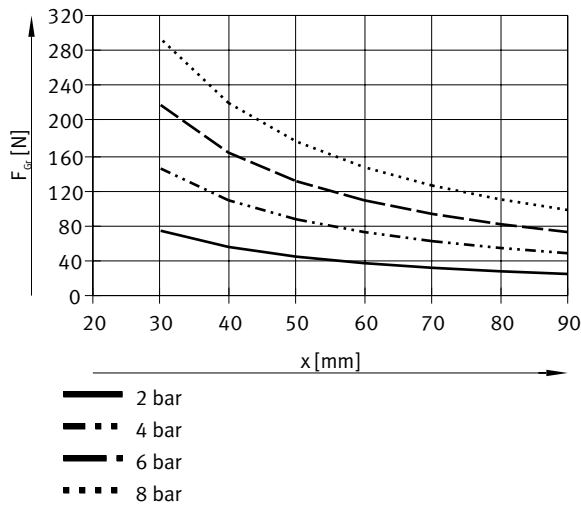

Gripping force F per gripper jaw at 0.6 MPa (6 bar, 87 psi) as a function of lever arm x and eccentricity a and b

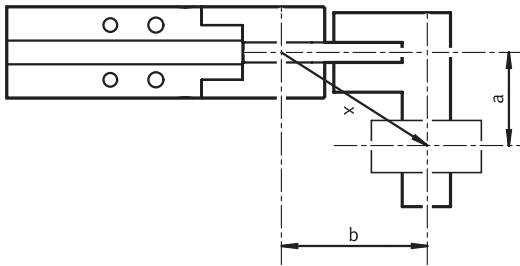

Gripping force F per gripper jaw at 0.6 MPa (6 bar, 87 psi) as a function of lever arm x and eccentricity a and b

$$x = \sqrt{a^2 + b^2} = \sqrt{20^2 + 25^2} = 32 \text{ mm}$$

The formula (on the left) must be used to calculate the lever arm x with eccentric gripping.  
 The gripping force F can then be read from the graphs using the calculated value x.

Calculation example:

Assuming:

Distance a = 20 mm

Distance b = 25 mm

To be determined:

The gripping force at 6 bar, with a DHWC-16-A, used as an external gripper.

## Datasheet

### Gripping force F per gripper jaw at 0.6 MPa (6 bar, 87 psi) as a function of lever arm x and eccentricity a and b

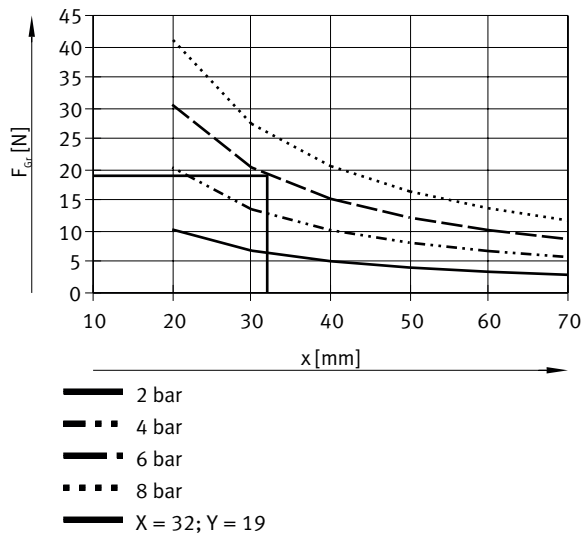

The graph gives a value of  $F = 20$  N for the gripping force.

### Torque curve M as a function of opening angle

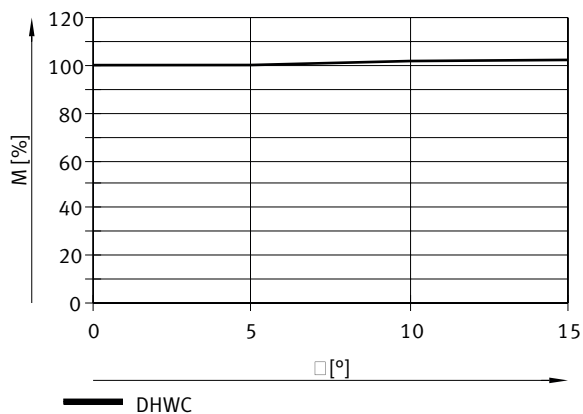

The drive principle of the gripper jaws means that the torque is not constant across the opening angle. The percentage available in each case can be calculated in the graph.

Opening angle of  $0^\circ$  means: parallel gripper jaw position.

### Spring moment M as a function of the opening angle

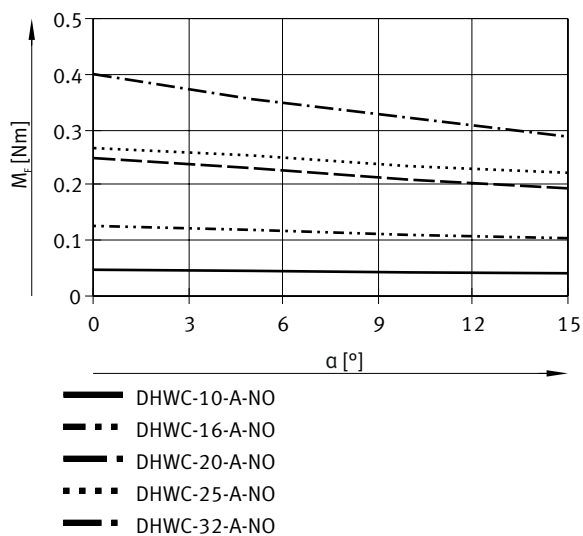

Calculation of the actual gripping torques M for DHWC...-S-NO as a function of the application:

Depending on the requirements, the gripper with built-in spring, DHWC...-S-NO (opening), can be used as a single-acting gripper.

To calculate the available gripping torque  $M_{Grtotal}$  (per gripper jaw), the data from the graphs for the gripping force  $F_{Gr}$ , the torque curve M and the spring torque MF must be combined accordingly.

$$M_{Gr} = F_{Gr} \cdot x \cdot M \quad [\%]$$

$M_{Gr}$  = Gripping torque

$F_{Gr}$  = Gripping force

x = Lever arm

M = Torque curve

Datasheet

Mass moments of inertia

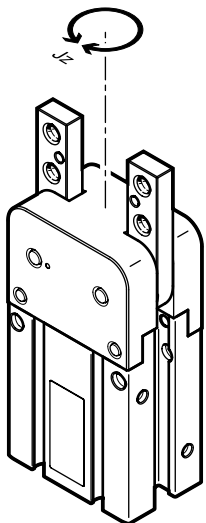

Mass moment of inertia of the gripper in relation to the central axis, without external gripper fingers, with no load.

Mass moments of inertia – DHWC...

| Size                   | 6                       | 10                      | 16                      | 20                      | 25                      | 32                      |
|------------------------|-------------------------|-------------------------|-------------------------|-------------------------|-------------------------|-------------------------|
| Mass moment of inertia | 0.009 kgcm <sup>2</sup> | 0.035 kgcm <sup>2</sup> | 0.115 kgcm <sup>2</sup> | 0.253 kgcm <sup>2</sup> | 1.083 kgcm <sup>2</sup> | 2.769 kgcm <sup>2</sup> |

Mass moments of inertia – DHWC...-NO

| Size                   | 10                      | 16                      | 20                      | 25                      | 32                      |
|------------------------|-------------------------|-------------------------|-------------------------|-------------------------|-------------------------|
| Mass moment of inertia | 0.039 kgcm <sup>2</sup> | 0.116 kgcm <sup>2</sup> | 0.255 kgcm <sup>2</sup> | 1.087 kgcm <sup>2</sup> | 2.782 kgcm <sup>2</sup> |

Opening and closing times

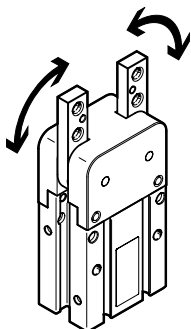

The indicated opening and closing times [ms] were measured at room temperature at an operating pressure of 0.6 MPa (6 bar, 87 psi) with a horizontally mounted gripper and without additional gripper fingers (mean values shown). The grippers must be throttled for larger applied loads. Opening and closing times must then be adjusted accordingly.

Opening and closing times – DHWC...

| Size   | 6    | 10   | 16    | 20    | 25    | 32    |
|--|------|------|-------|-------|-------|-------|
| Min. opening time at 0.6 MPa (6 bar, 87 psi) | 4 ms | 8 ms | 4 ms  | 6 ms  | 38 ms | 22 ms |
| Min. closing time at 0.6 MPa (6 bar, 87 psi) | 7 ms | 8 ms | 12 ms | 16 ms | 50 ms | 34 ms |

Opening and closing times – DHWC...-NO

| Size   | 10    | 16    | 20    | 25    | 32    |
|--|-------|-------|-------|-------|-------|
| Min. opening time at 0.6 MPa (6 bar, 87 psi) | 6 ms  | 20 ms | 13 ms | 51 ms | 43 ms |
| Min. closing time at 0.6 MPa (6 bar, 87 psi) | 12 ms | 14 ms | 10 ms | 15 ms | 16 ms |



## Datasheet

Opening and closing times T to be set at 0.6 MPa (6 bar, 87 psi) as a function of mass moment of inertia of the gripper fingers – DHWC-6

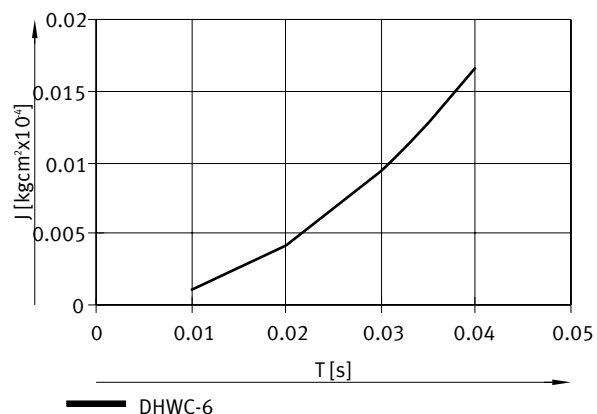

Opening and closing times T to be set at 0.6 MPa (6 bar, 87 psi) as a function of mass moment of inertia of the gripper fingers – DHWC-10

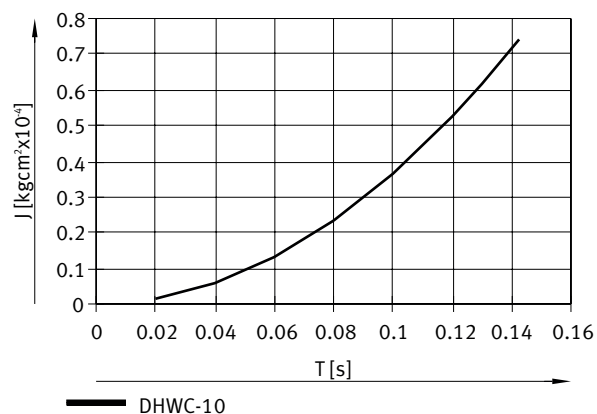

Opening and closing times T to be set at 0.6 MPa (6 bar, 87 psi) as a function of mass moment of inertia of the gripper fingers – DHWC-16

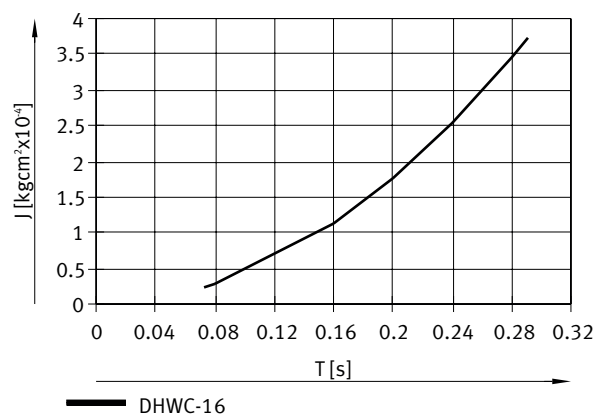

Datasheet

Opening and closing times T to be set at 0.6 MPa (6 bar, 87 psi) as a function of mass moment of inertia of the gripper fingers – DHWC-20

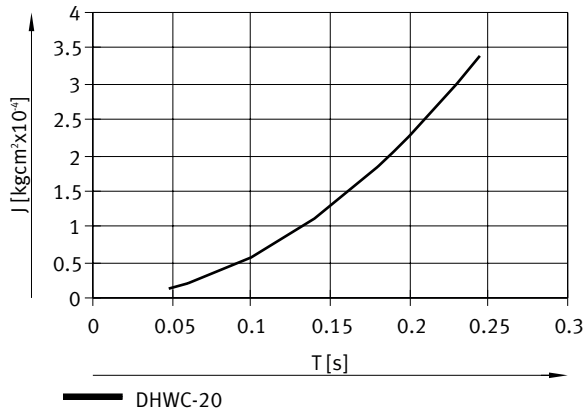

Opening and closing times T to be set at 0.6 MPa (6 bar, 87 psi) as a function of mass moment of inertia of the gripper fingers – DHWC-25

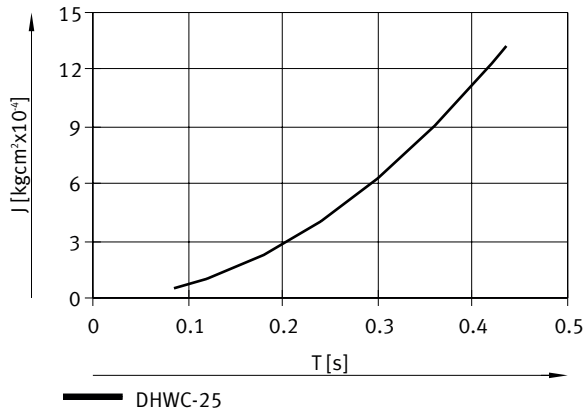

Opening and closing times T to be set at 0.6 MPa (6 bar, 87 psi) as a function of mass moment of inertia of the gripper fingers – DHWC-32

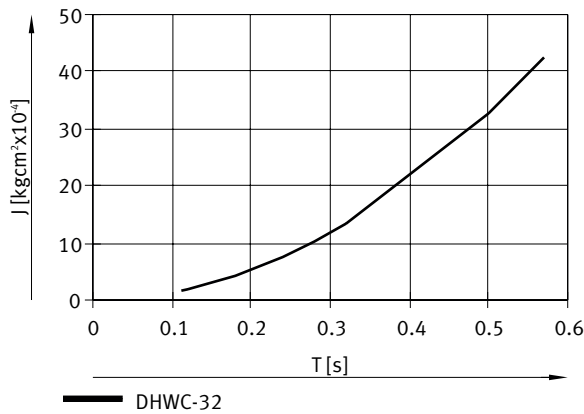

## Dimensions

Dimensions – DHWC-6

Download CAD data [www.festo.com](http://www.festo.com)

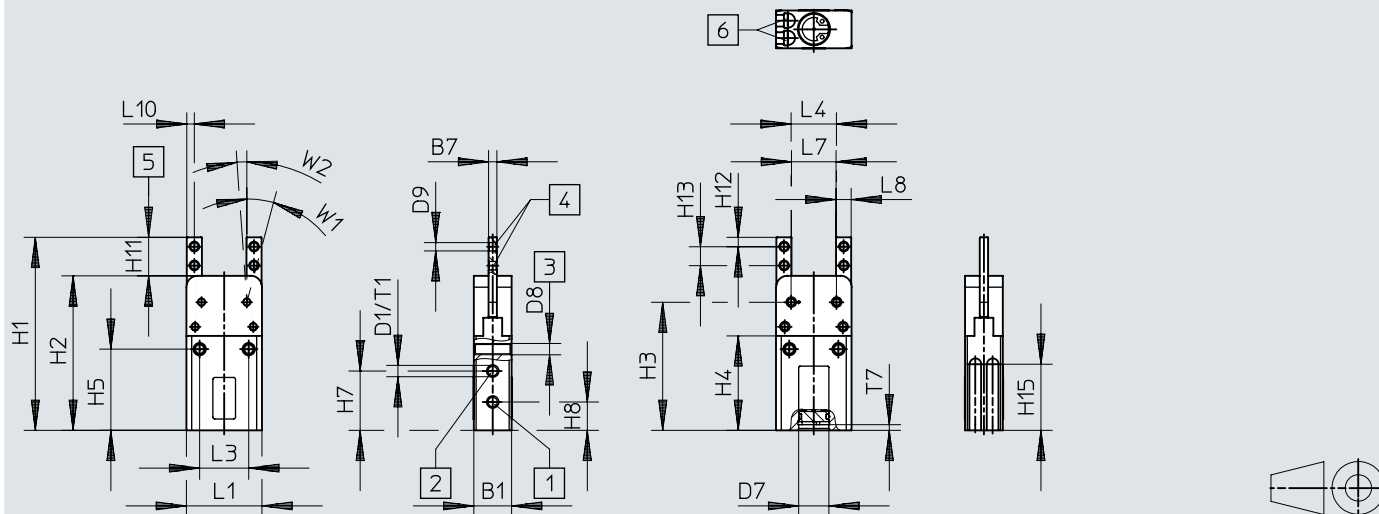

- [1] Open pneumatic connection
- [2] Close pneumatic connection
- [3] Threaded hole for mounting the gripper
- [4] Hole for mounting gripper fingers
- [5] Area for mounting gripper fingers
- [6] C-slot for proximity switch

|          |      |                |      |         |    |                     |      |      |                  |     |      |      |     |      |
|----------|------|----------------|------|---------|----|---------------------|------|------|------------------|-----|------|------|-----|------|
|          | B1   | B7             | D1   | D7      | D8 | D9                  | H1   | H2   | H3               | H4  | H5   | H7   | H8  | H11  |
|          | +0,3 | -0,01<br>-0,05 |      | ∅<br>H8 |    | ∅                   |      |      |                  |     |      |      |     | -0,2 |
| DHWC-6-A | 10   | 2,2            | M3   | 8       | M3 | 2,2 <sup>+0,1</sup> | 51,1 | 40,9 | 33,9             | 25  | 21,5 | 15,7 | 7,5 | 10,2 |
|          | H12  | H13            | H15  | L1      | L3 | L4                  | L7   | L8   | L10              | T1  | T7   | W1   | W2  |      |
|          | -0,2 |                |      | +0,3    |    |                     | -0,4 | -0,4 | +0,025<br>-0,225 |     |      | ±2°  | +3° |      |
| DHWC-6-A | 2,5  | 5              | 17,5 | 20      | 13 | 12                  | 11,8 | 4    | 2                | 4,5 | 1,5  | 15°  | 2°  |      |

Dimensions

Dimensions – DHWC-10 ... 32

Download CAD data [www.festo.com](http://www.festo.com)

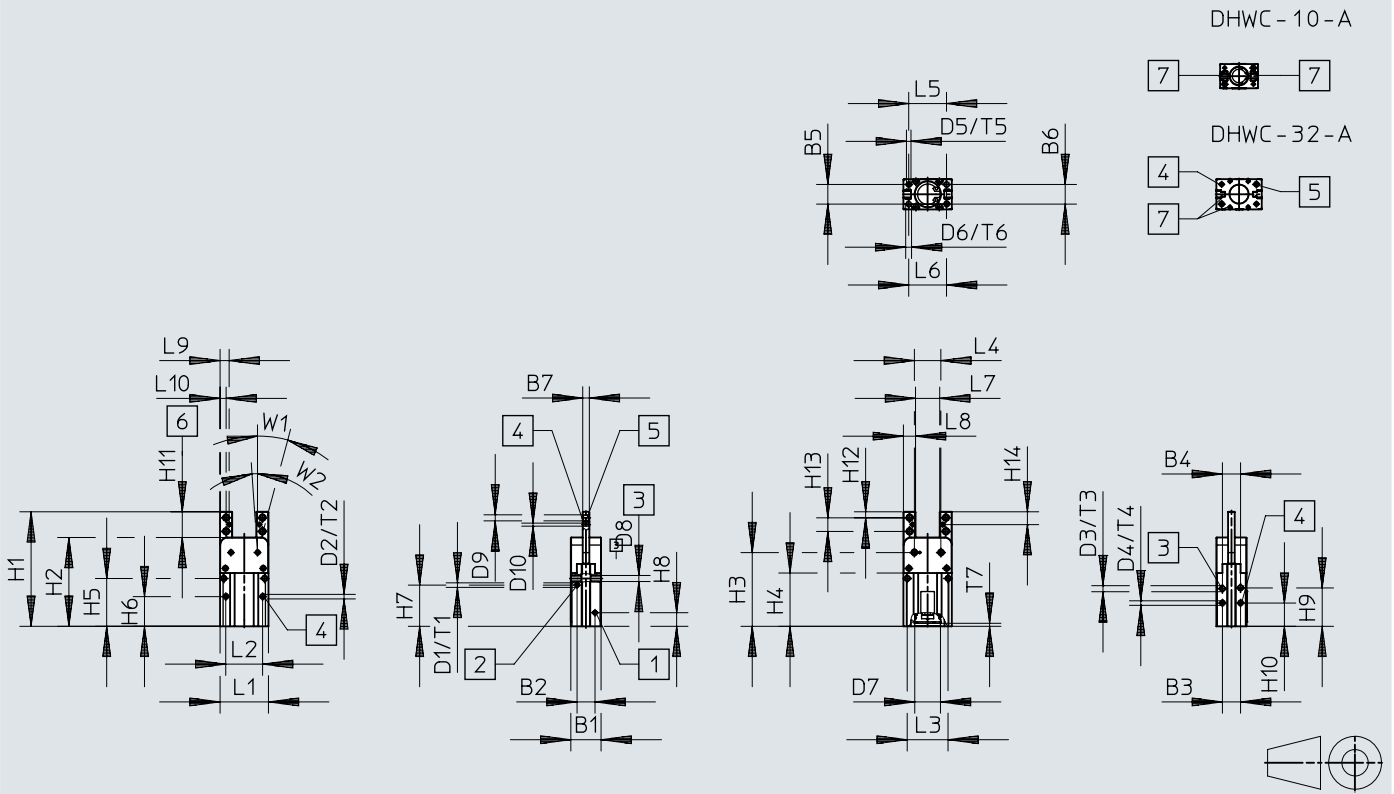

- [1] Open pneumatic connection
- [2] Close pneumatic connection
- [3] Threaded hole for mounting the gripper
- [4] Centring hole
- [5] Threaded hole for mounting gripper fingers
- [6] Area for mounting gripper fingers
- [7] DHWC-10: T-slot for proximity switches, DHWC-16 ... 32: Round slot and T-slot for proximity switches

## Dimensions

|                | B1<br>+0,3 | B2   | B3<br>±0,02 | B4   | B5   | B6<br>±0,02 | B7<br>-0,01<br>-0,05 | D1 | D2<br>∅<br>H9 | D3 | D4<br>∅<br>H9 | D5<br>∅<br>H9 | D6 | D7<br>∅<br>H8 | D8 | D9                  | D10<br>∅<br>+0,02 |
|----------------|------------|------|-------------|------|------|-------------|----------------------|----|---------------|----|---------------|---------------|----|---------------|----|---------------------|-------------------|
| DHWC-10-A      | 16         | 10,8 | 10,8        | 10,8 | 10,8 | 10,8        | 3                    | M3 | 2             | M3 | 2             | 2             | M3 | 12            | M3 | 3,2 <sup>+0,1</sup> | 2                 |
| DHWC-10-A-S-NO |            |      |             |      |      |             |                      |    |               |    |               |               |    |               |    |                     |                   |
| DHWC-16-A      | 20         | 11,9 | 12          | 12   | 13   | 13          | 4,4                  | M3 | 3             | M4 | 3             | 3             | M4 | 17            | M4 | M4                  | 3                 |
| DHWC-16-A-S-NO |            |      |             |      |      |             |                      |    |               |    |               |               |    |               |    |                     |                   |
| DHWC-20-A      | 26         | 15,6 | 16          | 14   | 16,6 | 17          | 5,6                  | M5 | 4             | M5 | 4             | 4             | M5 | 21            | M5 | M5                  | 3                 |
| DHWC-20-A-S-NO |            |      |             |      |      |             |                      |    |               |    |               |               |    |               |    |                     |                   |
| DHWC-25-A      | 33         | 20,4 | 21          | 21   | 20   | 20          | 6,6                  | M5 | 4             | M6 | 5             | 5             | M6 | 26            | M6 | M5                  | 3                 |
| DHWC-25-A-S-NO |            |      |             |      |      |             |                      |    |               |    |               |               |    |               |    |                     |                   |
| DHWC-32-A      | 40         | 24   | 26          | 26   | 26   | 26          | 8,6                  | M5 | 5             | M6 | 5             | 5             | M6 | 25            | M6 | M6                  | 3                 |
| DHWC-32-A-S-NO |            |      |             |      |      |             |                      |    |               |    |               |               |    |               |    |                     |                   |

|                | H1    | H2   | H3   | H4   | H5   | H6<br>+0,1 | H7   | H8   | H9   | H10<br>+0,1 | H11<br>-0,2 | H12<br>-0,2 | H13 | H14<br>-0,2 | L1<br>+0,3 | L2<br>±0,02 | L3   |
|----------------|-------|------|------|------|------|------------|------|------|------|-------------|-------------|-------------|-----|-------------|------------|-------------|------|
| DHWC-10-A      | 62,4  | 46,8 | 38,1 | -    | 21,6 | 11,6       | 15,6 | 7    | 16,1 | 8,5         | 15,6        | 3,5         | 8,6 | 7,8         | 25         | 18          | 18,6 |
| DHWC-10-A-S-NO | 68,3  | 52,7 | 44   |      | 27,5 | 17,5       | 21,5 |      | 22   | 14,4        |             |             |     |             |            |             |      |
| DHWC-16-A      | 75,8  | 58,8 | 48,8 | 35,3 | 31,7 | 19,7       | 27,3 | 9    | 25,4 | 15,4        | 17          | 4           | 9   | 8,5         | 32         | 24,4        | 27   |
| DHWC-16-A-S-NO |       |      |      |      |      |            |      |      |      |             |             |             |     |             |            |             |      |
| DHWC-20-A      | 87,4  | 68,4 | 55,9 | 39,9 | 35,9 | 21,9       | 30   | 10,2 | 28,8 | 16,8        | 19          | 5           | 9   | 9,5         | 40         | 28,4        | 31,6 |
| DHWC-20-A-S-NO |       |      |      |      |      |            |      |      |      |             |             |             |     |             |            |             |      |
| DHWC-25-A      | 103,2 | 80,2 | 65   | 46,2 | 41,5 | 25,8       | 34,5 | 10,5 | 32,9 | 20,9        | 23          | 5,5         | 12  | 11,5        | 50         | 37,2        | 37,4 |
| DHWC-25-A-S-NO |       |      |      |      |      |            |      |      |      |             |             |             |     |             |            |             |      |
| DHWC-32-A      | 117   | 89,3 | 69,3 | 46,7 | 42,2 | 25,2       | 34,2 | 11   | 33,2 | 20,2        | 27,7        | 6           | 16  | 14          | 60         | 46          | 46   |
| DHWC-32-A-S-NO |       |      |      |      |      |            |      |      |      |             |             |             |     |             |            |             |      |

|                | L4   | L5<br>±0,02 | L6 | L7<br>-0,4 | L8<br>-0,4 | L9<br>+0,025<br>-0,225 | L10<br>-0,2 | T1  | T2 | T3  | T4 | T5 | T6 | T7  | W1<br>±2° | W2<br>+3° |
|----------------|------|-------------|----|------------|------------|------------------------|-------------|-----|----|-----|----|----|----|-----|-----------|-----------|
| DHWC-10-A      | 14   | 19          | 19 | 13         | 6          | 3                      | 3           | 4   | 3  | 4   | 3  | 3  | 4  | 1,5 | 15°       | 2°        |
| DHWC-10-A-S-NO |      |             |    |            |            |                        |             |     |    |     |    |    |    |     |           |           |
| DHWC-16-A      | 17,6 | 25          | 25 | 16         | 8          | 6                      | 4           | 4,5 | 3  | 4,5 | 3  | 3  | 6  | 2   | 15°       | 2°        |
| DHWC-16-A-S-NO |      |             |    |            |            |                        |             |     |    |     |    |    |    |     |           |           |
| DHWC-20-A      | 24,8 | 31          | 30 | 22         | 9          | 6                      | 4,5         | 6   | 4  | 8   | 4  | 4  | 10 | 2   | 15°       | 2°        |
| DHWC-20-A-S-NO |      |             |    |            |            |                        |             |     |    |     |    |    |    |     |           |           |
| DHWC-25-A      | 31   | 38          | 38 | 30         | 10         | 5                      | 5           | 7,5 | 4  | 10  | 4  | 4  | 12 | 2   | 15°       | 2°        |
| DHWC-25-A-S-NO |      |             |    |            |            |                        |             |     |    |     |    |    |    |     |           |           |
| DHWC-32-A      | 38   | 46          | 46 | 36         | 12         | 6                      | 6           | 7,5 | 5  | 10  | 5  | 5  | 13 | 2   | 15°       | 2°        |
| DHWC-32-A-S-NO |      |             |    |            |            |                        |             |     |    |     |    |    |    |     |           |           |

Ordering data

| DHWC-6-...   |      |                     |                |          |          |
|--|------|---------------------|----------------|----------|----------|
|  | Size | Mode of operation   | Product weight | Part no. | Type     |
|  | 6    | Double-acting       | 22 g           | 8125286  | DHWC-6-A |
|  |      | Single-acting, Open |                |          |          |

| DHWC-10-...  |      |                     |                |          |                |
|--|------|---------------------|----------------|----------|----------------|
|  | Size | Mode of operation   | Product weight | Part no. | Type           |
|  | 10   | Double-acting       | 48 g           | 8125481  | DHWC-10-A      |
|  |      | Single-acting, Open | 53.5 g         | 8133476  | DHWC-10-A-S-NO |

| DHWC-16 ... 32-... |      |                     |                |          |                |
|--------------------|------|---------------------|----------------|----------|----------------|
|                    | Size | Mode of operation   | Product weight | Part no. | Type           |
|                    | 16   | Double-acting       | 97 g           | 8128711  | DHWC-16-A      |
|                    |      | Single-acting, Open | 97.5 g         | 8128709  | DHWC-16-A-S-NO |
|                    | 20   | Double-acting       | 189.3 g        | 8128701  | DHWC-20-A      |
|                    |      | Single-acting, Open | 190.5 g        | 8128702  | DHWC-20-A-S-NO |
|                    | 25   | Double-acting       | 362 g          | 8128136  | DHWC-25-A      |
|                    |      | Single-acting, Open | 363.5 g        | 8133477  | DHWC-25-A-S-NO |
|                    | 32   | Double-acting       | 639 g          | 8128105  | DHWC-32-A      |
|                    |      | Single-acting, Open | 642 g          | 8133475  | DHWC-32-A-S-NO |

## Peripherals

Size: 6

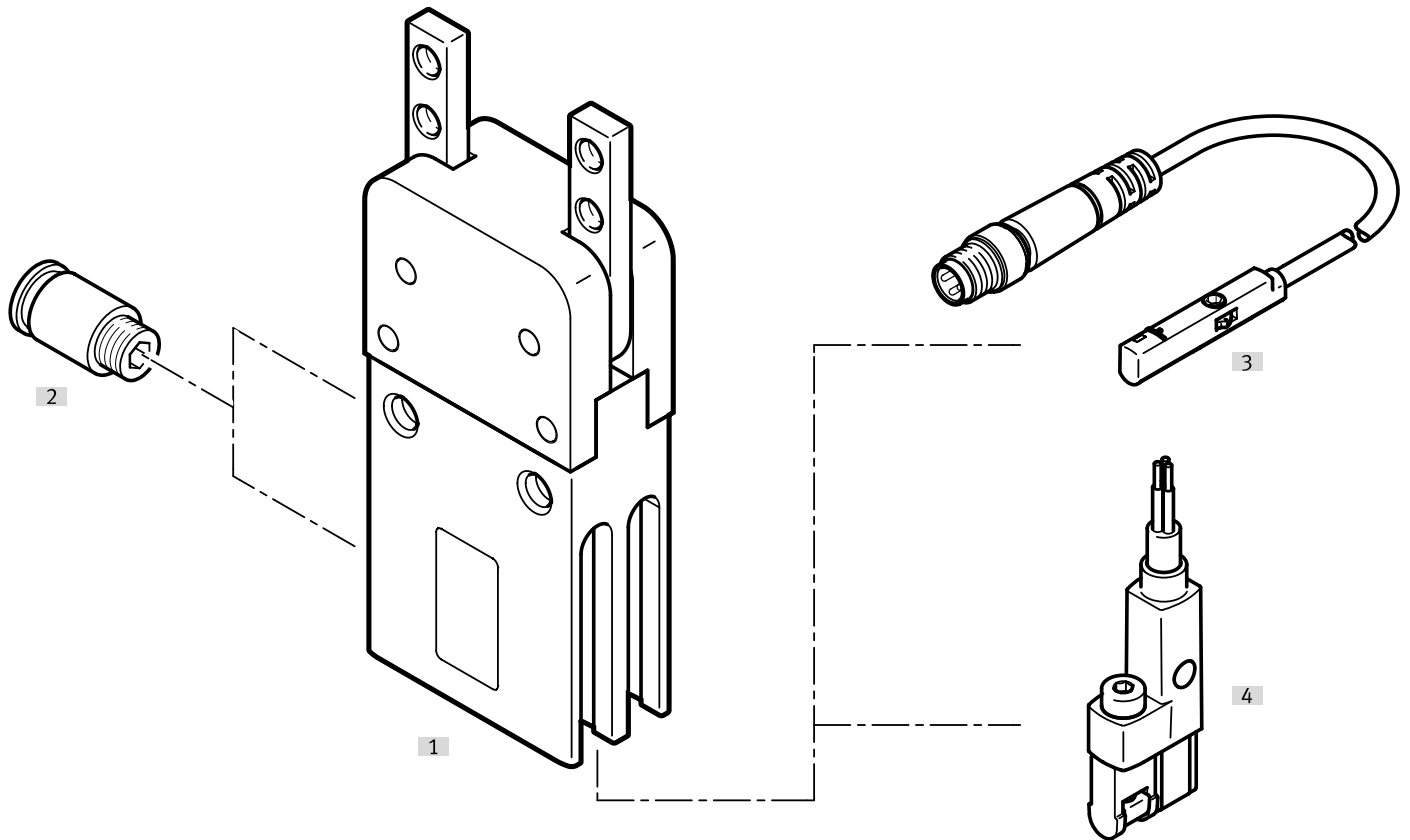

| Accessories                  |  |  | → Link               |
|------------------------------|--|--|----------------------|
| Type/order code              | Description  |  |                      |
| [1] Angle grippers DHWC      | Double-acting or single-acting                       |  | <a href="#">dhwc</a> |
| [2] Push-in fitting QS       | For connecting tubing with standard O.D.             |  | <a href="#">qs</a>   |
| [3] Proximity switch SMT-10M | For sensing the piston position in the end positions |  | <a href="#">26</a>   |
| [4] Proximity switch SMT-10G | For sensing the piston position in the end positions |  | <a href="#">26</a>   |

Peripherals

Size 10

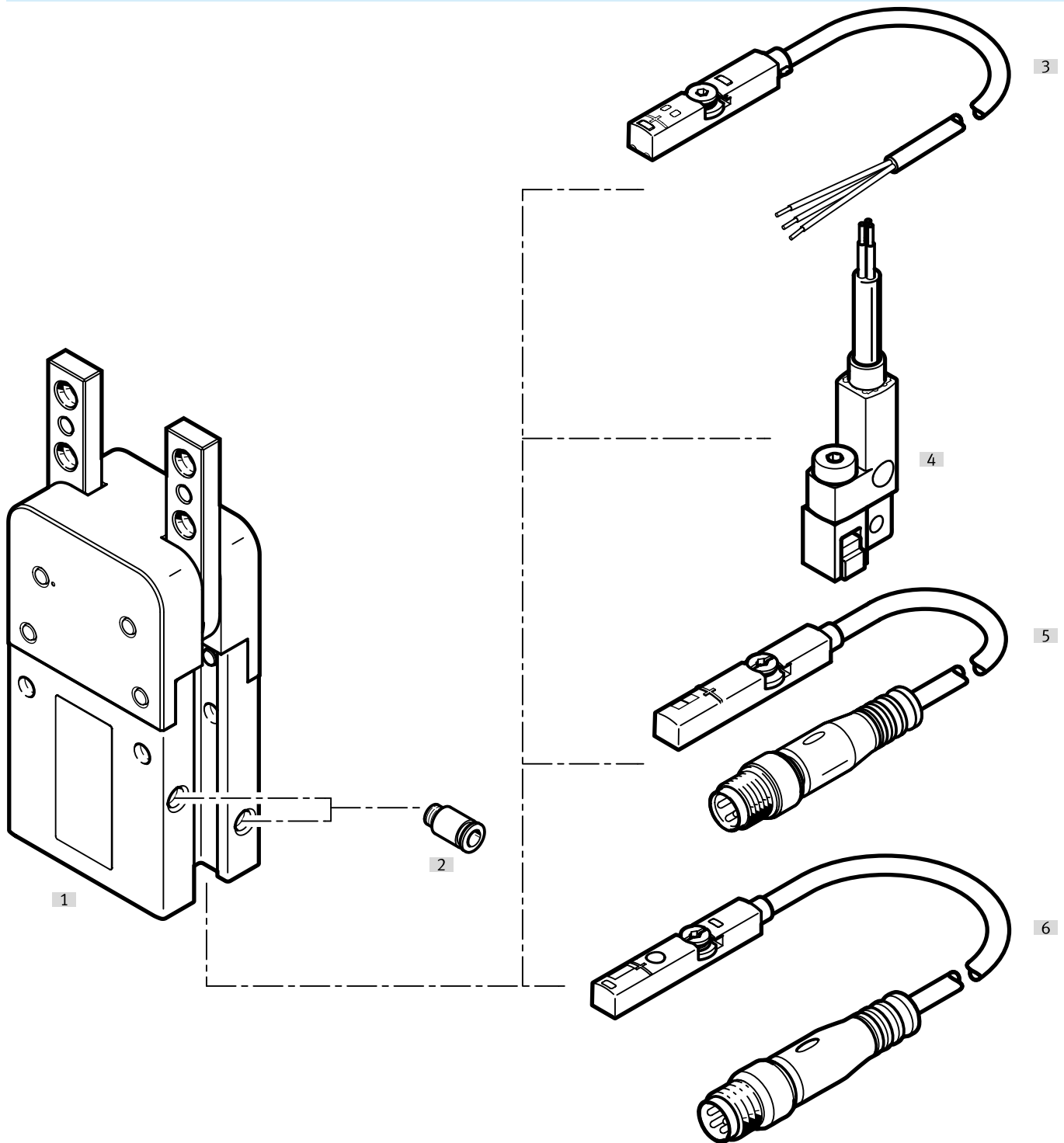

| Accessories                       |  |  | → Link               |
|-----------------------------------|--|--|----------------------|
| Type/order code                   | Description  |  |                      |
| [1] Angle grippers DHWC           | Double-acting  |  | <a href="#">dhwc</a> |
| [2] Push-in fitting QS            | For connecting tubing with standard O.D              |  | <a href="#">qs</a>   |
| [3] Proximity switch SMT-8M       | For sensing the piston position in the end positions |  | <a href="#">26</a>   |
| [4] Proximity switch SMT-8G       | For sensing the piston position in the end positions |  | <a href="#">26</a>   |
| [5] Position transmitter SMAT-8M  | For sensing the piston position at any point         |  | <a href="#">27</a>   |
| [6] Position transmitter SDAS-MHS | For sensing the piston position at any point         |  | <a href="#">27</a>   |



## Peripherals

Size 16 ... 32

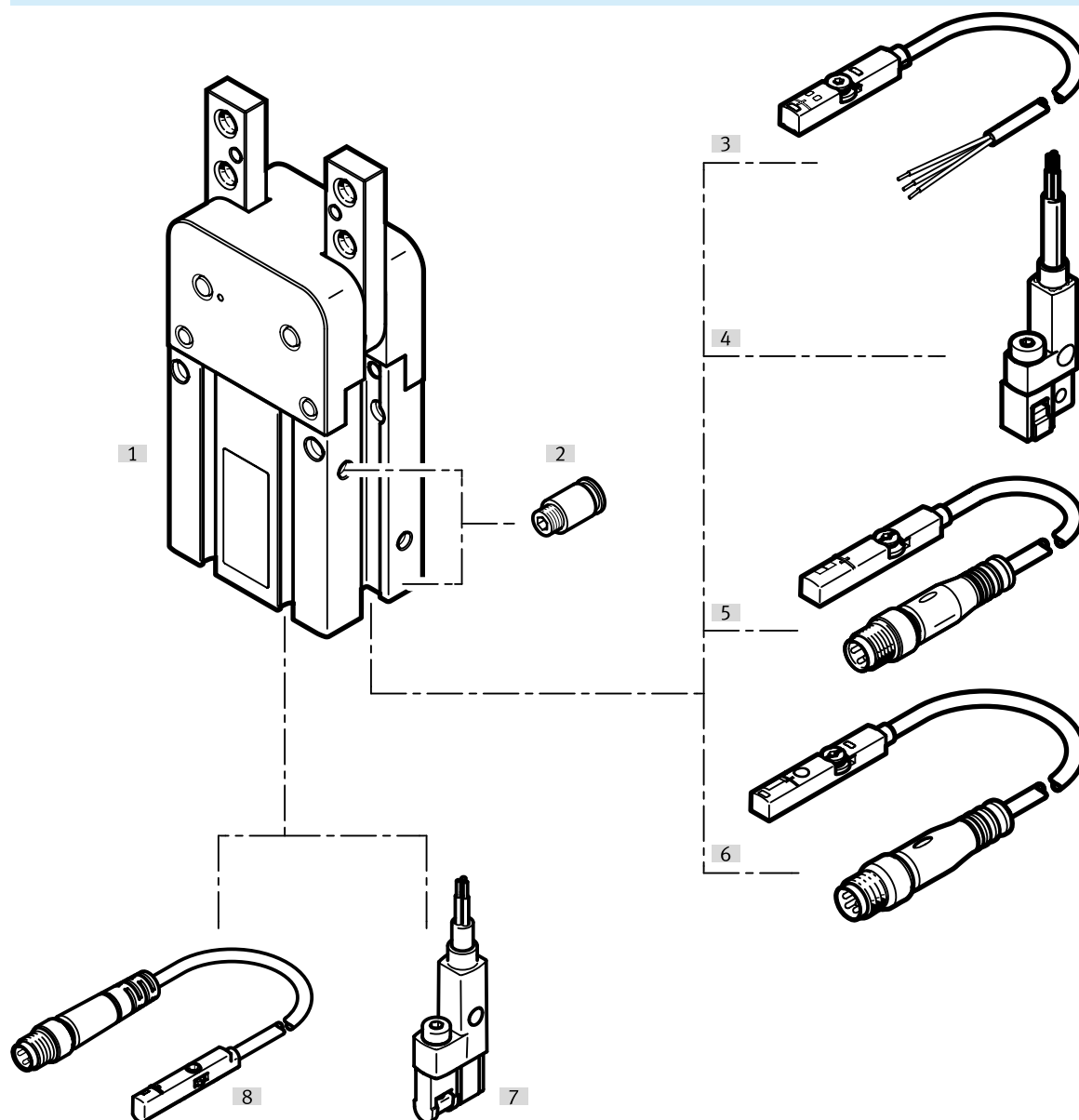

| Accessories                       |  |  | → Link               |
|-----------------------------------|--|--|----------------------|
| Type/order code                   | Description  |  |                      |
| [1] Angle grippers DHWC           | Double-acting or single-acting                       |  | <a href="#">dhwc</a> |
| [2] Push-in fitting QS            | For connecting tubing with standard O.D              |  | <a href="#">qs</a>   |
| [3] Proximity switch SMT-8M       | For sensing the piston position in the end positions |  | <a href="#">26</a>   |
| [4] Proximity switch SMT-8G       | For sensing the piston position in the end positions |  | <a href="#">26</a>   |
| [5] Position transmitter SMAT-8M  | For sensing the piston position at any point         |  | <a href="#">27</a>   |
| [6] Position transmitter SDAS-MHS | For sensing the piston position at any point         |  | <a href="#">27</a>   |
| [7] Proximity switch SMT-10G      | For sensing the piston position in the end positions |  | <a href="#">26</a>   |
| [8] Proximity switch SMT-10M      | For sensing the piston position in the end positions |  | <a href="#">26</a>   |

Accessories

**Proximity switch SMT-10M for round slot, magneto-resistive – for sizes 6, 16 ... 32** Link [smt](#)

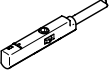
|  | Type of mounting                                 | Switching output       | Electrical connection | Cable length | Part no. | Type                       |
|--|--|------------------------|-----------------------|--------------|----------|----------------------------|
|  | Screw-clamped, Insertable in the slot from above | 3-wire PNP N/O contact | Open end              | 2.5 m        | 551374   | SMT-10M-PS-24V-E-2,5-Q-OE  |
|  |  |                        | Plug M8, A-coded      | 0.3 m        | 551373   | SMT-10M-PS-24V-E-2,5-L-OE  |
|  |  | 3-wire PNP N/O contact | Open end              | 2.5 m        | 551375   | SMT-10M-PS-24V-E-0,3-L-M8D |
|  |  |                        | Plug M8, A-coded      | 0.3 m        | 551376   | SMT-10M-PS-24V-E-0,3-Q-M8D |

**Proximity switch SMT-10G for round slot, magneto-resistive – for sizes 6, 16 ... 32** Link [smt](#)

|  | Type of mounting                                     | Switching output       | Electrical connection | Cable length | Part no. | Type                      |
|--|--|------------------------|-----------------------|--------------|----------|---------------------------|
|  | Clamped in C-slot, Insertable in the slot lengthwise | 3-wire NPN N/O contact | Open end              | 2.5 m        | 8065030  | SMT-10G-NS-24V-E-2,5Q-OE  |
|  |  |                        | Plug M8, A-coded      | 0.3 m        | 8065029  | SMT-10G-NS-24V-E-0,3Q-M8D |
|  |  | 3-wire PNP N/O contact | Open end              | 2.5 m        | 547862   | SMT-10G-PS-24V-E-2,5Q-OE  |
|  |  |                        | Plug M8, A-coded      | 0.3 m        | 547863   | SMT-10G-PS-24V-E-0,3Q-M8D |

**Proximity switch SMT-8M for T-slot, magneto-resistive – for sizes 10 ... 32** Link [smt](#)

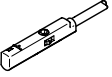
|  | Type of mounting                                 | Switching output       | Electrical connection | Cable length | Part no. | Type                      |
|--|--|------------------------|-----------------------|--------------|----------|---------------------------|
|  | Screw-clamped, Insertable in the slot from above | 3-wire NPN N/O contact | Open end              | 2.5 m        | 574338   | SMT-8M-A-NS-24V-E-2,5-OE  |
|  |  |                        | Plug M8, A-coded      | 0.3 m        | 574339   | SMT-8M-A-NS-24V-E-0,3-M8D |
|  |  | 3-wire PNP N/C contact | Open end              | 7.5 m        | 574340   | SMT-8M-A-PO-24V-E-7,5-OE  |
|  |  |                        | Plug M8, A-coded      | 0.3 m        | 574335   | SMT-8M-A-PS-24V-E-2,5-OE  |
|  |  | 3-wire PNP N/O contact | Open end              | 2.5 m        | 574334   | SMT-8M-A-PS-24V-E-0,3-M8D |
|  |  |                        | Plug M12, A-coded     | 0.3 m        | 574337   | SMT-8M-A-PS-24V-E-0,3-M12 |

**Proximity switch SMT-8G for T-slot, magneto-resistive – for sizes 10 ... 32** Link [smt](#)

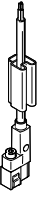
|  | Type of mounting                                     | Switching output       | Electrical connection | Cable length | Part no. | Type                     |
|--|--|------------------------|-----------------------|--------------|----------|--------------------------|
|  | Clamped in T-slot, Insertable in the slot lengthwise | 3-wire NPN N/O contact | Open end              | 2.5 m        | 8065028  | SMT-8G-NS-24V-E-2,5Q-OE  |
|  |  |                        | Plug M8, A-coded      | 0.3 m        | 8065027  | SMT-8G-NS-24V-E-0,3Q-M8D |
|  |  | 3-wire PNP N/O contact | Open end              | 2.5 m        | 547859   | SMT-8G-PS-24V-E-2,5Q-OE  |
|  |  |                        | Plug M8, A-coded      | 0.3 m        | 547860   | SMT-8G-PS-24V-E-0,3Q-M8D |

**Connecting cable NEBU, straight, connection M8**

|  | Electrical connection 1, connector system | Electrical connection 2, connector system | Electrical connection 2, number of connections/cores | Cable length | Part no. | Type                |
|--|---|---|--|--------------|----------|---------------------|
|  | M8x1, A-coded, to EN 61076-2-104          | Open end                                  | 3  | 2.5 m        | 541333   | NEBU-M8G3-K-2.5-LE3 |
|  |   |   |  | 5 m          | 541334   | NEBU-M8G3-K-5-LE3   |

## Accessories

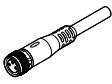
| Connecting cable NEBU, straight, connection M12                                   |   |   |  |              |          |                      |
|---|---|---|--|--------------|----------|----------------------|
|   | Electrical connection 1, connector system | Electrical connection 2, connector system | Electrical connection 2, number of connections/cores | Cable length | Part no. | Type                 |
|  | M12x1, A-coded to EN 61076-2-101          | Open end                                  | 3  | 2.5 m        | 541363   | NEBU-M12G5-K-2.5-LE3 |
|   |   |   |  | 5 m          | 541364   | NEBU-M12G5-K-5-LE3   |

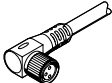
| Connecting cable NEBU, angled, connection M8                                      |   |   |  |              |          |                     |
|---|---|---|--|--------------|----------|---------------------|
|   | Electrical connection 1, connector system | Electrical connection 2, connector system | Electrical connection 2, number of connections/cores | Cable length | Part no. | Type                |
|  | M8x1, A-coded, to EN 61076-2-104          | Open end                                  | 3  | 2.5 m        | 541338   | NEBU-M8W3-K-2.5-LE3 |
|   |   |   |  | 5 m          | 541341   | NEBU-M8W3-K-5-LE3   |

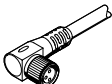
| Connecting cable NEBU, angled, connection M12                                       |   |   |  |              |          |                      |
|---|---|---|--|--------------|----------|----------------------|
|   | Electrical connection 1, connector system | Electrical connection 2, connector system | Electrical connection 2, number of connections/cores | Cable length | Part no. | Type                 |
|  | M12x1, A-coded to EN 61076-2-101          | Open end                                  | 3  | 2.5 m        | 541367   | NEBU-M12W5-K-2.5-LE3 |
|   |   |   |  | 5 m          | 541370   | NEBU-M12W5-K-5-LE3   |

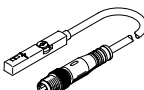
| Position transmitter SMAT-8M for T-slot, plug M8, A-coded – for size 10 ... 32 <span style="float: right;">Link <a href="#">smat</a></span> |               |                 |  |              |          |                     |
|---|---------------|-----------------|--|--------------|----------|---------------------|
|   | Sensing range | Analogue output | Electrical connection 1, number of connections/cores | Cable length | Part no. | Type                |
|    | 52 mm         | 0 - 10 V        | 4  | 0.3 m        | 553744   | SMAT-8M-U-E-0,3-M8D |

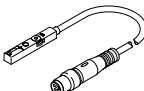
| Position transmitter SDAS for T-slot, M8 plug, A-coded – for size 10 ... 32 <span style="float: right;">Link <a href="#">sdas</a></span> |   |               |  |              |          |                                  |
|--|---|---------------|--|--------------|----------|----------------------------------|
|  | Description   | Sensing range | Electrical connection 1, number of connections/cores | Cable length | Part no. | Type                             |
|   | Operating modes: two adjustable switching outputs; IO-Link® | 52 mm         | 4  | 0.3 m        | 8063974  | SDAS-MHS-M40-1L-PNLK-PN-E-0.3-M8 |
|  |   |               |  | 2.5 m        | 8063975  | SDAS-MHS-M40-1L-PNLK-PN-E-2.5-LE |

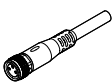
| Connecting cables NEBU, straight  |   |   |  |              |          |                     |
|---|---|---|--|--------------|----------|---------------------|
|   | Electrical connection 1, connector system | Electrical connection 2, connector system | Electrical connection 2, number of connections/cores | Cable length | Part no. | Type                |
|  | M8x1, A-coded, to EN 61076-2-104          | Open end                                  | 4  | 2.5 m        | 541342   | NEBU-M8G4-K-2.5-LE4 |

Accessories

Connecting cables NEBU, straight

|  | Electrical connection 1, connector system | Electrical connection 2, connector system | Electrical connection 2, number of connections/cores | Cable length | Part no.      | Type                     |
|--|---|---|--|--------------|---------------|--------------------------|
|  | M8x1, A-coded, to EN 61076-2-104          | Open end                                  | 4  | 5 m          | <b>541343</b> | <b>NEBU-M8G4-K-5-LE4</b> |

Connecting cables NEBU, angled

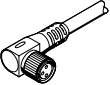
|  | Electrical connection 1, connector system | Electrical connection 2, connector system | Electrical connection 2, number of connections/cores | Cable length | Part no.      | Type                       |
|--|---|---|--|--------------|---------------|----------------------------|
|  | M8x1, A-coded, to EN 61076-2-104          | Open end                                  | 4  | 2.5 m        | <b>541344</b> | <b>NEBU-M8W4-K-2.5-LE4</b> |
|  |   |   |  | 5 m          | <b>541345</b> | <b>NEBU-M8W4-K-5-LE4</b>   |