

DSBC

Standards-based cylinder

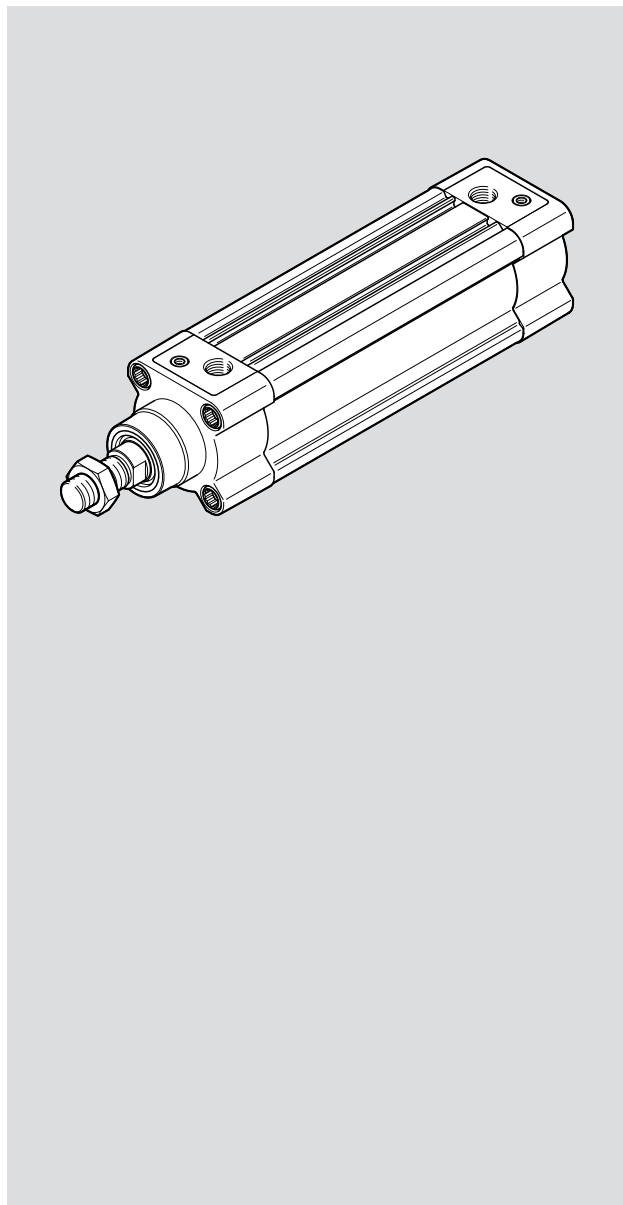

FESTO

Operating instruc-
tion



8189606

8189606
2023-11
[8189608]

Translation of the original instructions

Table of contents

1	Applicable documents	4
2	Safety	4
	2.1 Safety instructions.....	4
	2.2 Intended use.....	4
	2.3 Training of qualified personnel.....	4
3	Additional information	4
4	Product overview	5
	4.1 Product design.....	5
	4.2 Function.....	5
5	Assembly	5
	5.1 Mounting standards-based cylinder.....	5
	5.2 Mounting the payload.....	6
	5.3 Mounting accessories.....	7
6	Installation	8
7	Commissioning	8
8	Cleaning	8
9	Fault clearance	8
10	Technical data	9
	10.1 Technical data, general.....	9
	10.2 Technical data, pneumatic.....	11

1 Applicable documents



All available documents for the product → www.festo.com/sp.

2 Safety

2.1 Safety instructions

- Only use the product in its original condition without unauthorised modifications.
- Observe the identifications on the product.
- Take into account the ambient conditions at the location of use.
- Store the product in a cool, dry environment protected from UV and corrosion. Keep storage times short.
- Before working on the product, switch off the compressed air supply and lock it to prevent it from being switched on again.

2.2 Intended use

The standards-based cylinder moves masses and transmits forces. The product is intended for use in industrial environments.

2.3 Training of qualified personnel

Work on the product may only be carried out by qualified personnel who can evaluate the work and detect dangers. The qualified personnel have knowledge and experience in pneumatics.

3 Additional information

- Contact the regional Festo contact if you have technical problems → www.festo.com.
- Accessories and spare parts → www.festo.com/catalogue.

4 Product overview

4.1 Product design

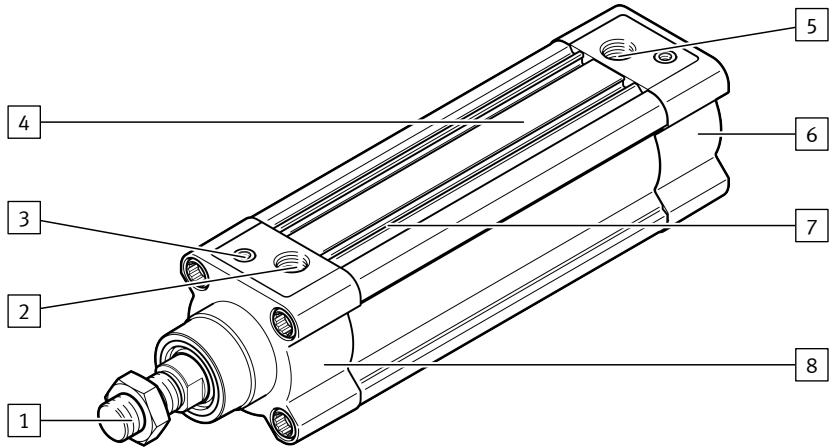

Fig. 1: Standards-based cylinder DSBC

- | | |
|--|--|
| <ul style="list-style-type: none"> 1 Thread for mounting the payload 2 Pneumatic port 1 3 For DSBC-...-PPV:
Adjustable end-position cushioning (2x) 4 Cylinder barrel 5 Pneumatic port 2 | <ul style="list-style-type: none"> 6 End cap,
with mounting option,
female thread 7 Slot for proximity switch 8 Bearing cap,
with mounting option,
female thread |
|--|--|

4.2 Function

When the cylinder chamber is pressurised at pneumatic port 1 or 2, the piston rod moves outwards or inwards. The cylinder force varies during advance and retraction. The position of the piston can be queried by proximity switches.

5 Assembly

5.1 Mounting standards-based cylinder

Requirement:

- The product is installed without tension.

A rigid coupling will reduce the service life and adversely affect the function of the cylinder.

DSBC	-32	-40	-50	-63
Thread	M6		M8	
Screw-in depth [mm]	11 ... 16			

DSBC	-32	-40	-50	-63
Screw strength	≥ A*-70			
	≥ 8.8			
Flange thickness Aluminium, steel	≥ 5.5		≥ 6.5	
Tightening torque [Nm]	5 ± 20 %		8 ± 20 %	

Tab. 1: Tightening torques DSBC-32 ... -63

DSBC	-80	-100	-125
Thread	M10		M12
Screw-in depth [mm]	7 ... 17		10 ... 20
Screw strength	≥ A*-70		
	≥ 8.8		
Flange thickness Aluminium, steel	≥ 10		
Tightening torque [Nm]	17 ± 20 %		25 ± 20 %

Tab. 2: Tightening torques DSBC-80 ... -125

1. Mount the standards-based cylinder with at least 4 screws. Observe the tightening torque.
2. Avoid mechanical misalignment between the piston rod, for example in connection with an external guide, with one of the following measures:
 - Precise alignment
 - Use of attachments with ball bearings, e.g. rod eye, swivel flange
 - Use of a self-aligning rod coupler
 - Use of a guide unit

5.2 Mounting the payload

Requirement:

- An adequately sized intercepting device is used for medium and large payloads or at high speeds.
- Suitable shock absorbers or external stops are fitted with maximum payload, maximum piston speed or when using quick exhaust valves.

DSBC	-32	-40	-50	-63
Thread	M10x1.25	M12x1.25	M16x1.5	
Hex nut	ISO 8675-...-04			
	ISO 8675-...-035			
Max. tightening torque [Nm]	20	35	85	

Tab. 3: Maximum tightening torque DSBC-32 ... -63

DSBC	-80	-100	-125
Thread	M20x1.5		M27x2
Hex nut	ISO 8675-...-04		
	ISO 8675-...-035		ISO 8675-...-025
Max. tightening torque [Nm]	170		310

Tab. 4: Maximum tightening torque DSBC-80 ... -125

i

For DSBC-...-S2: do not counter-rotate the through piston rod by the spanner flats. This may disconnect the piston rod connection from the piston.

DSBC-...-F	-32	-40	-50	-63
Thread	M6	M8	M10	
Screw-in depth	7 ... 12		11 ... 16	
Max. tightening torque for screws in strength class ≥ 10.9 [Nm]	10		28	
Max. tightening torque for screws in strength class ≥ A*-70 [Nm]	6	8	25	

Tab. 5: Maximum tightening torque DSBC-32 ... -63-F

DSBC-...-F	-80	-100	-125
Thread	M12		M16
Screw-in depth	13 ... 20		22 ... 32
Max. tightening torque for screws in strength class ≥ 10.9 [Nm]	45		120
Max. tightening torque for screws in strength class ≥ A*-70 [Nm]	35		100

Tab. 6: Maximum tightening torque DSBC-80 ... -125-F

- Mount the payload by the thread. Observe the maximum tightening torque.

5.3 Mounting accessories

1. To adjust the speed: screw the one-way flow control valves into the pneumatic ports.
2. With DSBC-...-A: use proximity switches. Avoid external influence caused by magnetic or ferritic parts in the vicinity of the proximity switches. Minimum distance: 10 mm

6 Installation

- Connect tubing to the pneumatic ports.

7 Commissioning

1. Screw the one-way flow control valves all the way in on both sides, then back one revolution.
2. With DSBC-...-PPV: screw in the adjustable end-position cushioning on both sides to fully closed, then unscrew by one turn.
3. Pressurise the cylinder simultaneously on both port sides.
 - ↳ The piston rod slowly extends to the end position.
4. Exhaust the cylinder on one side.
 - ↳ The piston rod moves to the end position.
5. Start the test run.
6. If necessary: adjust the speed at the one-way flow control valves and the adjustable end-position cushioning. The piston rod should reach the end stop without hard impact or rebounding.

8 Cleaning

- Clean the product with a clean, soft cloth and non-abrasive cleaning agents.

9 Fault clearance

Malfunction	Cause	Remedy
Irregular motion of the piston rod.	The one-way flow control valves throttle the exhaust air too much.	– Reduce exhaust air throttling.
	The adjustable end-position cushioning is set too high.	– Reduce the adjustable end-position cushioning.
	The piston rod is dirty.	– Clean the cylinder.
		– Relubricate after cleaning.
	The supply air is insufficient.	– Install a covering.
		– Keep the tubing short and select large cross sections.
		– Select the correct operating pressure.
The pressure is too low.	– Maintain a constant operating pressure.	
	– Connect a volume upstream.	
	– Increase the pressure.	
The cylinder is damaged.	– Repair or replace the cylinder.	

Malfunction	Cause	Remedy
Irregular motion of the piston rod.	Insufficient lubricant.	– Apply lubricant according to information leaflet → www.festo.com/spareparts
	The guide is not parallel to the direction of stroke.	– Use a self-aligning rod coupler.
Hard stops by the cylinder at the end position	The speed is too high.	– Reduce the exhaust air flow control.
	The cushioning is too low.	– Increase the cushioning. – Use additional cushioning components.
The piston does not move to the end position.	The cylinder is damaged.	– Repair or replace the cylinder.
	The adjustable end-position cushioning is set too high.	– Reduce the adjustable end-position cushioning.
Malfunctions with the position sensing	The temperatures are too high or too low.	– Maintain the permissible temperature range.
	The proximity switches are defective.	– Replace the proximity switches.
	Incorrect proximity switch installed.	– Use suitable proximity switches.
	Magnetic or ferritic components near the proximity switches.	– Increase the distance from the components. – Remove the components.
	The cylinder is in DNC version, without position sensing	– Select the cylinder in DNC-...-A version, with position sensing

Tab. 7: Fault clearance

10 Technical data

10.1 Technical data, general

DSBC	-32	-40	-50	-63
Mounting position	Any			
Operating medium	Compressed air to ISO 8573-1:2010 [7:4:4]			
Information on the operating medium	Lubricated operation possible, in which case lubricated operation will always be required			

Technical data

DSBC	-32	-40	-50	-63
Max. torque on the piston rod				
DSBC-...-Q [Nm]	0.8	1.1	1.5	
Pneumatic port				
DSBC	G 1/8	G 1/4		G 3/8
Max. impact energy at the end positions				
DSBC [J]	0.4 ¹⁾	0.7	1.0	1.3
DSBC-...-L/-T1/-T3/-T4/-U [J]	0.2 ¹⁾	0.35	0.5	0.65
DSBC-...-L1 [J]	0.1	0.2	0.3	0.4
Cushioning				
DSBC-...-P	Elastic cushioning rings/plates on both sides			
DSBC-...-PPV	Pneumatically acting, adjustable end-position cushioning, on both sides			
DSBC-...-PPS	Pneumatically acting, self-adjusting end-position cushioning, on both sides			
Ambient temperature				
DSBC [°C]	-20 ... +80			
DSBC-...-A6/-F1A [°C]	-20 ... +80			
DSBC-...-A1 [°C]	0 ... +80			
DSBC-...-T1/-T1-A6 [°C]	0 ... +120			
DSBC-...-T3/-T3-A6 [°C]	-40 ... +80			
DSBC-...-T4/-T4-A6 [°C]	0 ... +150			
DSBC-...-C/-P2 [°C]	-10 ... +80			
DSBC-...-L/-U [°C]	+5 ... +80			
DSBC-...-L1 [°C]	0 ... +60			

1) In conjunction with the DAMT centre pivot flange DAMT the maximum impact energy is 0.1 J.

Tab. 8: Technical data, general DSBC-32 ... -63

DSBC	-80	-100	-125
Mounting position	Any		
Operating medium	Compressed air to ISO 8573-1:2010 [7:4:4]		
Information on the operating medium	Lubricated operation possible, in which case lubricated operation will always be required		

Technical data

DSBC		-80	-100	-125
Max. torque on the piston rod				
DSBC-...-Q	[Nm]	3		–
Pneumatic port				
DSBC		G 3/8	G 1/2	
Max. impact energy at the end positions				
DSBC	[J]	1.8	2.5	3.3
DSBC-...-L/-T1/-T3/-T4/-U	[J]	0.9	1.25	1.65
DSBC-...-L1	[J]	0.9	1.25	1.65
Cushioning				
DSBC-...-P		Elastic cushioning rings/plates on both sides		
DSBC-...-PPV		Pneumatically acting, adjustable end-position cushioning, on both sides		
DSBC-...-PPS		Pneumatically acting, self-adjusting end-position cushioning, on both sides		
Ambient temperature				
DSBC	[°C]	–20 ... +80		
DSBC-...-A6/-F1A	[°C]	–20 ... +80		
DSBC-...-A1	[°C]	0 ... +80		
DSBC-...-T1/-T1-A6	[°C]	0 ... +120		
DSBC-...-T3/-T3-A6	[°C]	–40 ... +80		
DSBC-...-T4/-T4-A6	[°C]	0 ... +150		
DSBC-...-C/-P2	[°C]	–10 ... +80		
DSBC-...-L/-U	[°C]	+5 ... +80		
DSBC-...-L1	[°C]	0 ... +60		

Tab. 9: Technical data, general DSBC-80 ... 125

10.2 Technical data, pneumatic

DSBC		-32	-40	-50	-63
Operating pressure					
DSBC	[MPa]	0.06 ... 1.2		0.04 ... 1.2	
	[bar]	0.6 ... 12		0.4 ... 12	
	[psi]	8.7 ... 174		5.8 ... 174	

Technical data

DSBC		-32	-40	-50	-63
DSBC-...-F1A	[MPa]	0.06 ... 1.2		0.04 ... 1.2	
	[bar]	0.6 ... 12		0.4 ... 12	
	[psi]	8.7 ... 174		5.8 ... 174	
DSBC-...-D3	[MPa]	0.08 ... 1.2	0.06 ... 1.2		0.04 ... 1.2
	[bar]	0.8 ... 12	0.6 ... 12		0.4 ... 12
	[psi]	11.6 ... 174	8.7 ... 174		5.8 ... 174
DSBC-...-Q	[MPa]	0.1 ... 1.2			
	[bar]	1 ... 12			
	[psi]	14.5 ... 174			
DSBC-...-Q-T1	[MPa]	0.1 ... 0.8			
	[bar]	1 ... 8			
	[psi]	14.5 ... 116			
DSBC-...-T3/-A2	[MPa]	0.1 ... 1.2			
	[bar]	1 ... 12			
	[psi]	14.5 ... 174			
DSBC-...-A3	[MPa]	0.15 ... 1.2		0.1 ... 1.2	0.06 ... 1.2
	[bar]	1.5 ... 12		1 ... 12	0.6 ... 12
	[psi]	21.8 ... 174		14.5 ... 174	8.7 ... 174
DSBC-...-A6/-A6-T3	[MPa]	0.15 ... 1.2			
	[bar]	1.5 ... 12			
	[psi]	21.8 ... 174			
DSBC-...-L/-L1	[MPa]	0.03 ... 1.2	0.025 ... 1.2		
	[bar]	0.3 ... 12	0.25 ... 12		
	[psi]	4.35 ... 174	3.65 ... 174		
DSBC-...-U	[MPa]	0.025 ... 1.2		0.02 ... 1.2	0.015 ... 1.2
	[bar]	0.25 ... 12		0.2 ... 12	0.15 ... 12
	[psi]	3.65 ... 174		2.9 ... 174	2.18 ... 174
DSBC-...-C/-Q-C	[MPa]	0.15 ... 1			
	[bar]	1.5 ... 10			
	[psi]	21.8 ... 145			
DSBC-...-E1/-E2/-E3	[MPa]	0.25 ... 1.2		0.15 ... 1.2	

Technical data

DSBC		-32	-40	-50	-63
DSBC-...-E1/-E2/-E3	[bar]	2.5 ... 12		1.5 ... 12	
	[psi]	36.2 ... 174		21.8 ... 174	

Tab. 10: Technical data, pneumatic DSBC-32 ... -63

DSBC		-80	-100	-125
Operating pressure				
DSBC	[MPa]	0.04 ... 1.2		0.02 ... 1
	[bar]	0.4 ... 12		0.2 ... 10
	[psi]	5.8 ... 174		2.9 ... 145
DSBC-...-F1A	[MPa]	0.04 ... 1.2		0.02 ... 1
	[bar]	0.4 ... 12		0.2 ... 10
	[psi]	5.8 ... 174		2.9 ... 145
DSBC-...-D3	[MPa]	0.04 ... 1.2		0.02 ... 1
	[bar]	0.4 ... 12		0.2 ... 10
	[psi]	5.8 ... 174		2.9 ... 145
DSBC-...-Q	[MPa]	0.1 ... 1.2		–
	[bar]	1 ... 12		–
	[psi]	14.5 ... 174		–
DSBC-...-Q-T1	[MPa]	0.1 ... 0.8		–
	[bar]	1 ... 8		–
	[psi]	14.5 ... 116		–
DSBC-...-T3/-A2	[MPa]	0.1 ... 1.2		0.1 ... 1
	[bar]	1 ... 12		1 ... 10
	[psi]	14.5 ... 174		14.5 ... 145
DSBC-...-A3	[MPa]	0.06 ... 1.2		0.06 ... 1
	[bar]	0.6 ... 12		0.6 ... 10
	[psi]	8.7 ... 174		8.7 ... 145
DSBC-...-A6/-A6-T3	[MPa]	0.15 ... 1.2		0.15 ... 1
	[bar]	1.5 ... 12		1.5 ... 10
	[psi]	21.8 ... 174		21.8 ... 145
DSBC-...-L/-L1	[MPa]	0.02 ... 1.2	0.015 ... 1.2	0.01 ... 1
	[bar]	0.2 ... 12	0.15 ... 12	0.1 ... 10

Technical data

DSBC		-80	-100	-125
DSBC-...-L/-L1	[psi]	2.9 ... 174	2.18 ... 174	1.45 ... 145
DSBC-...-U	[MPa]	0.01 ... 1.2		0.01 ... 1
	[bar]	0.1 ... 12		0.1 ... 10
	[psi]	1.45 ... 174		1.45 ... 145
DSBC-...-C/-Q-C	[MPa]	0.15 ... 1		
	[bar]	1.5 ... 10		
	[psi]	21.8 ... 145		
DSBC-...-E1/-E2/-E3	[MPa]	0.15 ... 1		–
	[bar]	1.5 ... 10		–
	[psi]	21.8 ... 145		–

Tab. 11: Technical data, pneumatic DSBC-80 ... -125

Copyright:
Festo SE & Co. KG
Ruiter Straße 82
73734 Esslingen
Germany

Phone:
+49 711 347-0

Internet:
www.festo.com