

## Calculation aid for cushioning components

**FESTO**

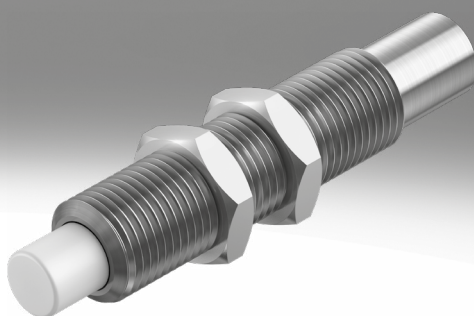

## Data sheet

This selection aid helps you determine the right shock absorber for every application.

When choosing the correct shock absorber, we recommend that you proceed as follows:

When selecting a shock absorber for your application, you must ensure that the following values are not exceeded:

The (angular) speed used in the formula is the speed on impact with the shock absorber. This depends on the dynamic performance of the drive component and can thus only be determined with difficulty.

It is better to determine the average speed ( $v_m = s/t$  or  $\omega_m = \varphi/t$ ).

The following formulas are required for the calculation:

The following applies in addition for rotary motion:

The following abbreviations are used:

1. Determine the following at the moment of impact:

- Force (A)
- Equivalent mass  $m_{equiv}$
- Impact velocity (v)

- Permissible energy utilisation per stroke:

$$W_{min.} = 25\%$$

$$W_{max.} = 100\%$$

- Recommended energy utilisation per stroke:

$$W_{opt.} = 50\% \dots 100\%$$

To prevent damage to the drive, for safety reasons the following values should be used for calculation:

$$v = 1.25 \dots 2 v_m$$

$$\omega = 1.25 \dots 2 \omega_m$$

Typical values for linear movements:

Factor of 2 for strokes < 50 mm,

Factor of 1.5 for strokes > 50 mm and < 100 mm,

Factor of 1.25 for strokes > 100 mm.

$$A = F + G$$

$$A = F + m \times g \times \sin \alpha$$

$$W_{total} = 1/2 \times m \times v^2 + A \times s < W_{max.}$$

$$W_h = W_{total} \times \text{strokes} / \text{hour} < W_{hmax.}$$

$$m_{equiv.} = 1/R^2$$

$$v = w \times R$$

$$A = M/R + m \times g \times \sin \alpha \times a/R$$

A = Additional force = F + G [N]

F = Cylinder force minus frictional force [N]

G = Weight force  
= m x g x sin α

Special cases:

α = 0°: Horizontal movement

$$G = 0$$

α = 90°: Downward movement

$$G = m \times g$$

α = 90°: Upward movement

$$G = -m \times g$$

2. Select the shock absorber from the graphs on the following pages.

3. Check the selected shock absorber using the max. cushioning energy ( $W_{max.}$ )

- Max. energy absorption per hour

- Max. residual energy

- Max. stop force in the end position

As the (angular) speed is squared in the calculation, the expected error increases considerably. The calculation can therefore only be taken into consideration as an approximate figure. However, the safety factor ensures that it is not possible to select a shock absorber that is too small.

v = Impact velocity [m/s]

$m_{equiv.}$  = Equivalent mass [kg]

g = Acceleration due to gravity  
9.81 [m/s<sup>2</sup>]

s = Shock absorber stroke [m]

α = Impact angle [°]

$W_{total}$  = Cushioning work/stroke [J]

$W_h$  = Cushioning work/hour [J]

J = Mass moment of inertia  
[kg x m<sup>2</sup>]

R = Distance between the pivot point of mass and shock absorber [m]

ω = Angular speed [rad/s]

M = Drive torque [Nm]

a = Distance between the centre of gravity of mass and the pivot point

## Data sheet

**Sizing example for linear motion**

The procedure for selecting a shock absorber is illustrated using the adjacent diagram as an example:

$$\begin{aligned}
 A &= F + m \times g \times \sin \alpha \\
 &= 190 \text{ N} + 50 \times 9.81 \times \sin \alpha \\
 &= 537 \text{ N} \\
 m_{\text{equiv.}} &= m = 50 \text{ kg}
 \end{aligned}$$

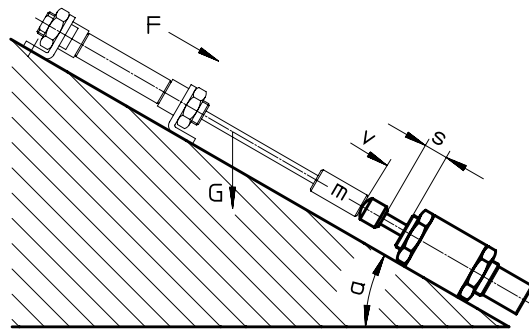

$$\begin{aligned}
 m &= 50 \text{ kg} \\
 v &= 1.5 \text{ m/s} \\
 \alpha &= 45^\circ \\
 F &= 190 \text{ N}
 \end{aligned}$$

( $\varnothing$  20 mm for  $p = 6$  bar,  
1800 strokes per hour)

When selecting the shock absorbers from the graphs (see data sheets), the curve immediately to the right of the point of intersection of the equivalent mass ( $m_{\text{equiv.}}$ ) and the impact velocity ( $v$ ) determines the force ( $A$ ). The curves move to the left as the additional force increases.

Three force curves are shown for each shock absorber. An average must be taken for intermediate values. As the graphs show shock absorbers DYSR-25-40 and YSR-25-40-C can be considered here.

It is yet to be determined whether the permissible cushioning work ( $W_{\text{max.}}$ ) and the cushioning work per hour ( $W_{\text{hmax.}}$ ) have been exceeded. The max. permissible values and the stroke length ( $s$ ) can be found in the tables (below the graphs).

Test:

$$\begin{aligned}
 W_{\text{total}} &= 1/2 \times m \times v^2 + A \times s \\
 &= (1/2 \times 50 \times 1.5^2 + \\
 &537 \times 0.04) \text{ Nm} = 78 \text{ J}
 \end{aligned}$$

$$\begin{aligned}
 W_{\text{h}} &= W_{\text{total}} \times \text{strokes/h} \\
 &= 78 \text{ Nm} \times 1\,800 \\
 &= 140\,000 \text{ J}
 \end{aligned}$$

Both shock absorbers are suitable for the above application.

Additional selection criteria include possibility of adjustment, and size.

| Result                 | DYSR-25-40                 | YSR-25-40-C                |
|------------------------|----------------------------|----------------------------|
| $W_{\text{total}}$     | 78 J                       | 78 J                       |
| $W_{\text{h}}$         | 140000 J                   | 140000 J                   |
| $W_{\text{max.}}^{1)}$ | 160 J > $W_{\text{total}}$ | 160 J > $W_{\text{total}}$ |
| $W_{\text{hmax.}}$     | 220000 > $W_{\text{max.}}$ | 150000 > $W_{\text{max.}}$ |

1) In both cases, utilisation is 49%.

## Data sheet

### Sizing example for rotary motion

Example for rotary motion:

$$m_{\text{equiv.}} = J/R^2 = 8 \text{ kg}$$

$$v = \omega \times R$$

$$A = M/R = 40 \text{ N}$$

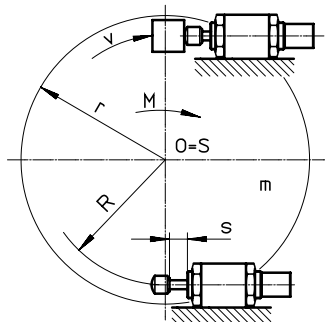

$$J = 2 \text{ kg m}^2$$

$$\omega = 4 \text{ rad/s}$$

$$R = 0.5 \text{ m}$$

$$M = 20 \text{ Nm}$$

900 strokes per hour

When selecting the shock absorbers from the graphs (see data sheets), the curve immediately to the right of the point of intersection of the equivalent mass ( $m_{\text{equiv.}}$ ) and the impact velocity ( $v$ ) determines the force ( $A$ ). The curves move to the left as the additional force increases. Three force curves are shown for each shock absorber. An average must be taken for intermediate values. As the graphs show, shock absorbers DYSR-16-20 and YSR-16-20-C are can be considered. It is yet to be determined whether the permissible cushioning work ( $W_{\text{max.}}$ ) and the cushioning work per hour ( $W_{\text{hmax.}}$ ) have been exceeded. The max. permissible values and the stroke length ( $s$ ) can be found in the tables (below the graphs). Comment: For rotary applications, the impact angle must be taken into account.

Test:

$$\begin{aligned} W_{\text{total}} &= 1/2 \times m \times v^2 + A \times s \\ &= (1/2 \times 8 \times 2^2 + \\ &40 \times 0.02) \text{ J} = 17 \text{ J} \end{aligned}$$

$$\begin{aligned} W_{\text{h}} &= W_{\text{total}} \times \text{strokes/h} \\ &= 17 \text{ J} \times 900 \\ &= 15\,300 \text{ J} \end{aligned}$$

Both shock absorbers are suitable for the above application. Additional selection criteria include possibility of adjustment, and size.

| Result             | DYSR-16-20 <sup>3)</sup>                | YSR-16-20-C                             |
|--------------------|---|---|
| $W_{\text{total}}$ | 17 J                                    | 17 J                                    |
| $W_{\text{h}}$     | 15 300 J                                | 15 300 J                                |
| $W_{\text{max.}}$  | 32 J > $W_{\text{total}}$ <sup>1)</sup> | 30 J > $W_{\text{total}}$ <sup>2)</sup> |
| $W_{\text{hmax.}}$ | 100000 > $W_{\text{max.}}$              | 64000 > $W_{\text{max.}}$               |

- 1) Utilisation is 53%.
- 2) Utilisation is 57%.
- 3) Operated without buffer.