

ELGA-BS

Spindle axis

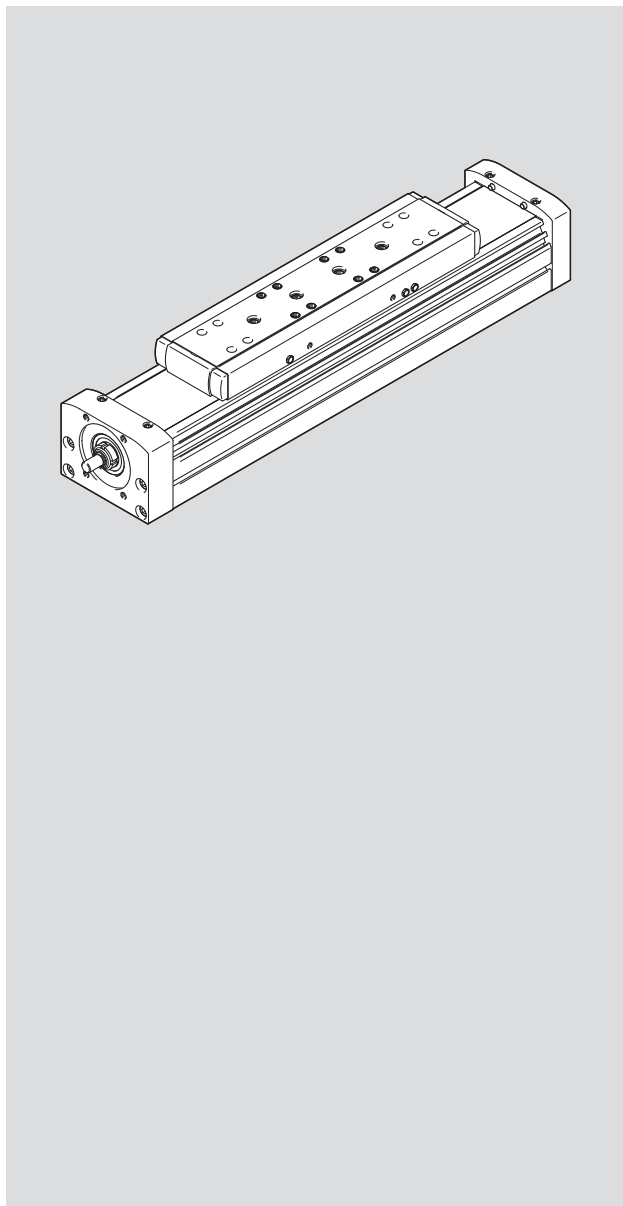

FESTO

Operating instruction



8127669

8127669
2023-05c
[8127671]

Translation of the original instructions

Table of contents

1	Applicable documents	4
2	Safety	4
	2.1 Safety instructions.....	4
	2.2 Intended use.....	4
	2.3 Training of qualified personnel.....	4
3	Additional information	4
4	Product overview	5
	4.1 Product design.....	5
	4.2 Function.....	5
5	Transport	6
6	Assembly	6
	6.1 Safety.....	6
	6.2 Mounting motor.....	6
	6.3 Mounting axis.....	7
	6.4 Mounting payload on the standard slide.....	8
	6.5 Mounting payload on the additional slide.....	9
	6.6 Mounting sensor.....	12
	6.7 Connecting sealing air.....	12
7	Commissioning	13
8	Maintenance	14
	8.1 Safety.....	14
	8.2 Checking reversing backlash.....	14
	8.3 Retensioning cover strip.....	14
	8.4 Cleaning axis.....	17
	8.5 Lubricating axis.....	17
9	Fault clearance	19
10	Technical data	21
	10.1 Technical data, mechanical.....	21
	10.2 Characteristic curves of support distances.....	23
	10.3 Characteristic speed curves.....	25

1 Applicable documents



All available documents for the product → www.festo.com/sp.

2 Safety

2.1 Safety instructions

- Observe the identifications on the product.
- Only use the product if it is in perfect technical condition.
- Before working on the product: Switch off the power supply, ensure that it is off and secure it against being switched on again.
- Store the product in a cool, dry environment protected from UV and corrosion. Keep storage times short.
- Store the product in ambient conditions without oils, greases and grease-dissolving vapours.

2.2 Intended use

The axis positions payloads or moves external guides.
The axis is approved for slide operation and yoke operation.



Fig. 1: Slide operation

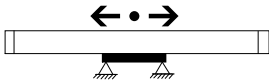

Fig. 2: Yoke mode

2.3 Training of qualified personnel

Work on the product may only be carried out by qualified personnel who can evaluate the work and detect dangers. The qualified personnel have knowledge and experience in handling electric drives and axes.

3 Additional information

- Contact the regional Festo contact if you have technical problems → www.festo.com.
- Accessories and spare parts → www.festo.com/catalogue.

4 Product overview

4.1 Product design

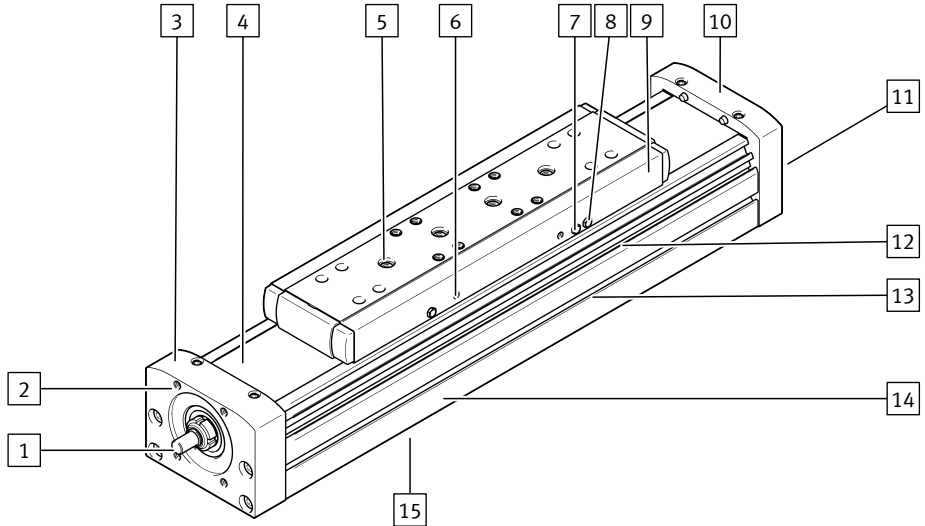

Fig. 3: Product design ELGA-BS

- | | |
|--|--|
| 1 Drive shaft | 9 Slide |
| 2 Thread for motor mounting kit | 10 End cap |
| 3 Drive cover | 11 Sealing air connection and threaded hole for foot mounting |
| 4 Cover strip | 12 Slot for sensors |
| 5 Threaded hole and centring hole for payload | 13 Slot for profile mounting, slot nut and sensor bracket |
| 6 Threaded hole for switch lug | 14 Profile |
| 7 Ball screw lubrication point | 15 Slot for slot nut |
| 8 Guide lubrication point | |

4.2 Function

The axis converts the rotary motion of the mounted motor to a linear motion of the slide. The drive screw converts the torque of the motor into a feed force. The linear motion of the slide is precisely guided by the guide. The integrated cover strip prevents abraded particles from access to the immediate vicinity of the drive. Sensors and displacement encoder enable query of end positions, reference position and intermediate position.

5 Transport

WARNING

Risk of injury due to falling product

If the product is lifted incorrectly, it may fall and cut, crush or separate body parts.

- Lift the product only with suitable load-bearing equipment.
-
- Store and transport the product in its original packaging. Observe the weight, the dimensions and the ambient conditions.
 - Take the centre of gravity of the product into consideration.
 - Store and transport the product in a horizontal position.
 - Comply with the maximum permitted support clearances when attaching transportation aids
 - ➔ 10.2 Characteristic curves of support distances. Compliance with the support clearances prevents the axis from excessive bending.

6 Assembly

6.1 Safety

WARNING

Risk of Injury due to Unexpected Movement of Components

For vertical or slanted mounting position: when power is off, moving parts can travel or fall uncontrolled into the lower end position.

- Bring moving parts of the product into a safe end position or secure them against falling.

Protection of the cover strip

The cover strip is equipped with a protective cover to prevent damage. This protective cover must be removed and disposed of before commissioning. After removing the protective cover, mechanical damage and contamination of the cover strip must be avoided.

6.2 Mounting motor

Observe the limit values for forces, torques and speeds if a non-recommended motor and motor mounting kit are used.

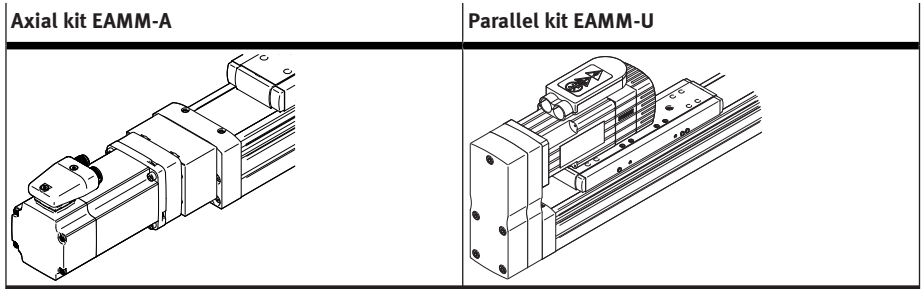

Tab. 1: Overview of mounting motors

- Mount the motor and motor mounting kit without tension.

6.3 Mounting axis

i

If high parallel torques are applied to the drive system at the same time, this will result in high mechanical loads at the mounting interfaces.

- Use the foot mounting HPE only in combination with the profile mounting MUE or the slot nuts NST.

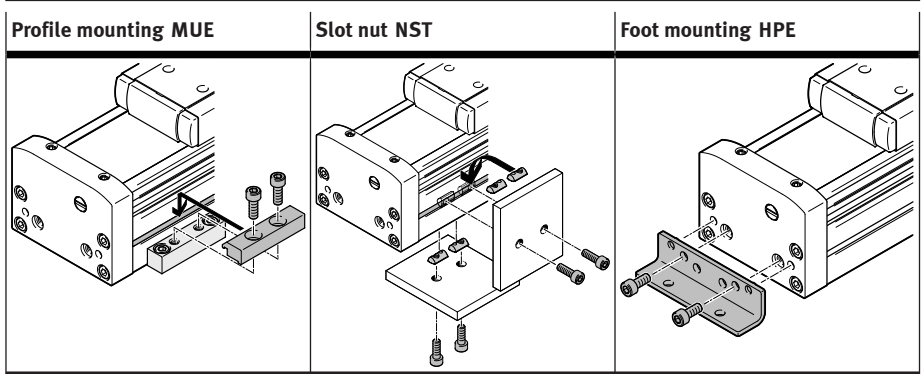

Tab. 2: Overview of mounting components

Requirements:

- Adequate clearance for payload to avoid collisions with motor, mounting components and sensor components.
- Sufficient space for maintenance work.
- Flatness of the mounting surface of 0.05% of the stroke length or maximum 0.5 mm over the stroke length of the bearing surface.
- Required support points lie within the specified support clearances → 10.2 Characteristic curves of support distances. Compliance with the support clearances prevents the axis from excessive bending.

1. Place the mounting components on the support points.

2. Tighten the screws. Observe the maximum tightening torque and maximum screw-in depth.



When used in multi-axis systems: align to the first axis and install without tension.

ELGA-BS-...	-70	-80	-120	-150
Profile mounting MUE				
Thread	Instruction manual → www.festo.com/sp .			
Slot nut mounting NST				
Thread	M5	M5	M6	M6
Max. screw-in depth t_{max} [mm]	6	6	12	12
Foot mounting HPE				
Thread	M5	M5	M8	M8
Max. tightening torque [Nm]	5.9	5.9	24	24
Max. screw-in depth t_{max} [mm]	10	10	16	18

6.4 Mounting payload on the standard slide

WARNING

Unexpected movement of components.

Injury due to impacts or crushing.

- Before working on the product, switch off the control and secure it to prevent it from being switched back on accidentally.

WARNING

Risk of Injury due to Unexpected Movement of Components

For vertical or slanted mounting position: when power is off, moving parts can travel or fall uncontrolled into the lower end position.

- Bring moving parts of the product into a safe end position or secure them against falling.

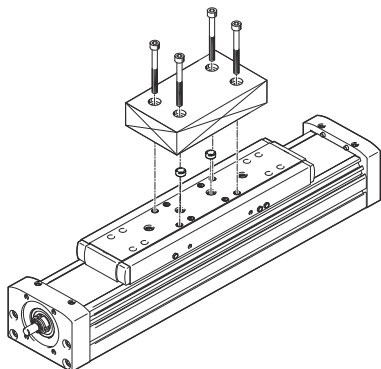

Fig. 4: Mounting payload, example "top mounting"

Requirements:

- Adequate clearance for payload to avoid collisions with motor, mounting components and sensor components.
 - Sufficient space for maintenance work.
 - A payload mounting surface flatness of 0.01 mm above the slide surface.
 - Minimise the guide load. Short lever arms from the guide centre to the force application points and centres of gravity of the payload.
1. Place centring components in the centring holes.
 2. Position the payload at the intended location.
 3. Tighten the screws. Observe the maximum tightening torque and maximum screw-in depth.

ELGA-BS-...	-70		-80		-120		-150	
Direct fastening								
Thread	M5	M6	M5	M6	M5	M6	M6	M8
Max. tightening torque [Nm]	5.9	9.9	5.9	9.9	5.9	9.9	9.9	24
Max. screw-in depth t_{max} [mm]	7.5		9	9.7	9.7	12.6	10.7	14
Centring pins [mm]	∅ 5 H7	-						
Centring sleeve [mm]	∅ 9 H7							

6.5 Mounting payload on the additional slide

⚠ WARNING

Unexpected movement of components.

Injury due to impacts or crushing.

- Before working on the product, switch off the control and secure it to prevent it from being switched back on accidentally.

⚠ WARNING

Risk of Injury due to Unexpected Movement of Components

For vertical or slanted mounting position: when power is off, moving parts can travel or fall uncontrolled into the lower end position.

- Bring moving parts of the product into a safe end position or secure them against falling.

i

- When using an additional external guide, ensure that the axes and guide are precisely parallel and aligned.
- Recommendation: use guide mountings with tolerance compensation.

Tension due to manufacturing tolerances may be encountered with axes with additional slides when mounting an adapter plate supplied by the customer.

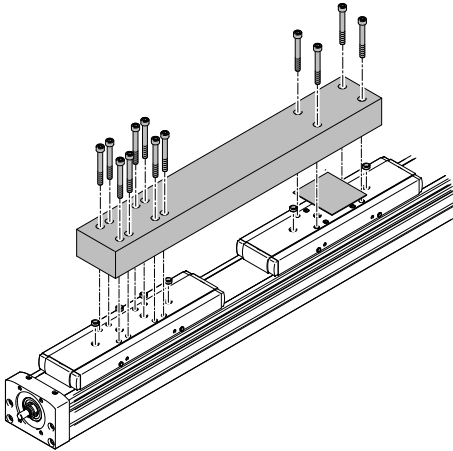

Fig. 5: Mounting payload, example "top mounting"

Requirements:

- A fixed-floating bearing for the carriage connection.
- Use a tolerance compensation in case of height deviation from the standard slide surface.
- Adequate clearance for payload to avoid collisions with motor, mounting components and sensor components.
- Sufficient space for maintenance work.
- A payload mounting surface flatness of 0.01 mm above the slide surfaces.
- Minimise the guide load. Short lever arms from the guide centre to the force application points and centres of gravity of the payload.

1. Place centring components in the centring holes.
2. Mount the adapter plate on the standard slide.
3. Place the tolerance compensation elements on the additional slide.
4. Align and mount the adapter plate on the additional slide.

Assembly

5. Tighten the screws. Observe the maximum tightening torque and maximum screw-in depth.

ELGA-BS-KF-...-Z...	-70		-80		-120		-150	
Direct fastening								
Thread	M5	M6	M5	M6	M5	M6	M6	M8
Max. tightening torque [Nm]	5.9	9.9	5.9	9.9	5.9	9.9	9.9	24
Max. screw-in depth t_{\max} [mm]	7.5		9	9.7	9.7	12.6	10.7	14
Centring pins [mm]	∅ 5 H7	-						
Centring sleeve [mm]	∅ 9 H7							

6. Check the running behaviour of the slides.

6.6 Mounting sensor

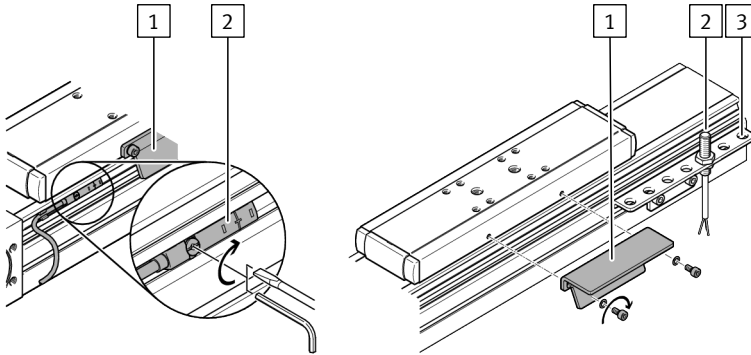

Fig. 6: Mounting switch lug, sensor and sensor bracket

- | | | | |
|---|------------|---|----------------|
| 1 | Switch lug | 3 | Sensor bracket |
| 2 | Sensor | | |

Requirements:

- Protect the sensor from external magnetic or ferritic influences with min. 10 mm distance from slot nuts.
- Use a hardware limit switch with N/C contact function to guarantee protection in the event of a sensor failure.
- Use an inductive sensor.
- The measuring system is mounted.
- Mounting is only possible on the side without measuring system for axes with measuring system ELGA-...-M1/-M2.

1. Mount the switch lug.
2. If necessary, mount the sensor bracket.
3. Mount the sensor.
4. If necessary, mount the cable with clips.
5. If necessary, mount the slot cover.

6.7 Connecting sealing air

The use of sealing air at approx. ± 0.02 MPa (± 0.2 bar, ± 2.9 psi) reduces or prevents the following forms of contamination:

- The application of negative pressure minimises the release of abraded particles into the environment.
- The application of overpressure reduces the penetration of dirt into the drive train.

1. Remove the sealing air plug screw from the threaded hole.

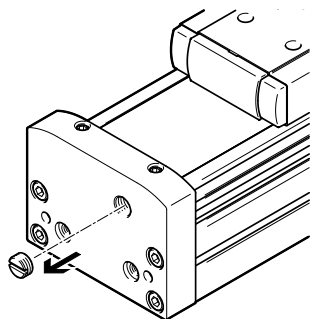

2. Mount the fitting and connect the hose.

7 Commissioning

⚠ WARNING

Risk of injury due to unexpected movement of components.

- Protect the positioning range from unwanted intervention.
- Keep foreign objects out of the positioning range.
- Perform commissioning with low dynamic response.

i

Block-shaped acceleration profiles without jerk limitation can have the following effects:

- High mechanical loads on the lead screw due to high force peaks.
- Overshooting effects during positioning.
- Rise of the entire system.

Recommendation: reduce high force peaks in the acceleration and deceleration phases by using the jerk limitation.

i

Identical axes can generate different running noises depending on the parameterisation, mode of operation, type of mounting, installation environment and components.

Requirements:

- The motor encoder is referenced to the reference mark by a homing run.
- The motor encoder has the absolute reference to the reference mark.
- The direction of movement of the slide is determined by the direction of rotation of the motor.
- The mounting of the drive system has been checked.
- The protective cover of the cover strip is removed.
- The installation on the motor has been checked.
- There are no foreign objects in the movement space of the drive system.
- Maximum permissible feed force and drive torque as a function of acceleration, deceleration, e.g. with stop function or quick stop, speed, moving mass and mounting position, are not exceeded.

- Axis is not mechanically overloaded and dynamic setpoint deviation is not exceeded as a result of force peaks, torque peaks or overshoot effects, e.g. overrunning the end position.
Overloads and overruns as a result of jerk limitation must be restricted by reduced acceleration and deceleration setpoints or optimised controller settings.
 - The software end positions are not within the effective range of the mechanical stops.
 - No homing or test run to mechanical end stops.
1. Start check run.
 2. Select permissible reference points "against reference switch" for the homing.
 3. Start the homing run with reduced speed setpoints, acceleration setpoints and deceleration setpoints.
 4. Start the test run with reduced speed setpoints, acceleration setpoints and deceleration setpoints.
 5. Check that the slide completes the entire travel cycle within the specified time.
 - ↳ The slide stops its travel when it reaches a limit switch and the drive system is ready for operation.

8 Maintenance

8.1 Safety

⚠ WARNING

Unexpected movement of components.

Injury due to impacts or crushing.

- Before working on the product, switch off the control and secure it to prevent it from being switched back on accidentally.

8.2 Checking reversing backlash

- Check the reversing backlash (reversal error) of the slide at every maintenance interval, e.g. lubrication interval. If the maximum permissible reversing backlash is exceeded, replace the axis.

ELGA-BS-...	70	80	120	150
Max. permissible reversing backlash [mm]	0.1		0.2	

8.3 Retensioning cover strip

1. Check the cover strip for wave formation every 2000 km.
2. Retension the cover strip as follows if waves are detected.
3. Replace the belt reversals and the cover strip if retension is no longer possible.

Retensioning cover strip on both sides for the standard reversal ELGA-...

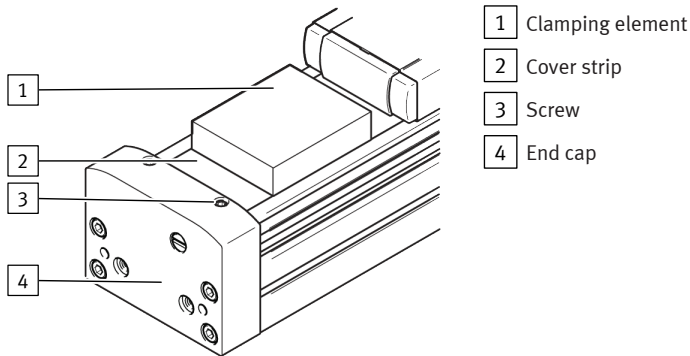
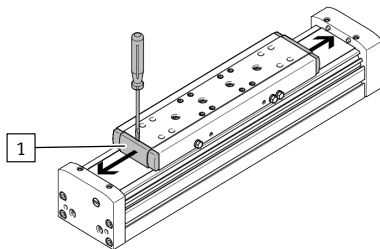

Fig. 7: Retensioning cover strip

1. Unscrew the screws **3**.
2. Push the cover strip **2** into the cover **4**.
3. Tighten the cover strip with a clamping element **1**.
4. Tighten the screws to 2 Nm.

Retensioning cover strip for magnetic reversal ELGA-...-P11

1. Lever the clips **1** off both sides of the covers with a screwdriver.



2. Remove the screws **2** on both sides of the covers **3**.
Remove the covers from both sides of the slide.

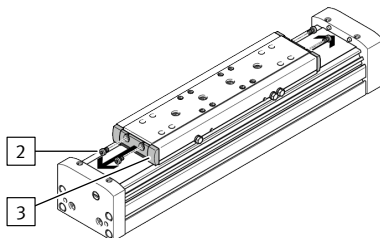

3. Check the cover strip for wave formation.
 - If the cover strip contacts the surface of the slide or if there is wave formation, retension the cover strip → Step 4.
 - Install the removed slide components without contact with cover strip and no wave formation → Step 7.

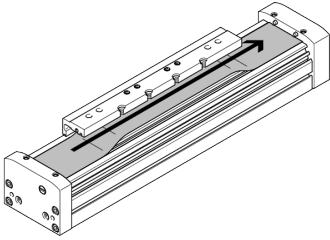

4. Unscrew clamping screws **4** on one side.

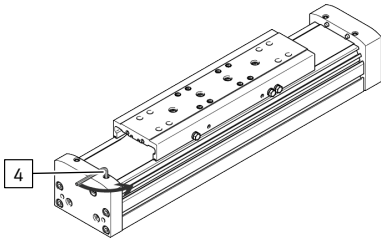

5. Slowly press the cover strip flat onto the guide surfaces in the direction of the loosened clamping screws **5**.

Tighten the clamping screws **4** to 2 Nm while maintaining the tension of the cover strip.

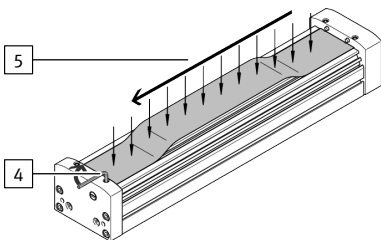

Maintenance

- Place the covers **3** on the slide on both sides. The cover strip must not contact the cover. Tighten the screws **2** to 1.2 Nm for sizes 70 and 80 and to 2 Nm for sizes 120 and 150.

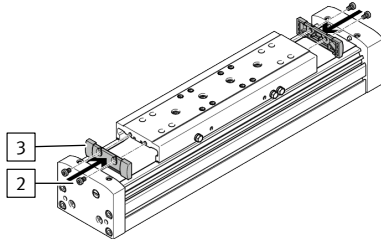

- Place the clips **1** on the covers on both sides and press until they click into place.

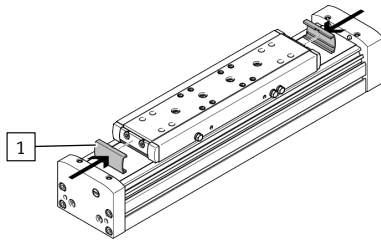

8.4 Cleaning axis

Clean the product with a clean, soft cloth and non-abrasive cleaning agents.

8.5 Lubricating axis

Requirements:

- The pressure grease gun LUB-1, 647958 is available.
 - The roller bearing grease LUB-KC1, 684474 is available.
 - The lubrication adapter LUB-1-TR-I, 647959 or LUB-1-TR-L, 647960 is available.
- Calculate the load comparison factor f_v with formula for combined loads → 10.1 Technical data, mechanical.
 - Take the lubrication interval S_{int} as a function of the load comparison factor f_v from the characteristic curve.

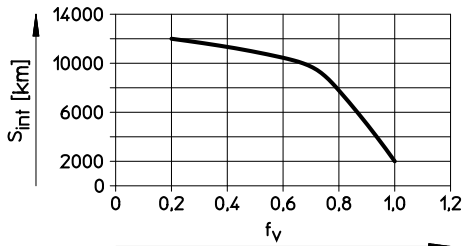

3. Determine the load factors:
 - Dusty and dirty environment.
 - Nominal stroke < 300 mm or > 2000 mm.
 - Ambient temperature > +40 °C.
 - Operating age > 3 years.
 - The travel profile matches triangular operation, e.g. frequent acceleration and braking.
4. If there is a load factor, halve the lubrication interval S_{int} . If there are multiple load factors, reduce the lubrication interval S_{int} to a quarter of the standard interval.
5. If necessary, replace the needle point of the pressure grease gun with the lubrication adapter, axial outlet or radial outlet.
6. Press the pressure grease gun onto the lubrication nipple for the ball screw. Press in the roller bearing grease at the front right.

ELGA-BS-...	-70	-80	-120	-150
Grease volume per lubricating hole [g]	2	2.5	3	15

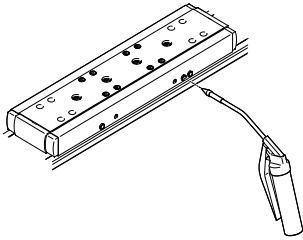

7. Press the pressure grease gun on the lubricating hole for the recirculating ball bearing guide. Inject the roller bearing grease at the front left and right.

ELGA-BS-...	-70	-80	-120	-150
Grease volume per lubricating hole [g]	0.45	0.8	2	3.4

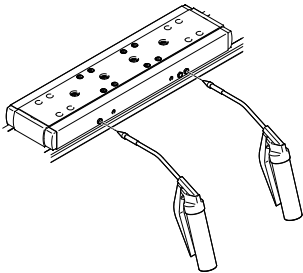

8. Move along the complete travel distance during the lubrication process to distribute the grease evenly in the interior.

9. If necessary, grease other components with roller bearing grease, e.g. the guide rail.

9 Fault clearance

WARNING

Unexpected movement of components.

Injury due to impacts or crushing.

- Before working on the product, switch off the control and secure it to prevent it from being switched back on accidentally.

WARNING

Risk of injury due to unexpected movement of components.

- Protect the positioning range from unwanted intervention.
- Keep foreign objects out of the positioning range.
- Perform commissioning with low dynamic response.

Malfunction	Cause	Remedy
Loud running noises, vibrations or rough running of the axis.	Coupling distance too short.	– Observe the permissible coupling spacings → Assembly instructions of the motor mounting kit.
	Torsional stresses	– Install axis without tension. Make sure that the contact surface is flat → 6.3 Mounting axis. – Change the arrangement of the payload. – Align axes parallel to each another.
	Current controller settings.	– Optimise controller data, e.g. speed, acceleration,
	Resonance oscillation of the axis.	– Change travel speed.
	Wear on bearing or guide.	– Contact local Festo Service. – Replace axis.
	Wear of the ball screw drive.	– Check reversing backlash → 8.2 Checking reversing backlash. – Contact local Festo Service. – Replace axis.

Malfunction	Cause	Remedy
Loud running noises, vibrations or rough running of the axis.	Insufficient lubrication of the guide.	<ul style="list-style-type: none"> - Lubricate the guide → 8.5 Lubricating axis.
Vibrations on the slide.	Operation at the resonant frequency of the axis.	<ul style="list-style-type: none"> - Change travel speed. - Change the acceleration. - Increase axis stiffness, e.g. shorter support distances. - Change the payload geometry.
Long oscillations of the profile.	Resonant frequency of profile and payload too low.	<ul style="list-style-type: none"> - Increase axis stiffness, e.g. shorter support distances. - Change the payload geometry.
Slide does not move.	Coupling slips.	<ul style="list-style-type: none"> - Check the mounting of the shaft-hub connection → Assembly instructions of the motor mounting kit.
	Loads are too high.	<ul style="list-style-type: none"> - Reduce forces and torques. Consider dynamics.
	Screws too long for mounting payload.	<ul style="list-style-type: none"> - Observe the screw-in depth → 6.4 Mounting payload on the standard slide.
	Ball screw drive blocked.	<ul style="list-style-type: none"> - Contact local Festo Service. - Replace axis.
Overruns the end position.	Sensor does not switch.	<ul style="list-style-type: none"> - Check sensor, installation and parameterisation.
Idling torque too high.	Wear in the drivetrain.	<ul style="list-style-type: none"> - Contact local Festo Service. - Replace axis.
Wave formation on the cover strip or aluminium abrasion on the axis.	Wear on belt reversals.	<ul style="list-style-type: none"> - Retension cover strip → 8.2 Checking reversing backlash. - Replace belt reversal and cover strip.

Tab. 3: Fault clearance

10 Technical data

10.1 Technical data, mechanical

ELGA-BS-...	-70-...-10P	-80-...-10P	-80-...-20P
Design	Electromechanical axis with ball screw		
Guide	Recirculating ball bearing guide		
Mounting position	Any		
Max. feed force [N]	650	1600	1600
Max. idling torque at max. speed [Nm]	0.45	0.75	0.75
Max. rotational speed [rpm]	3000	3000	3000
Max. speed [m/s]	0.5	0.5	1
Max. acceleration [m/s ²]	15		
Repetition accuracy [mm]	± 0.02		
Feed constant [mm/rev]	10	10	20
Ambient temperature [°C]	-10 ... +60		
Degree of protection	IP40		
Max. permissible lateral force [N] on the drive shaft	220	250	250
Max. permissible forces and torques on the slide			
F _y [N]	1500	2500	2500
F _z [N]	1850	3050	3050
M _x [Nm]	16	36	36
M _y [Nm]	132	228	228
M _z [Nm]	132	228	228
Calculating the load comparison factor			

ELGA-BS-...	-70-...-10P	-80-...-10P	-80-...-20P
f_v	$f_v = \frac{ F_y, dyn }{F_{y, max}} + \frac{ F_z, dyn }{F_{z, max}} + \frac{ M_x, dyn }{M_{x, max}} + \frac{ M_y, dyn }{M_{y, max}} + \frac{ M_z, dyn }{M_{z, max}} \leq 1$		
	<p>The diagram shows a 3D perspective view of the ELGA-BS axis assembly. It features a motor on the left, a ball screw, and a sliding carriage. Six force and moment vectors are indicated: F_x (axial force), F_y (lateral force), F_z (vertical force), M_x (axial torque), M_y (lateral torque), and M_z (vertical torque).</p>		

Tab. 4: Technical data, mechanical

ELGA-BS-...	-120-...-10P	-120-...-25P	-150-...-40P
Design	Electromechanical axis with ball screw		
Guide	Recirculating ball bearing guide		
Mounting position	Any		
Max. feed force [N]	3400	3400	6400
Max. idling torque at max. speed [Nm]	2.25	2.25	6.5
Max. rotational speed [rpm]	3600	3600	3000
Max. speed [m/s]	0.6	1.5	2
Max. acceleration [m/s ²]	15		
Repetition accuracy [mm]	± 0.02		
Feed constant [mm/rev]	10	25	40
Ambient temperature [°C]	-10 ... +60		
Degree of protection	IP40		
Max. permissible lateral force [N] on the drive shaft	500	500	4000
Max. permissible forces and torques on the slide			
F_y [N]	5500	5500	5500
F_z [N]	6890	6890	11000
M_x [Nm]	104	104	167
M_y [Nm]	680	680	1150

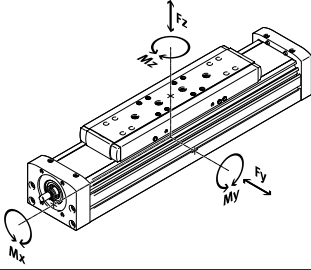
ELGA-BS-...		-120-...-10P	-120-...-25P	-150-...-40P
Mz	[Nm]	680	680	1150
Calculating the load comparison factor				
f _v	$f_v = \frac{ F_y, dyn }{F_y, max} + \frac{ F_z, dyn }{F_z, max} + \frac{ M_x, dyn }{M_x, max} + \frac{ M_y, dyn }{M_y, max} + \frac{ M_z, dyn }{M_z, max} \leq 1$			
				

Tab. 5: Technical data, mechanical

10.2 Characteristic curves of support distances

The maximum permissible support distance L without profile mounting MUE/central support EAHF as a function of force F_y/F_z with a maximum deflection of 0.5 mm.

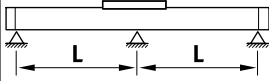
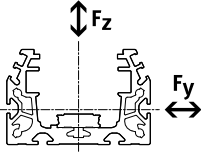
Support distance	Force load
	

Tab. 6: Overview of support distance and force load

Technical data

ELGA-BS-KF-70/80/120/150

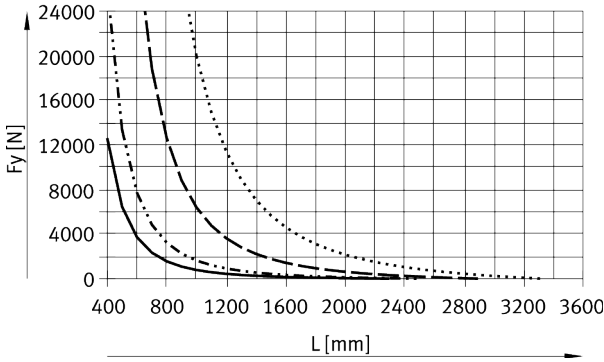

- ELGA-BS-KF-70
- - - ELGA-BS-KF-80
- - - ELGA-BS-KF-120
- ELGA-BS-KF-150

Fig. 8: The support distance L as a function of force Fy

ELGA-BS-KF-70/80/120/150

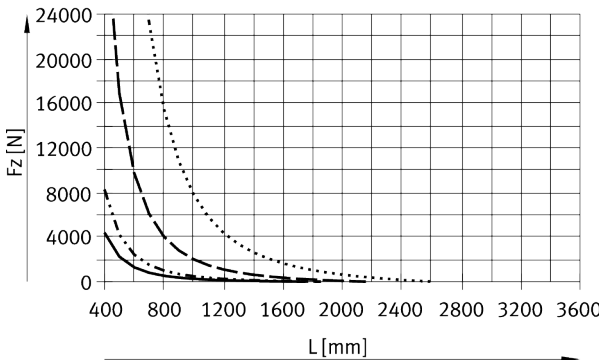

- ELGA-BS-KF-70
- - - ELGA-BS-KF-80
- - - ELGA-BS-KF-120
- ELGA-BS-KF-150

Fig. 9: The support distance L as a function of force Fz

10.3 Characteristic speed curves

Speed v as a function of rotational speed n .



Rotational speed n and speed v are stroke-dependent. Observe the maximum permissible speed v as a function of working stroke l .

ELGA-BS-KF-...

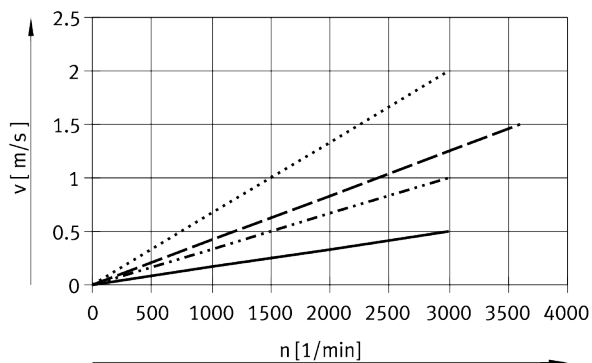

- ELGA-BS-KF-70-...-10P/-80-...-10P/-120-...-10P
- · - · ELGA-BS-KF-80-...-20P
- - - ELGA-BS-KF-120-...-25P
- ELGA-BS-KF-150-...-40P

Fig. 10: Speed v as a function of rotational speed n

Speed v as a function of working stroke l .

Technical data

ELGA-BS-KF-70

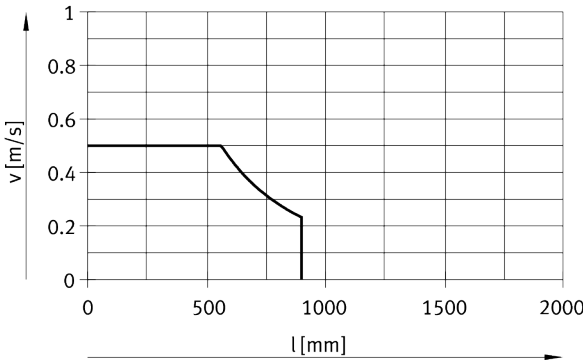

— ELGA-BS-KF-70-...-10P

Fig. 11: ELGA-BS-KF-70, speed v as a function of working stroke l

ELGA-BS-KF-80

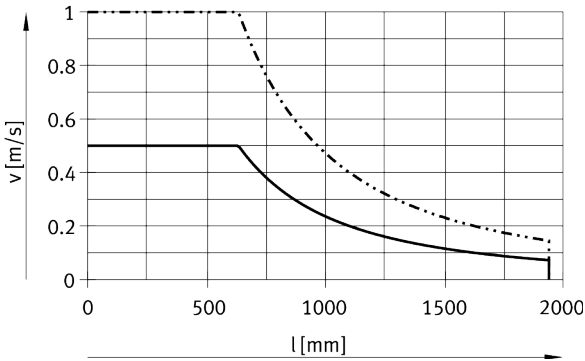

— ELGA-BS-KF-80-...-10P

- · - ELGA-BS-KF-80-...-20P

Fig. 12: ELGA-BS-KF-80, speed v as a function of working stroke l

Technical data

ELGA-BS-KF-120

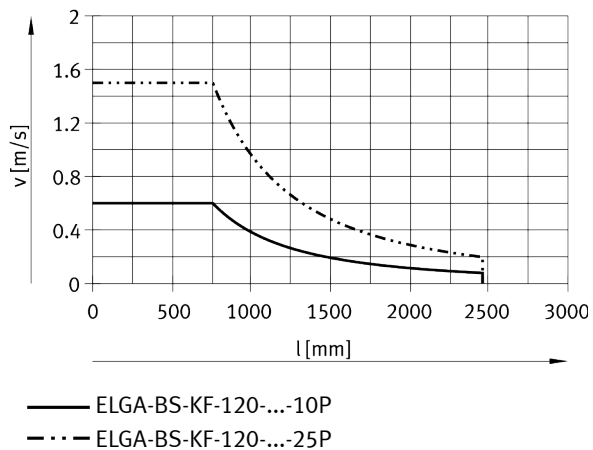

Fig. 13: ELGA-BS-KF-120, speed v as a function of working stroke l

ELGA-BS-KF-150

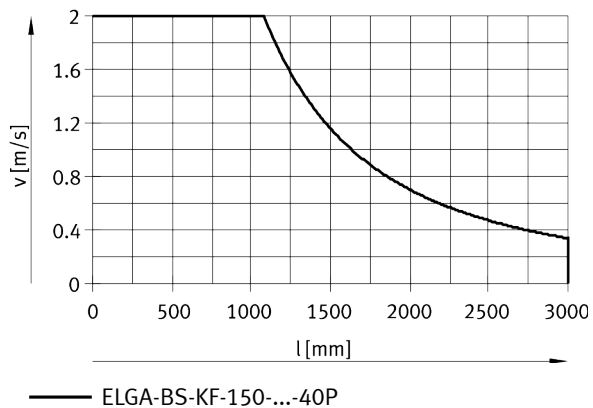

Fig. 14: ELGA-BS-KF-150, speed v as a function of working stroke l

Copyright:
Festo SE & Co. KG
Ruiter Straße 82
73734 Esslingen
Germany

Phone:
+49 711 347-0

Internet:
www.festo.com