

Air guns

FESTO



Low consumption air guns LSP-1/4-D

Technical data

FESTO

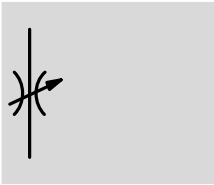

 Operating pressure
0 ... 10 bar



- Precise, infinitely variable, lever operated flow metering
- Sturdy aluminium design
- Interchangeable nozzles

General technical data	
Exhaust function	Metered blowing
Pneumatic connection	Female thread G $\frac{1}{4}$
Operating medium	Compressed air in accordance with ISO 8573-1:2010 [7:--:-]
Note on operating/pilot medium	Operation with lubricated medium possible (in which case lubricated operation will always be required)
Operating pressure [bar]	0 ... 10
Standard nominal flow rate [l/min]	120 at 6 bar
Noise level [dB (A)]	90 at 6 bar
Ambient temperature [°C]	-10 ... +50
Weight [g]	240

• Note: This product conforms to ISO 1179-1 and to ISO 228-1

Materials	
Housing	Wrought aluminium alloy
Note on materials	RoHS-compliant

Dimensions

[Download CAD data → www.festo.com](http://www.festo.com)

 Note
This air gun has no pressure regulating valve.

 Note
Compressed air guns must not be pointed at people.

1 Sealing surface

D1	D2	D3	H1	H2	H3	L1	C1	C2
G $\frac{1}{4}$	1.5	18.5	141	95	0.3	101	14	17

• Note: This product conforms to ISO 1179-1 and to ISO 228-1

Ordering data		
Pneumatic connection	Part No.	Type
G $\frac{1}{4}$	35528	LSP-1/4-D

Low consumption air guns LSP-1/4-C

Technical data

- Precise, infinitely variable, lever operated flow metering
- Interchangeable nozzles

 Operating pressure
0 ... 10 bar





General technical data	
Exhaust function	Metered blowing
Pneumatic connection	Female thread G $\frac{1}{4}$
Operating pressure [bar]	0 ... 10
Operating medium	Compressed air in accordance with ISO 8573-1:2010 [7:--:-]
Note on operating/pilot medium	Operation with lubricated medium possible (in which case lubricated operation will always be required)
Standard nominal flow rate [l/min]	120 at 6 bar
Noise level [dB (A)]	90 at 6 bar
Ambient temperature [°C]	-10 ... +50
Weight [g]	125

-||- Note: This product conforms to ISO 1179-1 and to ISO 228-1

Materials	
Housing	Reinforced polyamide

Dimensions Download CAD data → www.festo.com

 Note
This air gun has no pressure regulating valve.

 Note
Compressed air guns must not be pointed at people.

D1	D2	H1	H2	L1	L2	$\varnothing C1$
G $\frac{1}{4}$	1.5	112	96.2	154.4	80	14

-||- Note: This product conforms to ISO 1179-1 and to ISO 228-1

Ordering data		
Pneumatic connection	Part No.	Type
G $\frac{1}{4}$	184318	LSP-1/4-C

Air guns

Accessories

FESTO

Air gun nozzle LPZ-SD with safety shield

- Accurate, high power air jet with protective air shield for chips and dust
- Low noise level

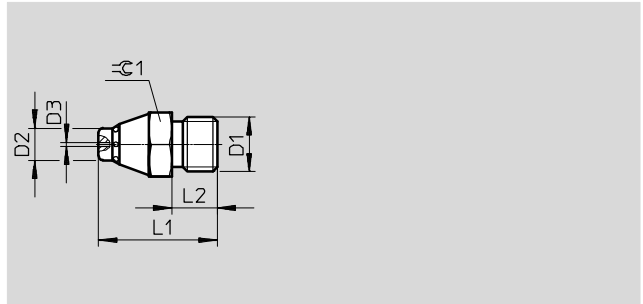

Operating and environmental conditions		
Ambient temperature	[°C]	-10 ... +50
Noise level	[dB(A)]	80

Materials	
Air gun nozzle	Aluminium
Note on materials	RoHS-compliant

Dimensions and ordering data						
Pneumatic connection	D2	D3	L1	L2	±0.1	Part No. Type
D1	∅	∅				
Male thread M12x1.25	7	0.8	26	10	14	184321 LPZ-SD

Air gun nozzle LPZ-LD with noise reduction

- Powerful, focused air jet
- For blowing out, drying and cooling large surfaces
- Low noise level

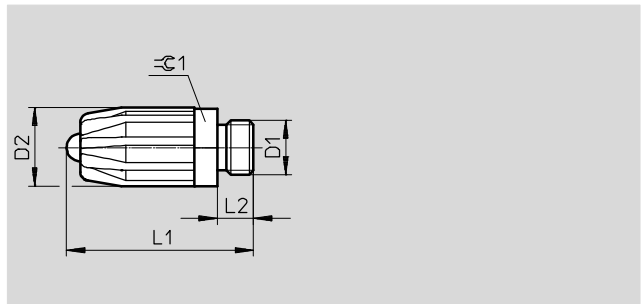

Operating and environmental conditions		
Ambient temperature	[°C]	-10 ... +50

Materials	
Air gun nozzle	Chrome plated die-cast zinc, aluminium
Note on materials	RoHS-compliant

Dimensions and ordering data						
Pneumatic connection	D2	L1	L2	±0.1	Part No. Type	
D1	∅					
Male thread M12x1.25	17.6	41	8	17	184322 LPZ-LD	

Air guns

Accessories

FESTO

Air gun nozzle LPZ-RG-150-B with straight tube

- Accurate, high power air jet for difficult to access locations

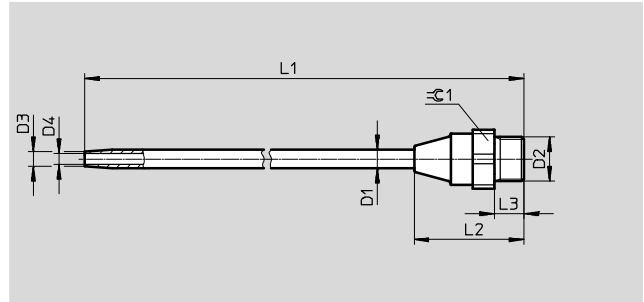
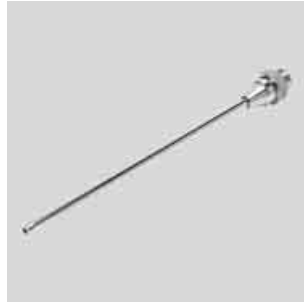

Operating and environmental conditions

Ambient temperature	[°C]	-10 ... +50
Noise level	[dB(A)]	90

Materials

Air gun nozzle	Nickel-plated brass
Note on materials	RoHS-compliant

Dimensions and ordering data

Pneumatic connection	D1	D3	D4	L1	L2	L3	$\varnothing 1$	Part No.	Type
D2	\varnothing	\varnothing	\varnothing						
Male thread M12x1.25	5	4	3	173	30	8	17	565317	LPZ-RG-150-B

Air gun nozzle LPZ-RB-150-B with elbow tube

- Accurate, high power air jet for difficult to access locations
- 360° rotatable

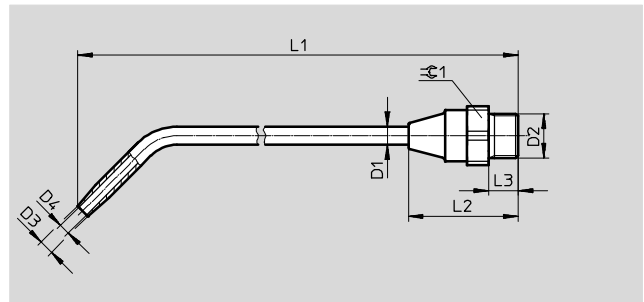

Operating and environmental conditions

Ambient temperature	[°C]	-10 ... +50
Noise level	[dB(A)]	90

Materials

Air gun nozzle	Nickel-plated brass
Note on materials	RoHS-compliant

Dimensions and ordering data

Pneumatic connection	D1	D3	D4	L1	L2	L3	$\varnothing 1$	Part No.	Type
D2	\varnothing	\varnothing	\varnothing						
Male thread M12x1.25	5	4	3	168	30	8	17	565316	LPZ-RB-150-B

Nominal flow rate q_n with fully actuated lever as a function of the output pressure p
measured using low consumption air gun LSP- $\frac{1}{4}$ -C

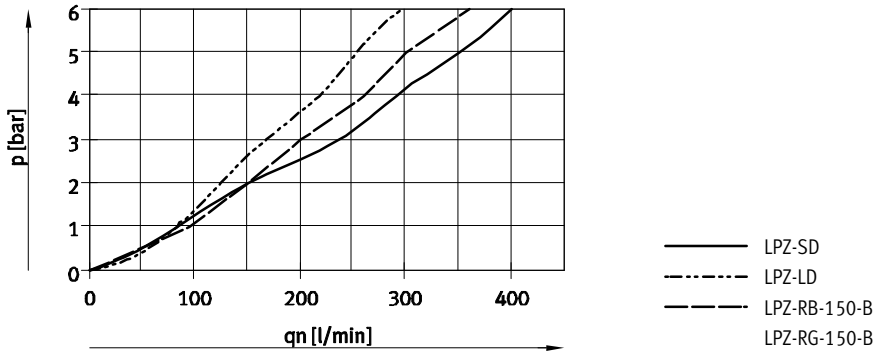

Festo - Your Partner in Automation



1 Festo Inc.
5300 Explorer Drive
Mississauga, ON L4W 5G4
Canada

Festo Customer Interaction Center
Tel: 1 877 463 3786
Fax: 1 877 393 3786
Email: customer.service.ca@festo.com



2 Festo Pneumatic
Av. Ceylán 3,
Col. Tequesquináhuac
54020 Tlalnepantla,
Estado de México

Multinational Contact Center
01 800 337 8669
ventas.mexico@festo.com



3 Festo Corporation
1377 Motor Parkway
Suite 310
Islandia, NY 11749

Festo Customer Interaction Center
1 800 993 3786
1 800 963 3786
customer.service.us@festo.com



4 Regional Service Center
7777 Columbia Road
Mason, OH 45040

Connect with us



www.festo.com/socialmedia



www.festo.com

Subject to change